

# SIDEROAD AND ENTRANCE DETAILS

## EX. HMA OR PCC SIDEROADS WITH BUTT JOINT

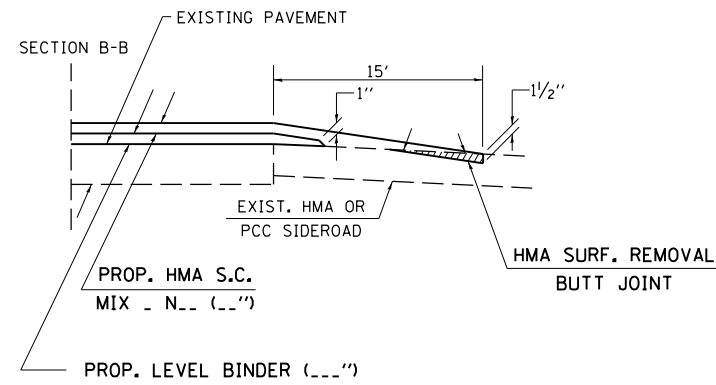

## AGG. PRIVATE OR COMMERCIAL ENTRANCE

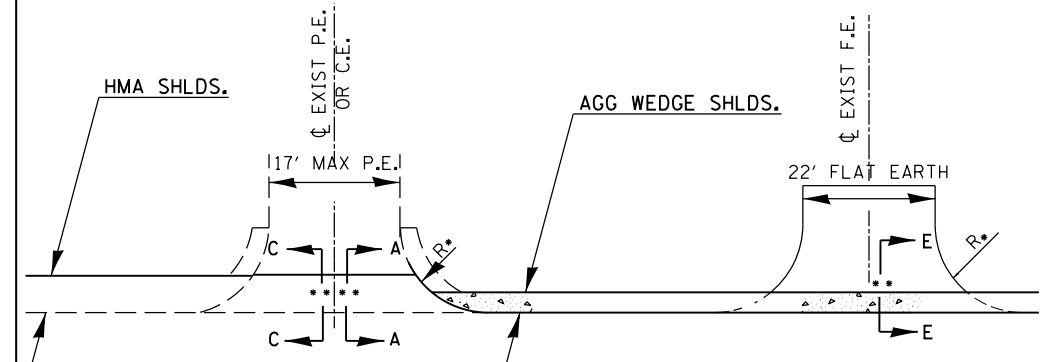
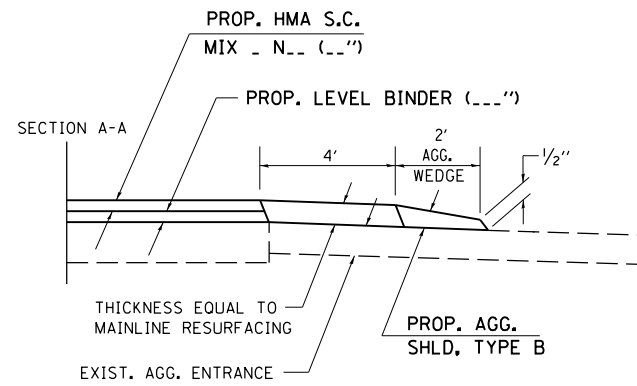

## EX. AGGREGATE SIDEROAD

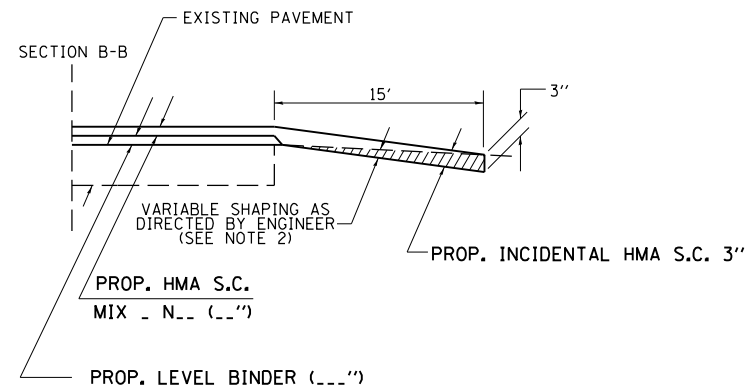

## HMA, PCC, OR OIL & CHIP PRIVATE OR COMMERCIAL ENTRANCE

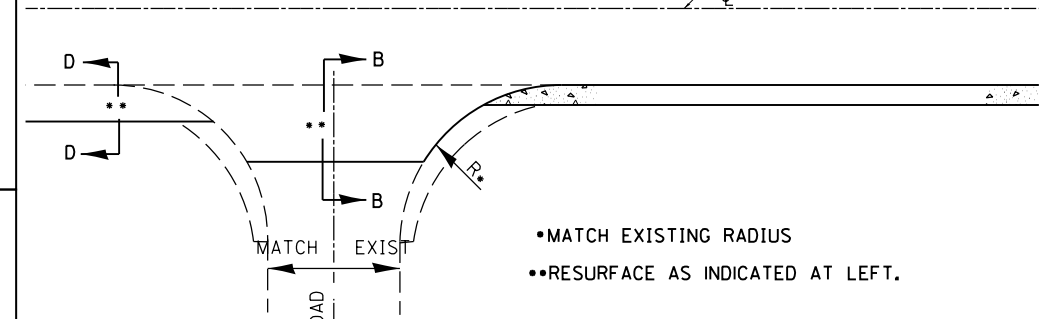
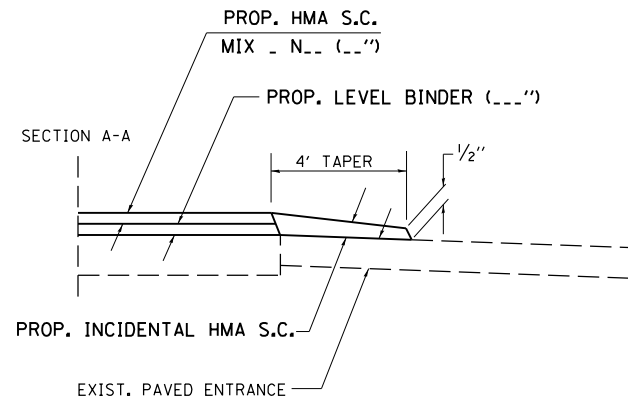

- MATCH EXISTING RADIUS
- RESURFACE AS INDICATED AT LEFT.

### ENTRANCE SCHEDULE

TYPE	NUMBER OF ENTRANCES
P.E.	40
C.E.	25

## EX. OIL & CHIP SIDEROAD

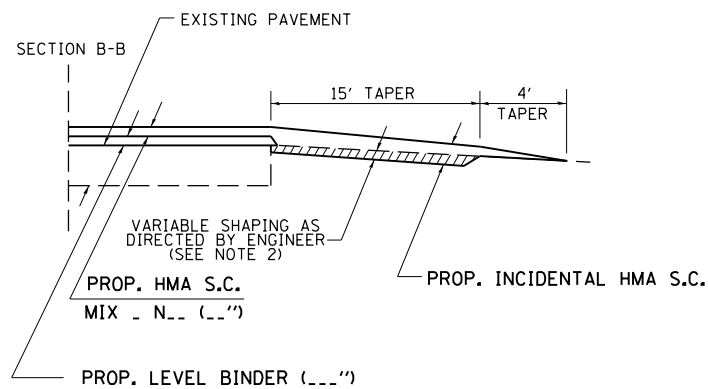

### NOTES

1. IF EXISTING SUBBASE IS INADEQUATE, AS DETERMINED BY THE ENGINEER, THE SIDE ROADS SHALL BE CORED OUT AND AGGREGATE SUBBASE, TYPE B SHALL BE PLACED FOR BASE. THE COST OF CORING OUT THE SIDE ROAD AND ANY AGGREGATE BASE COURSE SHALL BE PAID FOR AS SPECIFIED IN ART. 109.04 OF THE STANDARD SPECIFICATIONS FOR ROAD AND BRIDGE CONSTRUCTION. IF EXISTING SUBBASE IS DETERMINED TO BE ADEQUATE, THE PREPARATION OF THE BASE SHALL BE CONSTRUCTED ACCORDING TO ARTICLE 406.09.
2. VARIABLE SHAPING IS INCLUDED IN THE COST OF INCIDENTAL HOT-MIX ASPHALT SURFACE.

FILE NAME =	USER NAME = \$USER\$	DESIGNED -	REVISED -
et:\pw\work\p\dot\h\olleyb1\0269923\7821	h-sht-plan.dgn	DRAWN -	REVISED -
	PLOT SCALE = 100.0000' / 1"	CHECKED -	REVISED -
	PLOT DATE = 3/20/2014	DATE -	REVISED -

**STATE OF ILLINOIS  
DEPARTMENT OF TRANSPORTATION**

**DETAILS - SIDEROADS AND ENTRANCES**

SCALE: SHEET NO. OF SHEETS STA. TO STA.

F.A.S. RTE.	SECTION	COUNTY	TOTAL SHEETS	SHEET NO.
960	39RS-8, 40RS-10, 41RS-6	MASSAC	38	36
			CONTRACT NO. 78219	
FED. ROAD DIST. NO. ILLINOIS FED. AID PROJECT				