

LOOP SPLICING REQUIREMENTS

MINIMUM 1" (25 mm) HEAT SHRINK TUBING OVERLAP ON WIRE, PVC & SHIELDED CABLE TO FORM WATER TIGHT SEAL

WIDTH (W)	WIDTH (S)
12' (3.7 m)	8' (2.5 m)
13' (4.0 m)	9' (2.8 m)
14' (4.3 m)	10' (3.1 m)
15' (4.6 m)	11' (3.4 m)
16' (4.9 m)	12' (3.7 m)
17' (5.2 m)	13' (4.0 m)
18' (5.5 m)	14' (4.3 m)
19' (5.8 m)	15' (4.6 m)
20' (6.1 m)	18' (4.9 m)
21' (6.4 m)	17' (5.2 m)
22' (6.7 m)	18' (5.5 m)
23' (7.0 m)	19' (5.8 m)
24' (7.3 m)	20' (6.1 m)
25' (7.6 m)	21' (6.4 m)

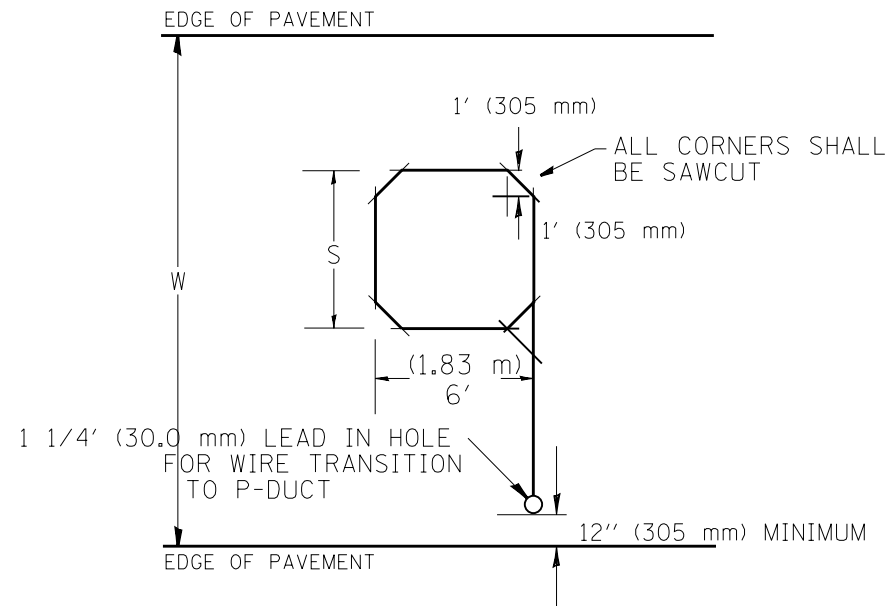

TYPICAL "S" FT. BY 6' (1.83 m) INDUCTION LOOP SAWCUT LAYOUT FOR RAMPS

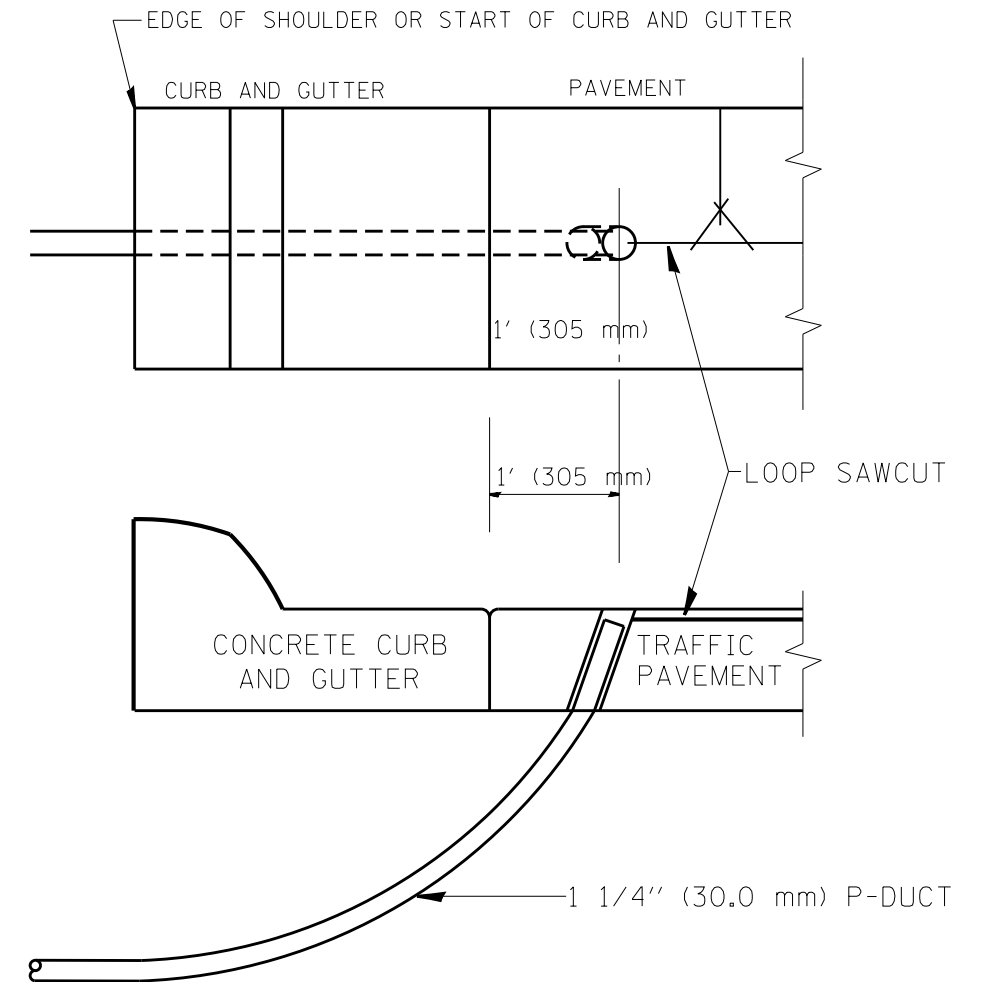

CURB AND GUTTER LOOP LEAD-IN TRANSITION DETAIL

NOTES

1. EACH LOOP SHALL BE SPLICED TO A 4-C NO.18 TWISTED SHIELDED LEAD IN WHEN 150' (45 m) OR MORE FROM CABINET.
2. LOOPS SHALL BE SPLICED IN HANDHOLES ONLY, OTHERWISE WRITTEN PERMISSION SHALL BE OBTAINED FROM TSC ENGINEER.
3. LOOPS SHALL NOT BE SPLICED IN SERIES.
4. EACH LOOP LEAD IN SHALL BE IDENTIFIED AND PERMANENTLY COLOR CODED IN THE COREHOLE, HANDHOLE & CABINETS THRU WHICH THEY ENTER OR PASS AND TAGGED WITH THE CORRECT NOMENCLATURES.

FILE NAME =	USER NAME = mezag	DESIGNED - R.L.	REVISED - 6/94	STATE OF ILLINOIS DEPARTMENT OF TRANSPORTATION TRAFFIC SYSTEMS CENTER	RECTANGULAR INDUCTION LOOP TYPICAL			F.A. RTE.	SECTION	COUNTY	TOTAL SHEETS	SHEET NO.
ca:\pw\work\p\idot\mezag\d0287541\TSC1P.dgn	PLOT SCALE = 100.0000' / in.	DRAWN - G.M.	REVISED - 11/95					90/94	0303-474HB-R	COOK	368	188
PLOT DATE = 7/26/2012	DATE - 6-22-94	CHECKED - R.L.	REVISED - 05/96		SCALE: NONE SHEET NO. OF SHEETS STA. TO STA.			CONTRACT NO. 60F63				
		DATE - 6-22-94	REVISED - 10/96		FED. ROAD DIST. NO. ILLINOIS FED. AID PROJECT							