

**SAFETY EDGE DETAIL**

(APPLIES TO LOCATIONS WITH LESS THAN 3' OF PAVED SHOULDER)

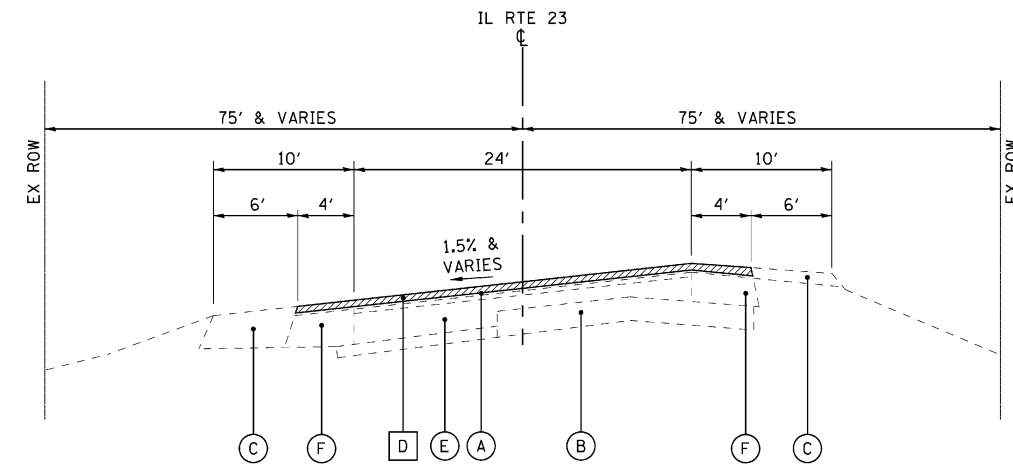

**EXISTING TYPICAL SECTION  
IL ROUTE 23  
STA 203+55 TO STA 221+75**

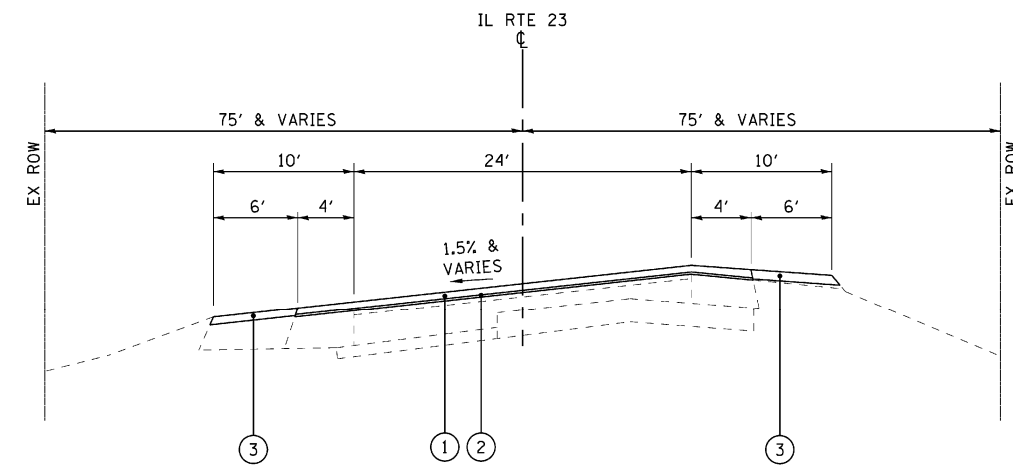

**PROPOSED TYPICAL SECTION  
IL ROUTE 23  
STA 203+55 TO STA 221+75**

**LEGEND**

- (A) EXISTING HMA SURFACE, 3"±
- (B) EXISTING PCC BASE, 10"±
- (C) EXISTING AGGREGATE SHOULDER, 6"±
- (D) HOT-MIX ASPHALT SURFACE REMOVAL, 3"
- (E) EXISTING HOT-MIX ASPHALT BASE COURSE, 10" ±
- (F) EXISTING PAVED SHOULDERS
- (G) EXISTING COMBINATION CONCRETE CURB AND GUTTER, TYPE B-6.24
- [Hatched Box] ITEM TO BE REMOVED
- (1) HOT-MIX ASPHALT SURFACE COURSE, MIX "D", N70 (IL-9.5mm) - 2"
- (2) POLYMERIZED LEVELING BINDER (MACHINE METHOD), IL-4.75, N50 - 1"
- (3) GRADING AND SHAPING SHOULDERS AND AGGREGATE WEDGE SHOULDER, TYPE B
- (SE) SAFETY EDGE (SEE DETAIL) - REQUIRED ON ALL LOCATIONS WITH LESS THAN 3' OF PAVED SHOULDER

COPYRIGHT © 2010 BY BAXTER & WOODMAN, INC. ...  
 LICENSE NO. 185-002123-EXPRES 4/20/2011  
 5/6/09cr



DESIGNED - TMS	REVISED -
DRAWN - BCD	REVISED -
CHECKED - RWL	REVISED -
DATE - 12-12-10	FILE - 100153-w015-TypSec.sht

**STATE OF ILLINOIS  
DEPARTMENT OF TRANSPORTATION**

**ILLINOIS ROUTE 23  
POPLAR ROAD TO INTERSTATE 90  
TYPICAL SECTIONS**

SCALE: NONE STA. TO STA.

F.A.P. RTE.	SECTION	COUNTY	TOTAL SHEETS	SHEET NO.
324	24-RS-4	McHENRY	16	5
FED. ROAD DIST. NO. 1 ILLINOIS FED. AID PROJECT				

CONTRACT NO. 60N34