

IL 53
EXISTING TYPICAL SECTION
 STA. 142+00 TO STA. 149+00
 STA. 162+00 TO STA. 171+00

- LEGEND
- ① EXISTING CONCRETE BASE COURSE (9" - 7" - 9")
 - ② EXISTING HMA SURFACE (9"±)
 - ③ EXISTING HMA WIDENING (9-3/4" - 15-1/4")
 - ④ EXISTING HMA SHOULDERS, 8"
 - ⑤ EXISTING AGGREGATE SHOULDER, 8"
 - ⑥ EXISTING AGGREGATE SUBGRADE, 12"
 - ⑦ EXISTING HMA BINDER COURSE, 10"
 - ⑧ EXISTING SOD
 - ⑨ PROPOSED HMA SURFACE REMOVAL, 2-1/4"
 - ⑩ PROPOSED HMA SURFACE COURSE, MIX "D", N70, 1-1/2"
 - ⑪ PROPOSED POLYMERIZED LEVELING BINDER (MACHINE METHOD), IL-4.75, N50, 3/4"
 - ⑫ PROPOSED AGGREGATE WEDGE SHOULDER, TYPE B
 - ⑬ PROPOSED GRADING AND SHAPING SHOULDERS

THE CONTRACTOR SHALL MILL FIRST PRIOR TO PATCHING

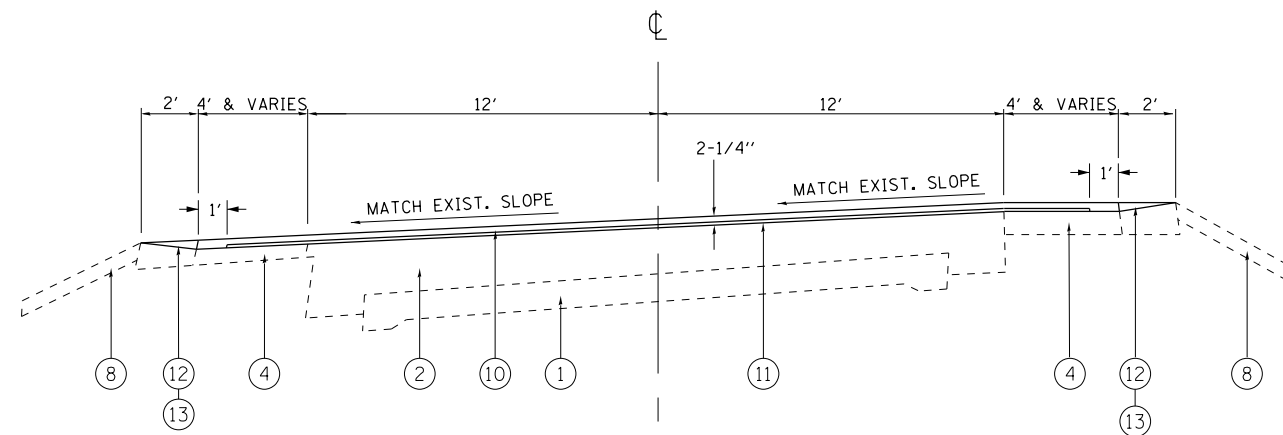

IL 53
PROPOSED TYPICAL SECTION
 STA. 142+00 TO STA. 149+00
 STA. 162+00 TO STA. 171+00