

IL 53
EXISTING TYPICAL SECTION
 STA. 177+00 TO STA. 187+00

- LEGEND
- ① EXISTING CONCRETE BASE COURSE (9" - 7" - 9")
 - ② EXISTING HMA SURFACE (9"±)
 - ③ EXISTING HMA WIDENING (9-3/4" - 15-1/4")
 - ④ EXISTING HMA SHOULDERS, 8"
 - ⑤ EXISTING AGGREGATE SHOULDER, 8"
 - ⑥ EXISTING AGGREGATE SUBGRADE, 12"
 - ⑦ EXISTING HMA BINDER COURSE, 10"
 - ⑧ EXISTING SOD
 - ⑨ PROPOSED HMA SURFACE REMOVAL, 2-1/4"
 - ⑩ PROPOSED HMA SURFACE COURSE, MIX "D", N70, 1-1/2"
 - ⑪ PROPOSED POLYMERIZED LEVELING BINDER (MACHINE METHOD), IL-4.75, N50, 3/4"
 - ⑫ PROPOSED AGGREGATE WEDGE SHOULDER, TYPE B
 - ⑬ PROPOSED GRADING AND SHAPING SHOULDERS

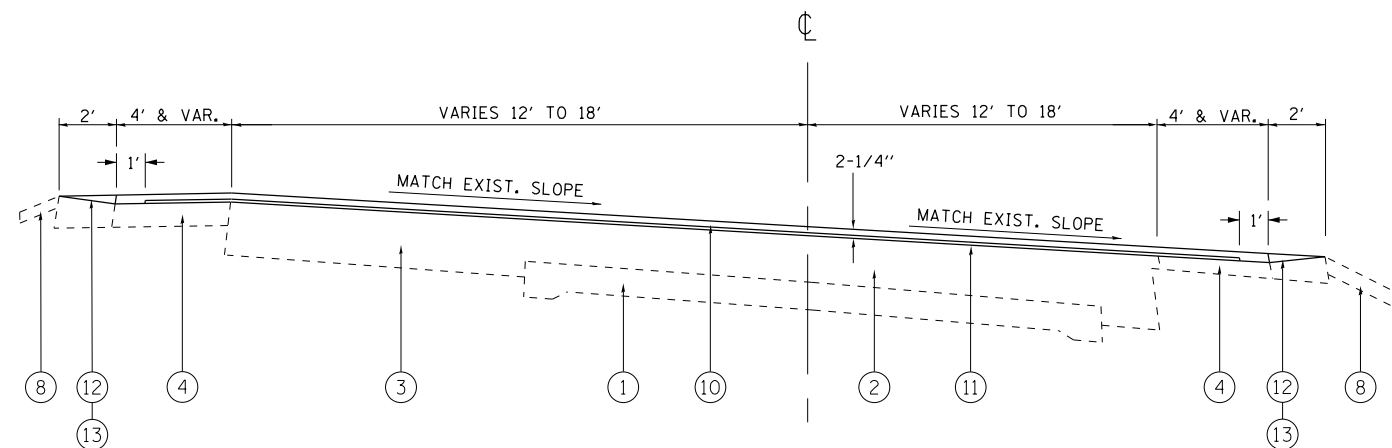

IL 53
PROPOSED TYPICAL SECTION
 STA. 177+00 TO STA. 187+00

THE CONTRACTOR SHALL MILL FIRST PRIOR TO PATCHING

FILE NAME =	USER NAME = tarigfm	DESIGNED -	REVISED -	STATE OF ILLINOIS DEPARTMENT OF TRANSPORTATION	IL 53 (WO LAKE COOK RD. TO OLD MCHENRY RD.) EXISTING AND PROPOSED TYPICAL SECTIONS	F.A.U. RTE.	SECTION	COUNTY	TOTAL SHEETS	SHEET NO.	
et:\pw\work\p\dot\tarigfm\d0251703\013111	sh-t-plan.dgn	DRAWN -	REVISED -			1261	530-RS-5	LAKE	25	8	
	PLOT SCALE = 100.0000' / in.	CHECKED -	REVISED -			CONTRACT NO. 60N41					
	PLOT DATE = 3/27/2013	DATE -	REVISED -			SCALE:	SHEET NO.	OF SHEETS	STA.	TO STA.	ILLINOIS FED. AID PROJECT