

DESIGN SPECIFICATIONS

2010 AASHTO LRFD Bridge Design Specifications,
5th Ed. with 2010 Interims

DESIGN STRESSES

FIELD UNITS

$f'_c = 3,500$ psi
 $f_y = 60,000$ psi (Reinforcement)
 $f_y = 50,000$ psi (M270 Grade 50)

PRECAST UNITS

$f'_c = 6,000$ psi
 $f'_ci = 5,000$ psi
 $f_{pu} = 270,000$ psi ($\frac{1}{2}$ " ϕ low lax stands)
 $f_{pbt} = 201,960$ psi ($\frac{1}{2}$ " ϕ low lax strands)

LOADING HL-93

Allow 50#/sq. ft. for future wearing surface.

SEISMIC DATA

Seismic Performance Zone (SPZ) = 1
Design Spectral Acceleration at 1.0 sec. (S_{D1}) = 0.094 g
Design Spectral Acceleration at 0.2 sec. (S_{D5}) = 0.171 g
Soil Site Class = C

CURVE DATA (C.H. 50)

$\Delta = 47^\circ 10' 49.46''$
 $D = 7^\circ 30'$
 $T = 333.38'$
 $L = 628.66'$
 $E = 69.618'$
 $R = 763.44'$
P.I. = Sta. 23+04.98
S.E. = 0.015 ft/ft
Attain S.E. from Sta. 18+90 to Sta. 19+50,
full S.E. from Sta. 19+50 to Sta. 25+85.26.

CURVE DATA (F.A.I. 74)

$\Delta = 17^\circ 19' 03''$
 $D = 1^\circ 08'$
 $T = 769.90'$
 $L = 1528.02'$
 $E = 58.29'$
 $R = 5055.65'$
P.I. = Sta. 1551+13.42
S.E. = 0.032 ft/ft

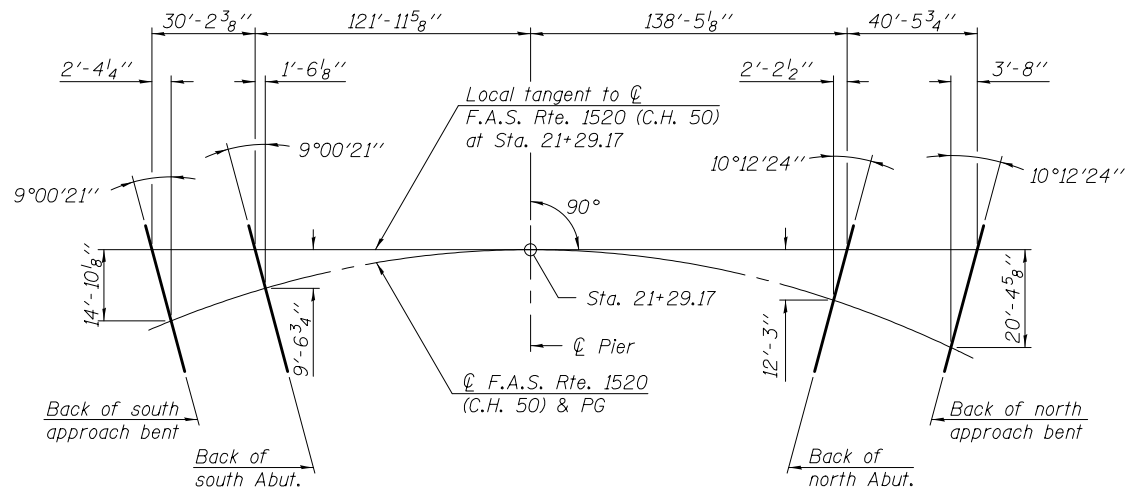

OFFSET SKETCH

INDEX OF SHEETS

- 1 - General Plan & Elevation
- 2 - General Data
- 3 - Footing Layout
- 4-7 - Top of Slab Elevations
- 8 - Top of Vaulted Abutment Slab Elevations
- 9 - Top of South Vaulted Abutment Slab Elevations
- 10 - Top of North Vaulted Abutment Slab Elevations
- 11 - Top of South Approach Slab Elevations
- 12 - Top of North Approach Slab Elevations
- 13-15 - Superstructure
- 16-20 - Superstructure Details
- 21 - South Vaulted Abutment Approach Span
- 22-24 - South Vaulted Abutment Approach Span Details
- 25 - North Vaulted Abutment Approach Span
- 26-28 - North Vaulted Abutment Approach Span Details
- 29-31 - South Bridge Approach Slab Details
- 32-34 - North Bridge Approach Slab Details
- 35 - Bridge Fence Railing, Parapet Mounted
- 36 - Parapet Railing
- 37 - Preformed Joint Strip Seal
- 38 - Structural Steel
- 39-41 - Structural Steel Details
- 42 - Vaulted Abutment Framing Plan
- 43 - 36" PPC I-Beam (South Abutment)
- 44 - 36" PPC I-Beam (North Abutment)
- 45 - 36" PPC I-Beam Details
- 46 - Bearing Details
- 47-49 - South Abutment
- 50-51 - South Abutment Details
- 52-54 - North Abutment
- 55-56 - North Abutment Details
- 57 - Pier
- 58 - Metal Shell Pile Details
- 59-62 - Soil Boring Logs

Fasteners shall be ASTM A325 Type 1, mechanically galvanized bolts. Bolts $\frac{7}{8}$ in. ϕ , holes $\frac{15}{16}$ in. ϕ , unless otherwise noted.
Calculated weight of Structural Steel = 474,930 Lbs. (AASHTO M270, Grade 50)
No field welding is permitted except as specified in the contract documents.
Reinforcement bars designated (E) shall be epoxy coated.
Plan dimensions and details relative to existing plans are subject to nominal construction variations. The Contractor shall field verify existing dimensions and details affecting new construction and make necessary approved adjustments prior to construction or ordering of materials. Such variations shall not be cause for additional compensation for a change in scope of the work, however, the Contractor will be paid for the quantity actually furnished at the unit price bid for the work.
Bearing seat surfaces shall be constructed or adjusted to the designated elevations within a tolerance of $\frac{1}{8}$ inch (0.01 ft.). Adjustment shall be made either by grinding the surface or by shimming the bearings.
Concrete Sealer shall be applied to the designated areas of the abutments.
The Organic Zinc Rich Primer / Epoxy / Urethane Paint System shall be used for painting of new structural steel except where otherwise noted. The entire system shall be shop applied, with the exception of the exterior surfaces and bottom of the bottom flange of fascia beams, masked off connection surfaces, field installed fasteners, and damaged areas, all of which shall be touched up and finish coated in the field. The color of the final finish coat for all interior steel surfaces shall be Gray, Munsell No. 5B 7/1. The color of the final finish coat for the exterior and bottom flange of the fascia beams shall be Interstate Green, Munsell No. 7.5G 4/8.

The embankment configuration shown shall be the minimum that must be placed and compacted prior to construction of the abutments.
Slopewall shall be reinforced with welded wire fabric, 6" x 6" - W4.0 x W4.0, weighing 58 lbs. per 100 sq. ft.
Slipforming of the parapets is not allowed.
The Contractor shall retain the services of an engineering firm, prequalified in the IDOT consultant selection category of Highway Bridges Advanced Typical, for preparation of the Structural Assessment Report. Contractor's pre-approval shall not be applicable for this project. See Special Provision.
Current Ratings on File for Existing Structure 010-0157:
Inventory: HS 6.0
Operating: HS 10.0
Live Load Restrictions: Yes (15 Tons)
Inventory and Operating Ratings and Live Load Restrictions are provided for information only. Inventory and Operating Ratings are based on HS loading and configuration. Live Load Restrictions are based on Illinois legal loads and configurations. The Ratings and Live Load Restrictions are not necessarily representative of capacities to support the Contractor's equipment.
The Contractor is advised that the existing structure contains members that are in a deteriorated condition with reduced load carrying capacity. It is the Contractor's responsibility to account for the condition of the existing structure when developing construction procedures for the complete or partial removal, or replacement of the structure.
An Existing Structure Information Package is available upon request as noted in the special provisions.

TOTAL BILL OF MATERIAL

ITEM	UNIT	SUPER	SUB	TOTAL
Removal of Existing Structures	Each			1
Structure Excavation	Cu. Yd.		435	435
Concrete Structures	Cu. Yd.		388.7	388.7
Concrete Superstructure	Cu. Yd.	693.4		693.4
Bridge Deck Grooving	Sq. Yd.	1,283		1,283
Protective Coat	Sq. Yd.	2,475		2,475
Furnishing and Erecting Precast Prestressed Concrete I-Beams, 36 in.	Foot	337		337
Furnishing and Erecting Structural Steel	L. Sum			1
Stud Shear Connectors	Each	3,510		3,510
Reinforcement Bars, Epoxy Coated	Pound	154,970	48,870	203,840
Bridge Fence Railing	Foot	335		335
Parapet Railing	Foot	332		332
Slope Wall 4 Inch	Sq. Yd.		207	207
Furnishing Metal Shell Piles 12" x 0.25"	Foot		1,268	1,268
Furnishing Metal Shell Piles 14" x 0.25"	Foot		667	667
Driving Piles	Foot		1,935	1,935
Test Pile Metal Shells	Each		5	5
Pile Shoes	Each		67	67
Name Plates	Each	1		1
Preformed Joint Strip Seal	Foot	96		96
Elastomeric Bearing Assembly, Type II	Each	16		16
Anchor Bolts, 1"	Each		32	32
Anchor Bolts, 1 1/4"	Each		16	16
Concrete Sealer	Sq. Ft.		2,922	2,922

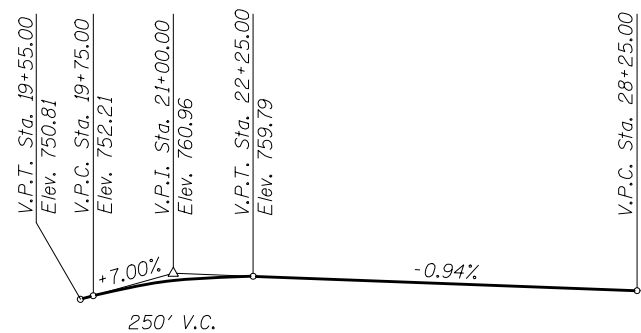

PROFILE GRADE (C.H. 50)

STATION 21+29.17
BUILT 20 BY
STATE OF ILLINOIS
F.A.I. RT. 74 SEC. 10-4BR
LOADING HL-93
STRUCTURE NO. 010-0289

NAME PLATE
See Std. 515001

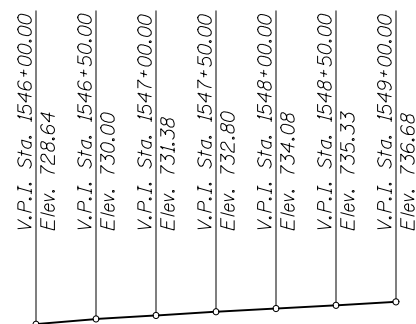

PROFILE GRADE (E.B. I-74)

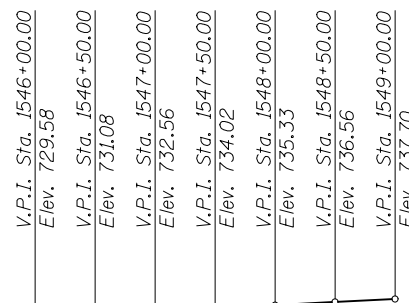

PROFILE GRADE (W.B. I-74)

* 1:6 (V:H)

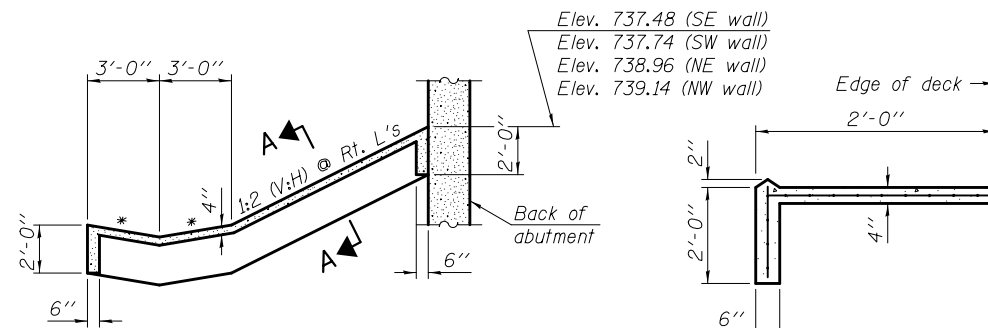

SECTION THRU CONCRETE SLOPEWALL

SECTION A-A

DESIGNED - DEWEY H. COULTAS
CHECKED - NICHOLAS R. BARNETT
DRAWN - MICHAEL B. MOSSMAN
CHECKED - D.H.C. / N.R.B.

EXAMINED
PASSED
ACTING ENGINEER OF BRIDGE DESIGN
ACTING ENGINEER OF BRIDGES AND STRUCTURES

DATE - FEBRUARY 25, 2013
REVISED
REVISED

STATE OF ILLINOIS
DEPARTMENT OF TRANSPORTATION

GENERAL DATA
STRUCTURE NO. 010 - 0289

SHEET NO. 2 OF 62 SHEETS

F.A.I. RTE.	SECTION	COUNTY	TOTAL SHEETS	SHEET NO.
74	10-4BR	CHAMPAIGN	290	87
CONTRACT NO. 70700			ILLINOIS FED. AID PROJECT	