

PROPOSED EXPANSION JOINT DETAIL
(East and West Abutment)

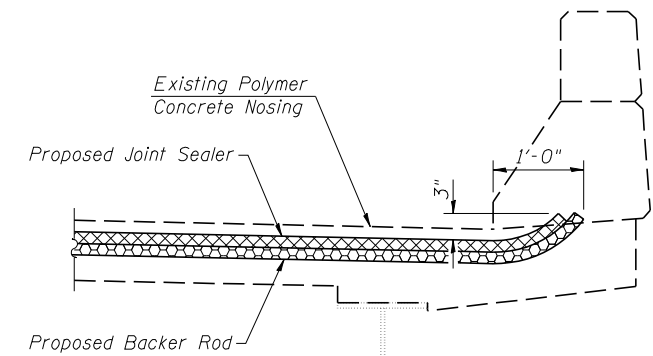

SECTION AT PARAPET

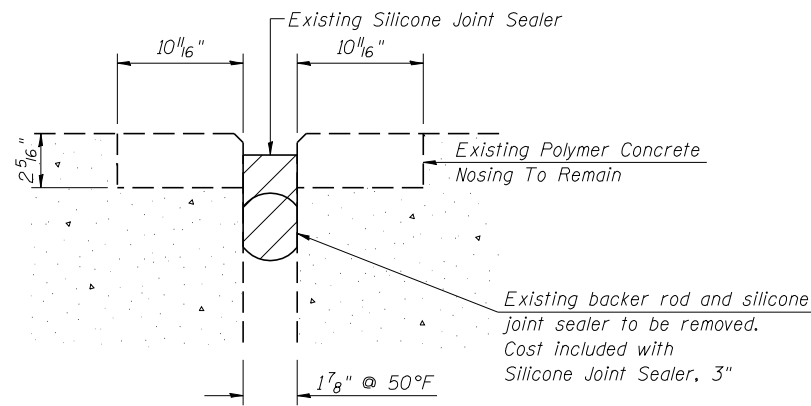

TYPICAL EXISTING JOINT CROSS SECTION
(East and West Abutment)

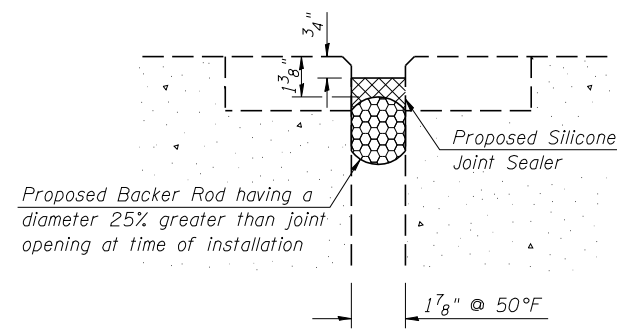

TYPICAL PROPOSED JOINT CROSS SECTION
(East and West Abutment)

BILL OF MATERIAL

Item	Unit	Total
Silicone Joint Sealer, 3"	Foot	62

**SILICONE JOINT SEALER
EAST AND WEST ABUTMENT
S.N. 054-0062**