

DETAIL OF CONCRETE COLLAR FOR BOX CULVERT EXTENSIONS

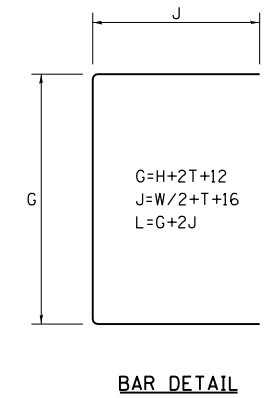
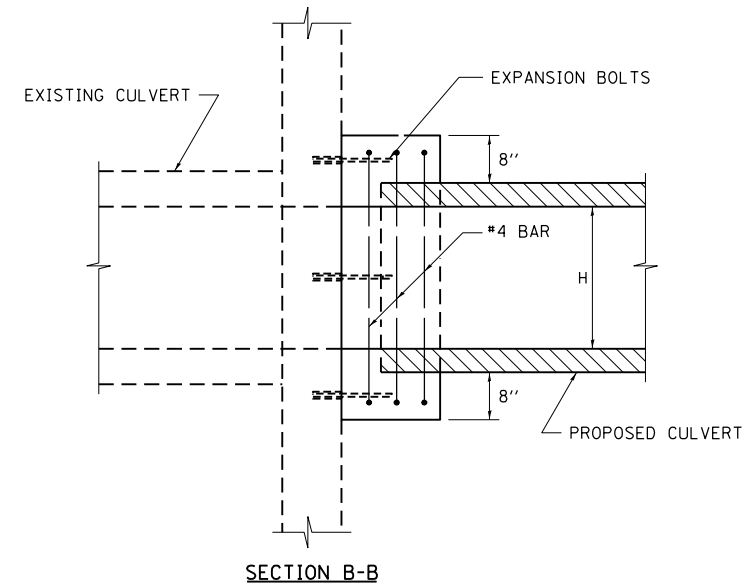
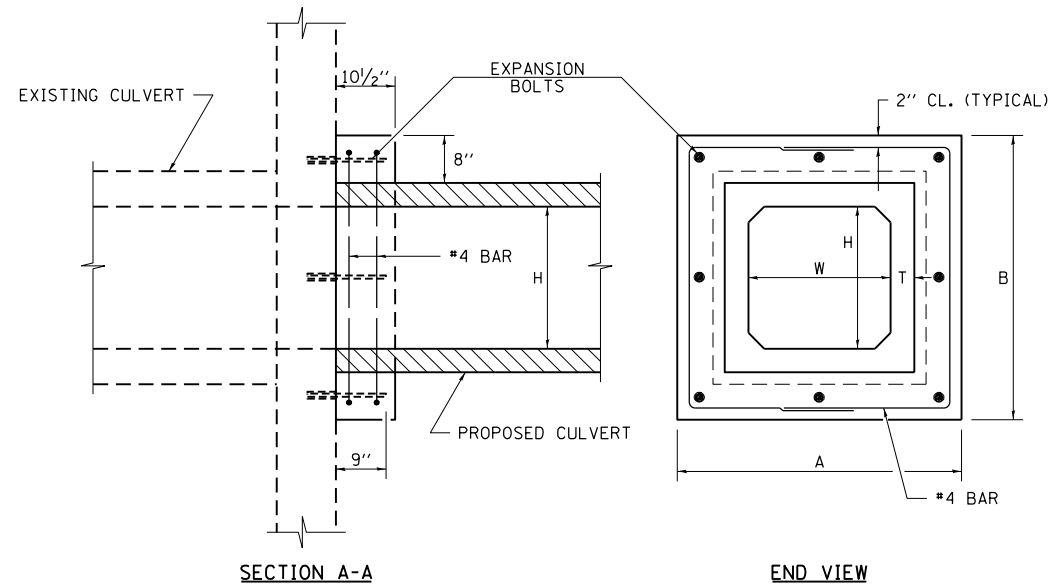
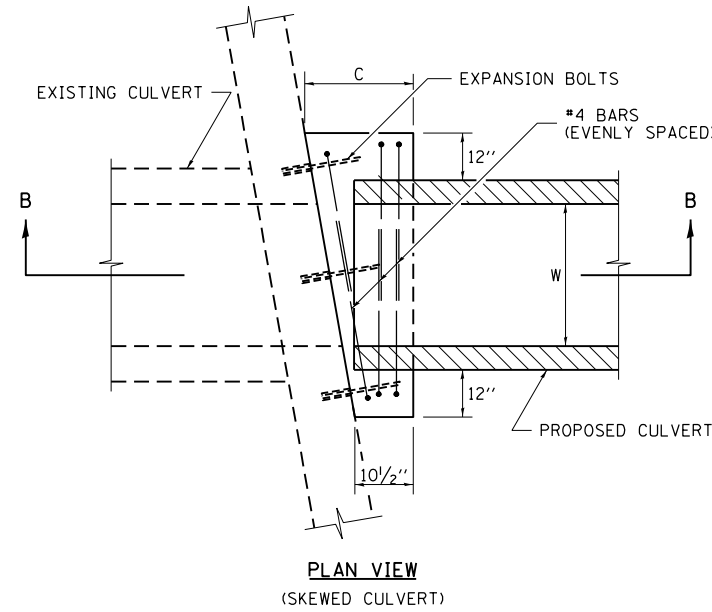
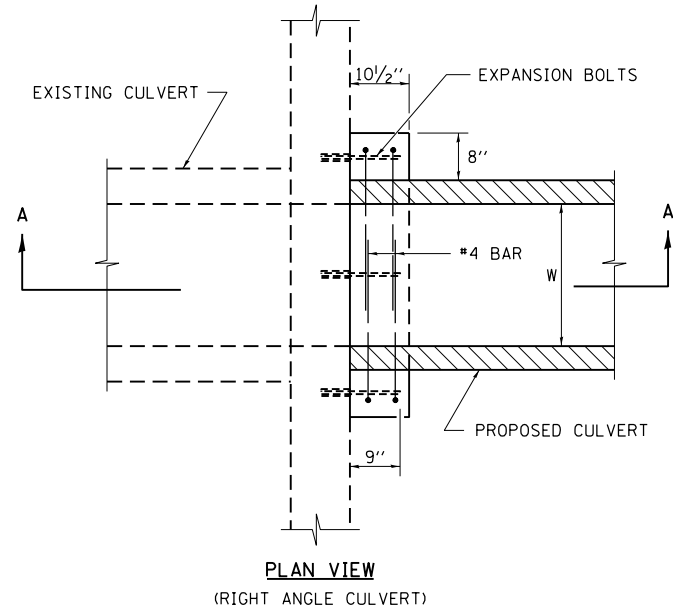

CONCRETE COLLAR SCHEDULE		DIMENSIONS						REINFORCEMENT BARS					CONCRETE COLLAR	3/4" EXPANSION BOLTS
		A	B	C	W	H	T	G	J	L	NUMBER BARS	QTY		
SIDE	STATION	IN	IN	IN	IN	IN	IN	IN	IN	IN	EA	LB	CU YD	EA
LT	811+97	56	48	33	24	24	4	44	32	108	6	37	0.78	8
RT	811+97	56	48	33	24	24	4	44	32	108	6	37	0.78	8
LT	823+80	56	48	33	24	24	4	44	32	108	6	37	0.78	8
RT	823+80	56	48	33	24	24	4	44	32	108	6	37	0.78	8
TOTALS												148	3.00	32

NOTE: EXPANSION BOLTS SHALL CONSIST OF SELF-DRILLING EXPANSION SHIELDS AND HOOKED BOLTS. HOOKED BOLTS SHALL EXTEND A MINIMUM OF 9" INTO THE NEW CONCRETE.