

PCC SURFACE REMOVAL – BUTT JOINT – COLUMBIA AVENUE

STA 30+36.02 TO STA 30+63.64

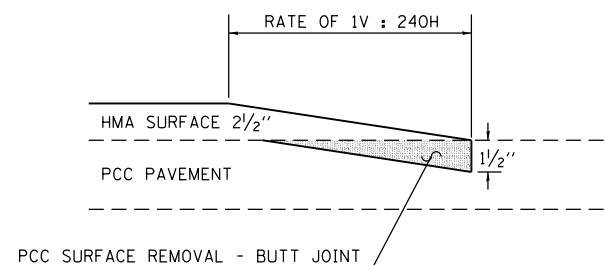

PCC SURFACE REMOVAL – BUTT JOINT – NORTH MARKET STREET

STA 198+00.15 TO STA 198+50.15

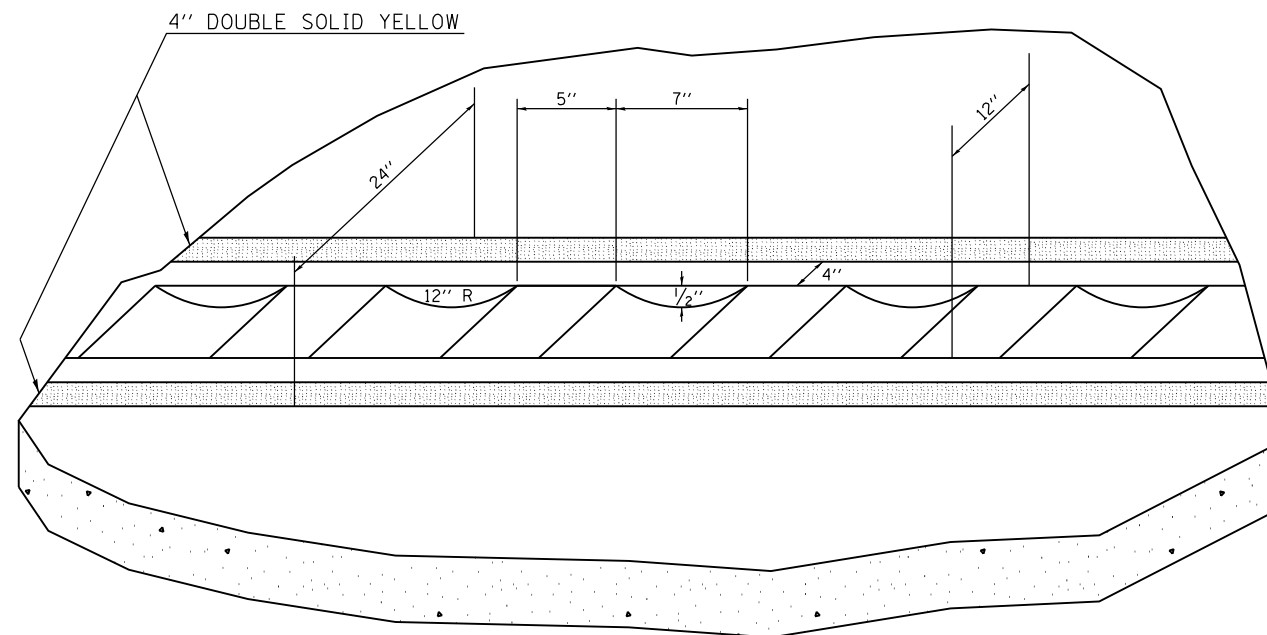

GENERAL NOTES:

- THIS WORK WILL BE DONE ACCORDING TO SECTION 642 OF THE SPECIFICATION BOOK EXCEPT AS FOLLOWS:
- SEE STANDARD 780001 FOR STRIPING.
- RUMBLE STRIPS SHALL NOT BE PLACED ON BRIDGES.
- ALL RUMBLE STRIPS SHALL BE MILLED.
- CENTERLINE RUMBLE STRIPS SHALL BE CONTINUOUS THROUGH THE FOLLOWING STATION RANGES:
 FAP 312 (ILLINOIS ROUTE 3)
 STATION 2028+85.00 TO STATION 2050+44.73
 STATION 2067+92.19 TO STATION 2073+95.10
- METHOD OF MEASUREMENT: THIS WORK WILL BE MEASURED FOR PAYMENT IN FEET ALONG THE CENTERLINE.
- THIS WORK WILL BE PAID FOR AT THE CONTRACT UNIT PRICE PER FOOT - RUMBLE STRIP
- THE PAVEMENT MARKING WILL BE PAID FOR AT THE CONTRACT UNIT PRICE PER FOOT FOR PREFORMED PLASTIC PAVEMENT MARKING, TYPE B - INLAID - LINE 4 INCH.

DETAILS OF 2' WIDE RUMBLE STRIP AT CENTERLINE

FAP 312 (ILLINOIS ROUTE 3)

LAST SAVED = 1/25/2013
 PEN TABLE = 1/25/2013
 PLOT DRIVER = pdfplotlayers.plt

FILE NAME = AGGREGATE DITCH.dgn	USER NAME = JLM	DESIGNED - KCM	REVISED -
		DRAWN - JLM	REVISED -
		CHECKED - TMM	REVISED -
		DATE -	REVISED -
PLOT SCALE =			
PLOT DATE = 12:38:51 PM			

**STATE OF ILLINOIS
DEPARTMENT OF TRANSPORTATION**

**HORNER &
SHIRIN, INC.
ENGINEERS**

MISCELLANEOUS DETAILS
END TAPER, BUTT JOINTS AND RUMBLE STRIP

SCALE: NONE SHEET NO. 18 OF 22 SHEETS STA. TO STA.

F.A.P. RTE.	SECTION	COUNTY	TOTAL SHEETS	SHEET NO.
312	68-WRS-1	MONROE	760	482
CONTRACT NO. 76817				
FED. ROAD DIST. NO. ILLINOIS FED. AID PROJECT				