

$\frac{3}{4}$ "  $\phi$  stainless steel U-bolt.  
Provide two washers and two hexagon locknuts. (4)  
 $\frac{13}{16}$ " x 2" slots on  $\phi$  10"  $\phi$  pipe.  
(4 slots required per pipe)

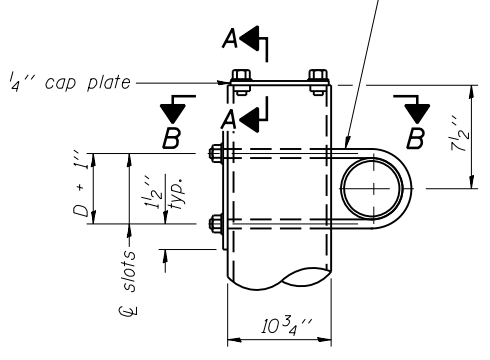

**DETAIL A**

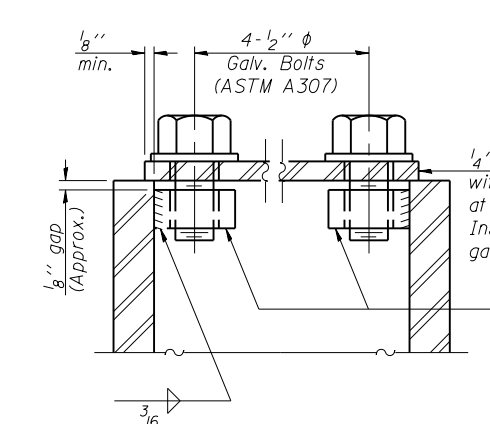

**SECTION A-A**

As an alternate to bolts, may use galvanized drive-fit caps installed after galvanizing frame.

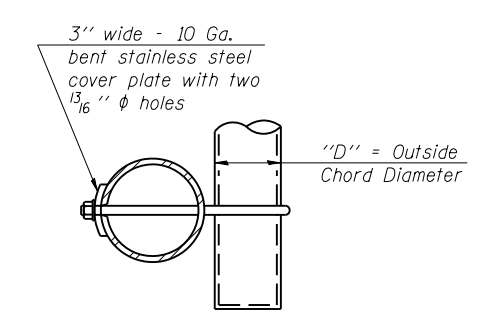

**SECTION B-B**

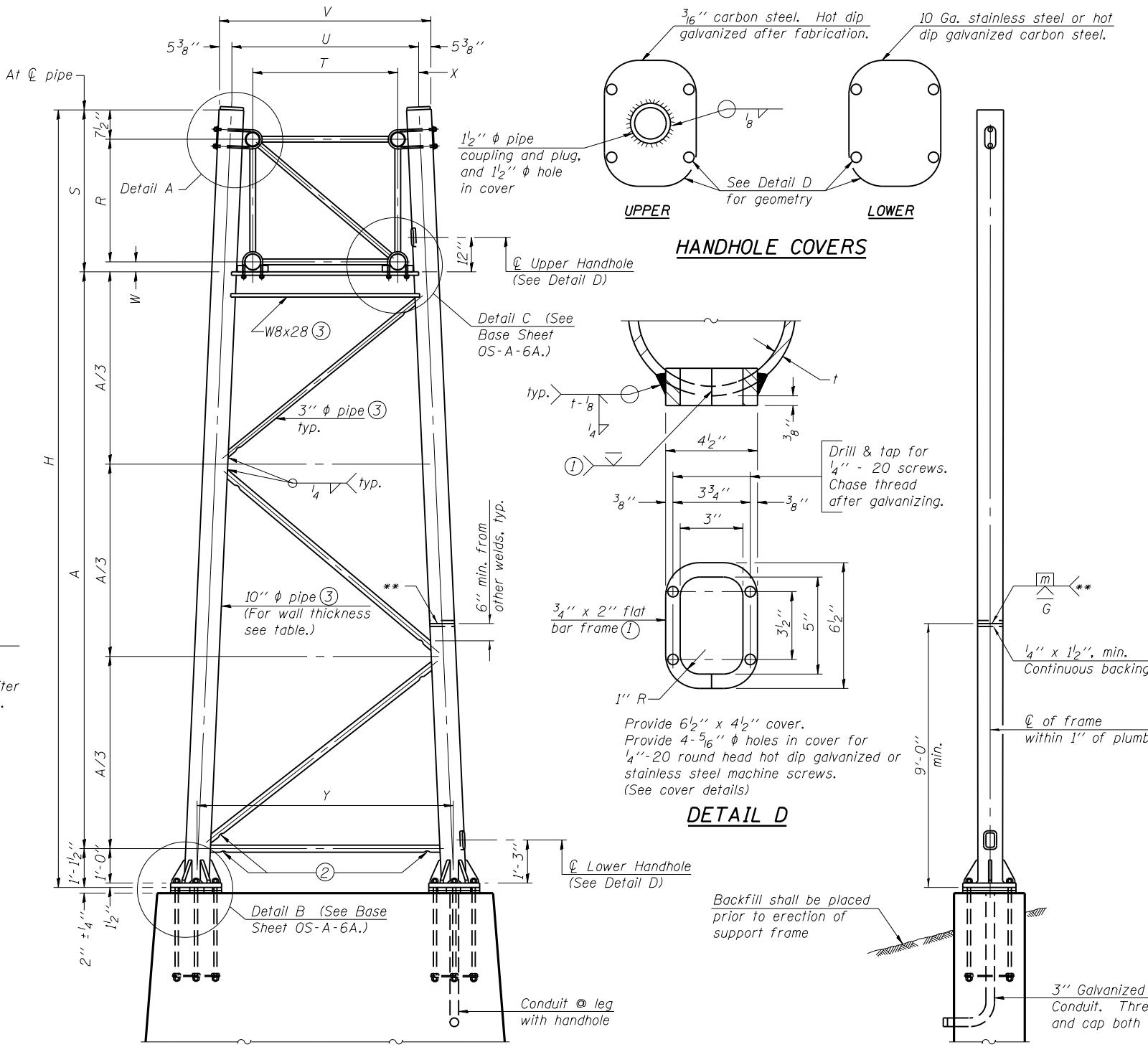

For Foundation Details, see base sheet OS-F3 (Spread Footing) or OS4-F3 (Drilled Shaft).

**SIDE ELEVATION**

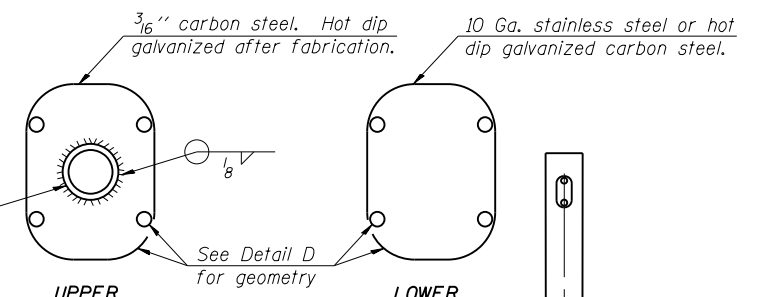

**HANDHOLE COVERS**

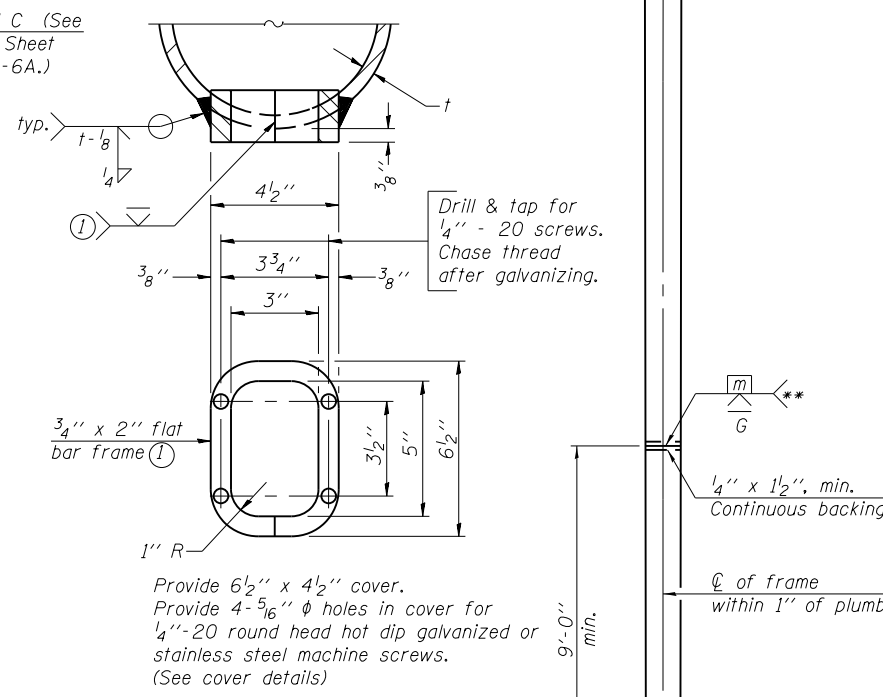

**DETAIL D**

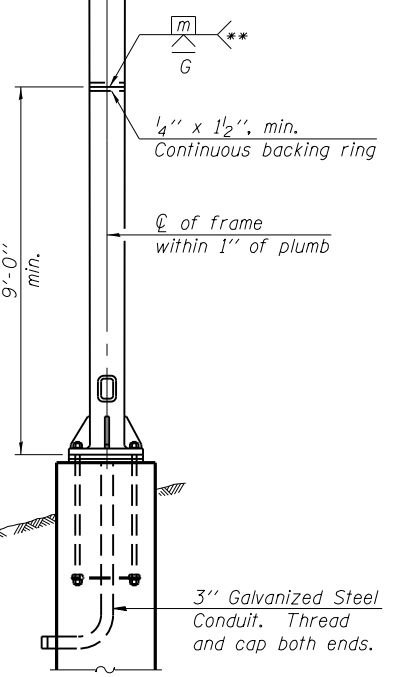

**END ELEVATION**

Support Design Loads: See Base Sheet OS-A-1 for design and loading criteria.  
Load combinations checked include deadload plus:  
a) 100% wind normal to sign, 20% parallel to sign  
b) 60% wind normal to sign, 30% parallel to sign

- ① In lieu of fabricated handhole frame as shown, may cut from 2" plate (rolling direction vertical). All cut faces to be ground to ANSI Roughness of 500  $\mu$ m or less.
- ② Galvanizing vent holes of adequate size shall be provided on underside at each end of bracing pipes. Alternately, holes may be provided in wall of pipe column. All vent holes shall be drilled and de-burred, typ.
- ③ Steel pipe, plate, carbon steel handhole covers and rolled sections shall be hot dip galvanized after fabrication. Painting is not permitted. See Base Sheet OS-A-1.
- ④ See General Notes for fasteners.
- ⑤ Dimensions shown are based on selection criteria in the Sign Structures Manual. Nonstandard applications must have dimensions verified or amended as appropriate.
- ⑥ "H" based on 15'-0" or actual sign height, whichever is greater.

| Truss Type | Dimensions |           |       |       |            |        |        |       |
|------------|------------|-----------|-------|-------|------------|--------|--------|-------|
|            | R          | S         | T     | U     | V          | W      | X      | Y     |
| I-A        | 4'-6"      | 5'-5 1/2" | 4'-0" | 5'-6" | 6'-4 3/4"  | 4"     | 9"     | 8'-3" |
| II-A ⑤     | 5'-3"      | 6'-3 1/4" | 4'-6" | 6'-1" | 6'-11 3/4" | 4 3/4" | 9 1/2" | 8'-3" |

**10"  $\phi$  PIPE TRUSS SUPPORT FRAME**

\*\* One butt welded joint is allowed only on one post per support frame. If used, weld procedure must be pre-approved by Engineer and joint shall receive 100% RT or UT (tension criteria) at Contractor's expense.

OS-A-6

6-1-12

|  |                       |            |           |
|--|-----------------------|------------|-----------|
| FILE NAME =  | USER NAME = \$USER\$  | DESIGNED - | REVISED - |
| ei:\p\work\p\dot\col\emm\d0339264\78362-sh1-sgnstr.dgn |                       | DRAWN -    | REVISED - |
| \$MODELNAME\$  | PLOT DATE = 3/29/2013 | CHECKED -  | REVISED - |
|  |                       | DATE -     | REVISED - |

**STATE OF ILLINOIS  
DEPARTMENT OF TRANSPORTATION**

**OVERHEAD SIGN STRUCTURES  
SUPPORT FRAME FOR ALUMINUM TRUSS**

SCALE: SHEET OF SHEETS STA. TO STA.

| Structure Number | Station | Support |       | Truss Type | Pipe Wall Thickness | H ⑥    | A      |
|------------------|---------|---------|-------|------------|---------------------|--------|--------|
|                  |         | Left    | Right |            |                     |        |        |
| 9S091U051R003.7  | 376+75  |         | X     | II-A       | 0.365               | 27.44' | 20.04' |
| 9S091U051R003.7  | 376+75  | X       |       | II-A       | 0.365               | 27.20' | 19.80' |
|                  |         |         |       |            |                     |        |        |
|                  |         |         |       |            |                     |        |        |
|                  |         |         |       |            |                     |        |        |
|                  |         |         |       |            |                     |        |        |
|                  |         |         |       |            |                     |        |        |
|                  |         |         |       |            |                     |        |        |
|                  |         |         |       |            |                     |        |        |

|                           |         |         |              |
|---------------------------|---------|---------|--------------|
| • VARIOUS ROUTES          |         |         |              |
| F.A.I. RTE.               | SECTION | COUNTY  | TOTAL SHEETS |
|                           |         |         | 34           |
| D9 SAFETY SIGNAGE 2013-1  |         | VARIOUS | 27           |
| CONTRACT NO. 78362        |         |         |              |
| ILLINOIS FED. AID PROJECT |         |         |              |