

ROUTE NO.	SECTION	COUNTY	SHEET NO.	TOTAL SHEETS
FAS452	*	FULTON	26	9
FED. ROAD DIST. NO. 7		ILLINOIS	FED. AID PROJECT	

* 09-00130-05-BR

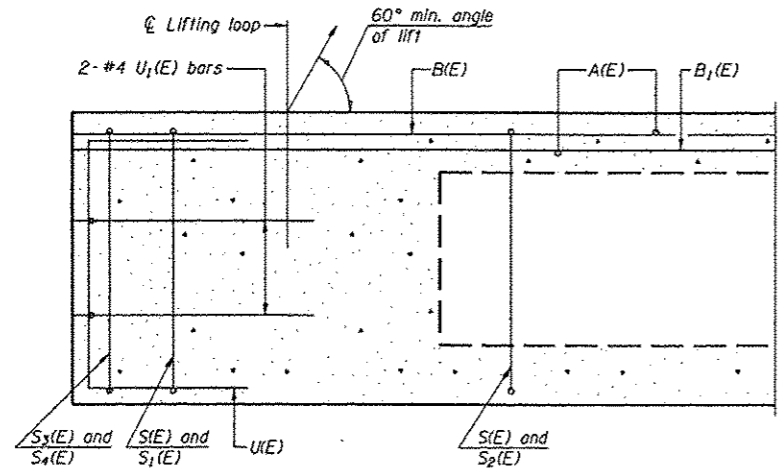

SECTION C-C

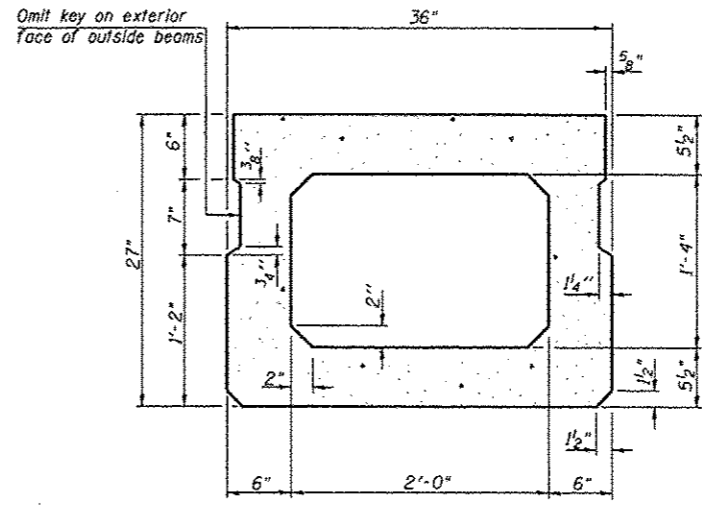

SECTION A-A
(Showing dimensions)

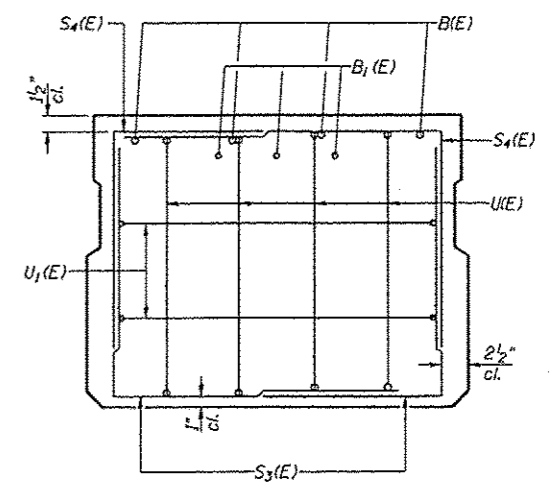

VIEW B-B

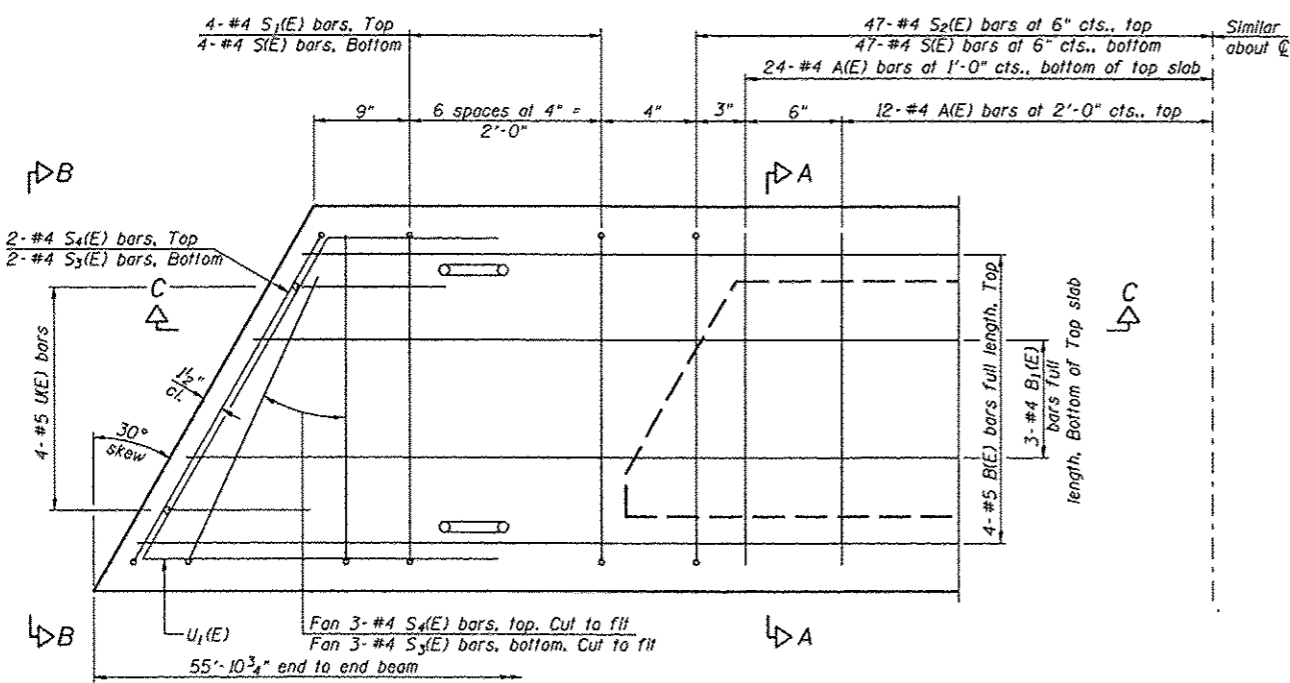

PLAN VIEW

Note: Spacing of S1(E) and S2(E) bars may be adjusted up to 4" in the immediate area of the transverse tie diaphragms to miss the block outs for the transverse ties.

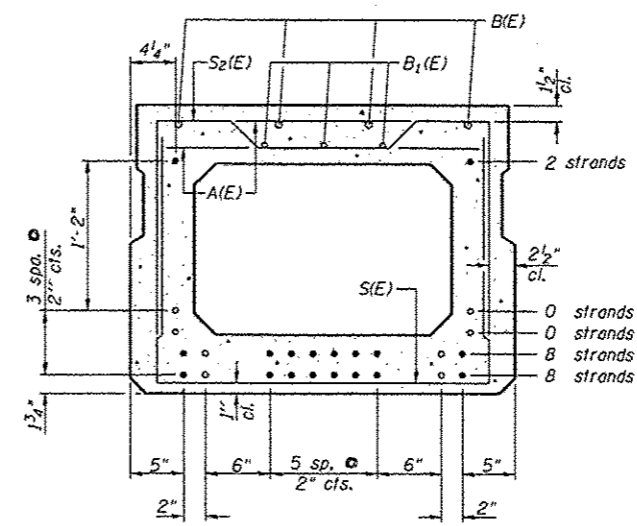

SECTION A-A
(Showing reinforcement and permissible strand locations)
Note: Place the number of strands specified in each row symmetrically about the centerline of beam in the permissible strand locations shown.

BAR LIST
ONE BEAM ONLY
(For information only)

Bar	No.	Size	Length	Shape
A(E)	72	#4	2'-7"	—
B(E)	16	#5	16'-0"	—
B1(E)	12	#4	16'-0"	—
S1(E)	104	#4	6'-5"	—
S2(E)	8	#4	5'-11"	—
S3(E)	96	#4	6'-2"	—
S4(E)	10	#4	4'-6"	—
U1(E)	8	#5	4'-6"	—
U2(E)	4	#4	6'-8"	—

Note: See sheet 4 of 4 for additional details and Bill of Material.

See "CONCRETE WEARING SURFACE" sheet for details on the pairs of (D/E) bars at each embed anchor for SM rolling. The cost shall be included with the cost of the deck beams.

27" x 36" PPC DECK BEAM
STRUCTURE NO. 092-3457
SPAN 2

PD-2736-L 11/1/09

DSGN	K.J. Hoffmann				
DR	K.J. Hoffmann				
CHK	J.R. Wolf				
APVD	J.A. Fraenhoffer	NO.	DATE	REVISION	BY



FRAUENHOFFER & ASSOCIATES
A division of Engineering Resource Associates, Inc.
Consulting Engineers, Scientists, & Surveyors

3002 CROSSING COURT
CHAMPAIGN, IL 61822
PHONE (217) 351-6268
FAX (217) 355-1902

SUPERSTRUCTURE DETAILS (SHEET 3 OF 4)
FAS 452 (CH2) OVER LASWELL BRANCH OF PUT CREEK
SEC 08-00130-05-BR
FULTON COUNTY

SHEET	9
DWG NO.	9029SUP.dgn
DATE	DEC 2012
PROJ NO.	9029