

ROUTE	SECTION	COUNTY	TOTAL SHEETS	SHEET NO.
TR 164	10-06119-00-BR	SALINE	13	9
PROJECT NO. BROS-165(36)			CONTRACT NO. 99489	

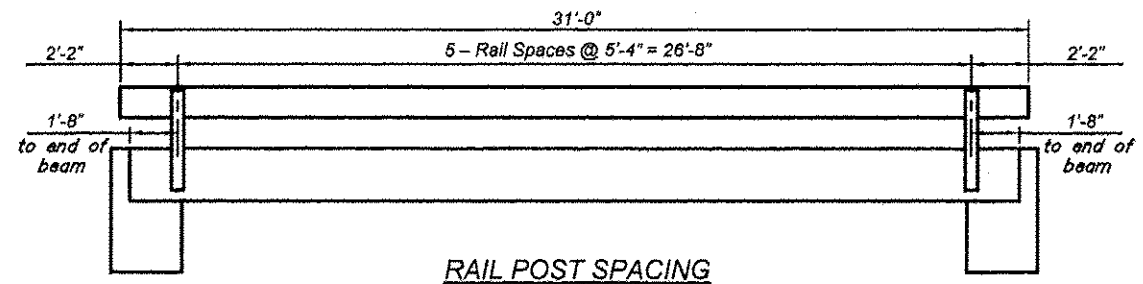

RAIL POST SPACING

NOTE: Curled End Section to be included in the cost for Steel Railing, Type S1 Four (4) required.

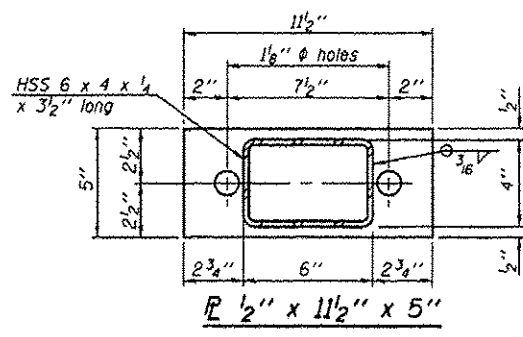

RAIL POST

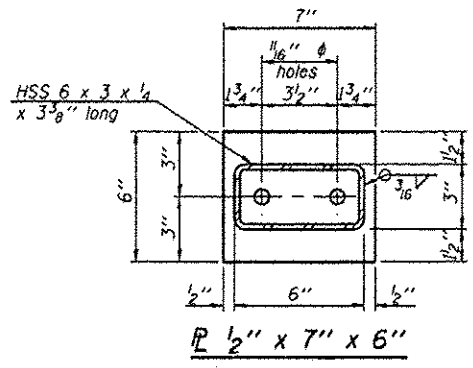

RAIL POST

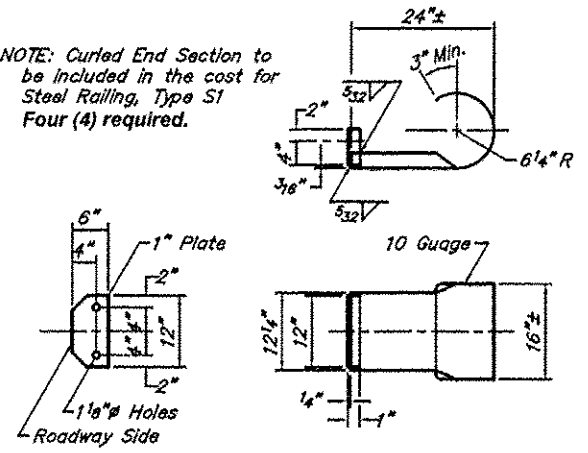

CURLLED END SECTION DETAILS

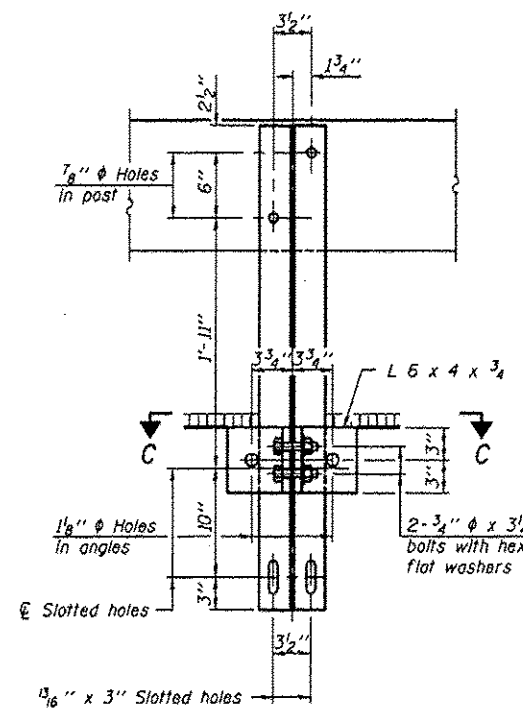

SECTION B-B

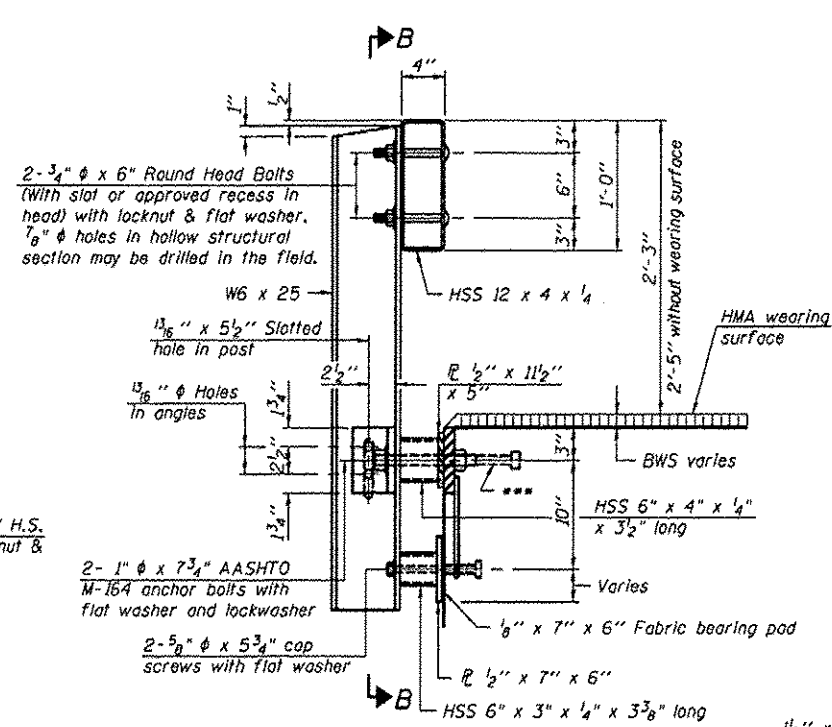

SECTION AT RAILING POST

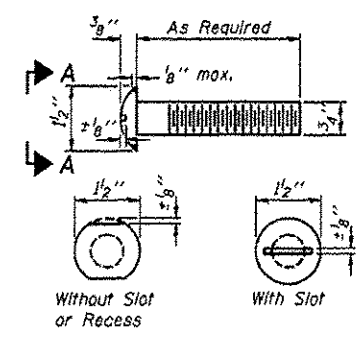

VIEW A-A ROUND HEAD BOLT

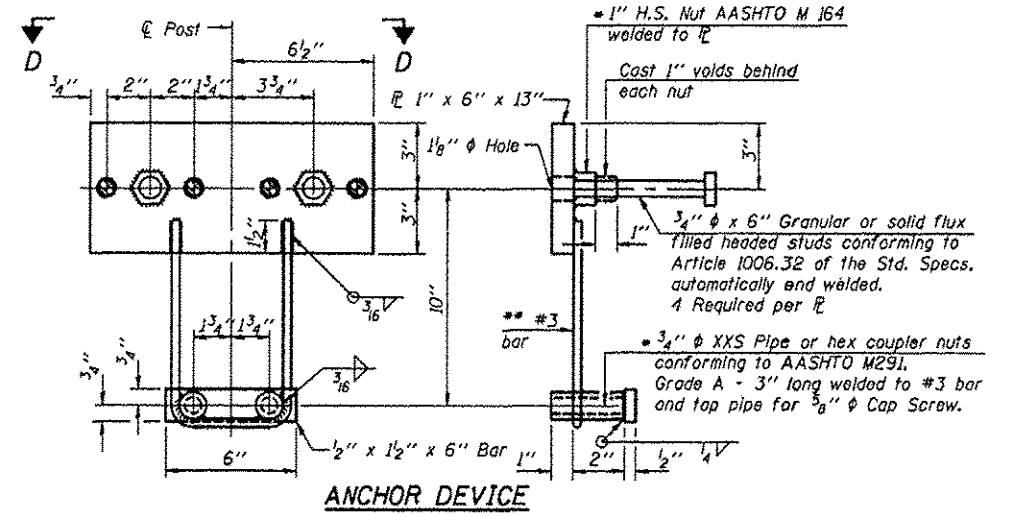

ANCHOR DEVICE

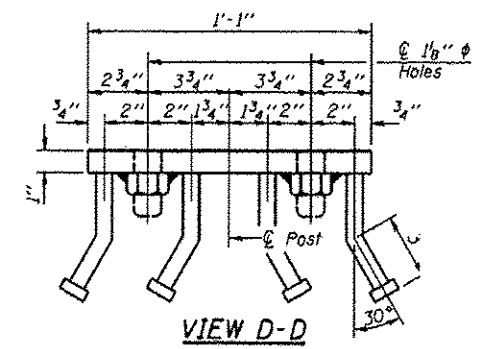

VIEW D-D

- Notes:
- All field drilled holes shall be coated with an approved zinc rich paint before erection.
 - For multi-span bridges, sufficient 1/4" x 6" x 1'-2" galvanized steel shims shall be provided to align rail between adjacent spans. Cost included with Steel Railing, Type S-1.
 - All steel rail elements shall be galvanized according to Article 509.05 of the Standard Specifications.
 - Threaded areas shall be plugged or blocked off during casting of beam.
 - Whenever the lower insert assemblies interfere with strand locations, the #3 bars shall be cut and adjusted in order to allow raising or lowering of the lower inserts. Maximum adjustment not to exceed 1/2".
 - The studs of the anchor devices shall be placed below the top reinforcement bars and the outermost longitudinal reinforcement bar shall be placed directly above the studs of the rail post anchor device.
 - 10'-9" Maximum Post Spacing

BILL OF MATERIAL

Item	Unit	Quantity
Steel Railing, Type S-1	Foot	62

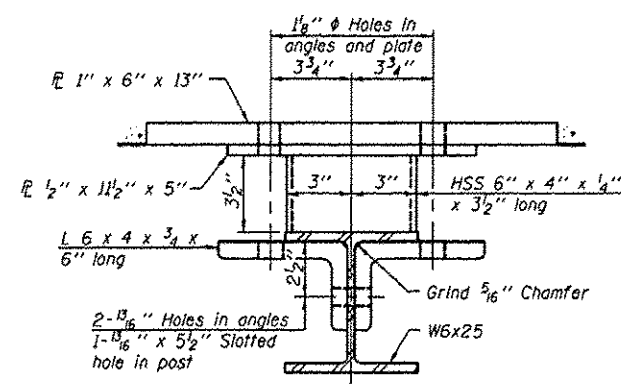

SECTION C-C

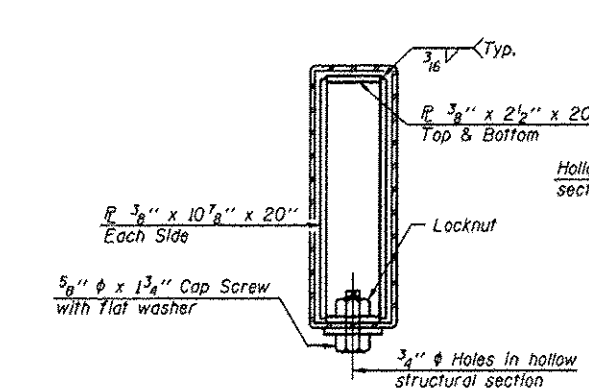

SECTIONS AT RAIL SPLICE

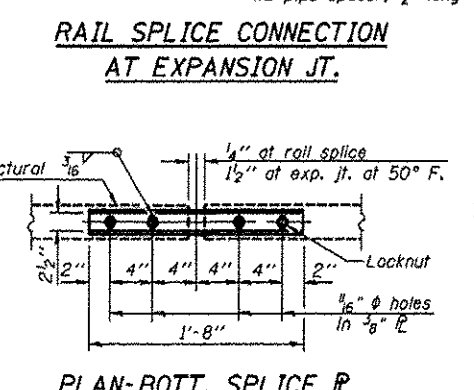

PLAN-BOTT. SPLICE P TYPICAL

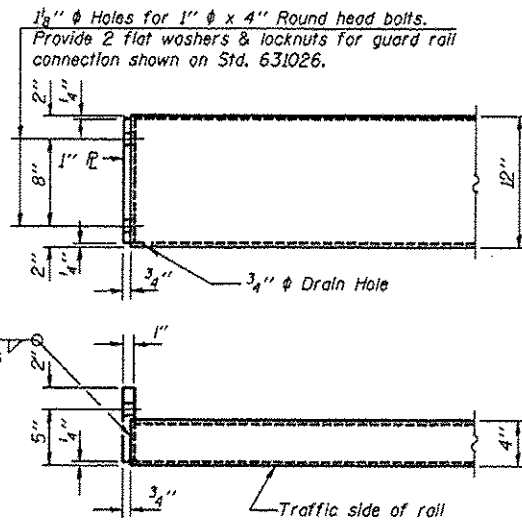

END OF RAIL DETAILS

**STEEL RAILING, TYPE S-1
TOWNSHIP ROUTE 164 (BUTLER ROAD)
BRIER CREEK
SECTION 10-06119-00-BR
SALINE COUNTY
STRUCTURE NO. 083-3241**