

INDEX OF SHEETS

SHEET NO. DESCRIPTION

- 1. COVER SHEET
- 2. SUMMARY OF QUANTITIES AND GENERAL NOTES
- 3. SCHEDULE OF QUANTITIES
- 4. TYPICAL SECTIONS
- 5.-7. PLAN AND PROFILE
- 8. ROADWAY DETAILS
- 9. GUARDRAIL LAYOUT
- 10. SHOULDER LAYOUT
- 11.-33. STATION CROSS SECTIONS
- 34.-48. BRIDGE PLANS
- 49.-54. EXISTING PLANS

HIGHWAY STANDARDS:

- 000001-06 STANDARD SYMBOLS, ABBREVIATIONS, AND PATTERNS
- 280001-07 TEMPORARY EROSION CONTROL SYSTEMS
- 515001-03 NAME PLATE FOR BRIDGES
- 630301-06 SHOULDER WIDENING FOR TYPE 1, (SPECIAL) GUARDRAIL TERMINALS
- 631032-08 TRAFFIC BARRIQR TERMINAL, TYPE 6A
- 635006-03 REFLECTOR AND TERMINAL MARKER PLACEMENT
- 635011-02 REFLECTOR MARKER AND MOUNTING DETAILS
- 701201-04 LANE CLOSURE, 2L, 2W DAY ONLY, FOR SPEEDS ≥ 45 MPH
- 701301-04 LANE CLOSURE, 2L, 2W SHORT TIME OPERATIONS
- 701306-03 LANE CLOSURE, 2L, 2W, SLOW MOVING OPERATIONS DAY ONLY, FOR SPEEDS ≥ 45 MPH
- 701311-03 LANE CLOSURE, 2L, 2W, SLOW MOVING OPERATIONS DAY ONLY
- 701901-02 TRAFFIC CONTROL DEVICES

UTILITIES

EGYPTIAN ELECTRIC CO-OP,
10169 OLD HIGHWAY 3
MURPHYSBORO, IL 62966
ATTN: BROOKE GUTHMAN
618-684-2143

FRONTIER COMMUNICATIONS
208 WEST UNION STREET
MARION, IL 62959
ATTN: TERRY PHILLIPS
618-997-0679

LAKESIDE WATER
3384 DILLINGER ROAD
CARBONDALE, IL 62901
ATTN: ENGINEERING DEPARTMENT
618-457-5547

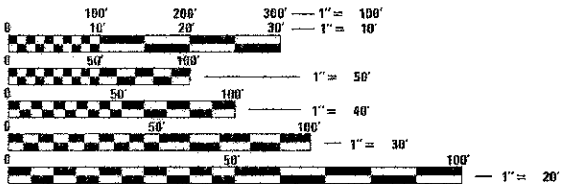

FULL SIZE PLANS HAVE BEEN PREPARED USING STANDARD ENGINEERING SCALES. REDUCED SIZED PLANS WILL NOT CONFORM TO STANDARD SCALES. IN MAKING MEASUREMENTS ON REDUCED PLANS, THE ABOVE SCALES MAY BE USED.

CONTRACT NO. 99509

6-14-13 LETTING ITEM 191

STATE OF ILLINOIS

**DEPARTMENT OF TRANSPORTATION
DIVISION OF HIGHWAYS**

**PLANS FOR PROPOSED
SURFACE TRANSPORTATION PROGRAM
OFF SYSTEM BRIDGE**

**PROJECT BROS-077(047)
SECTION 06-00145-00-BR
JACKSON COUNTY
C.H. 11 / DILLINGER ROAD
EXISTING STRUCTURE NO. 039-3097
C-99-577-06**

ROUTE NO.	SECTION	COUNTY	TOTAL SHEETS	SHEET NO.
C.H. 11	06-00145-00-BR	JACKSON	54	1
FED. ROAD DIST. NO.		ILLINOIS CONTRACT NO. 99509		

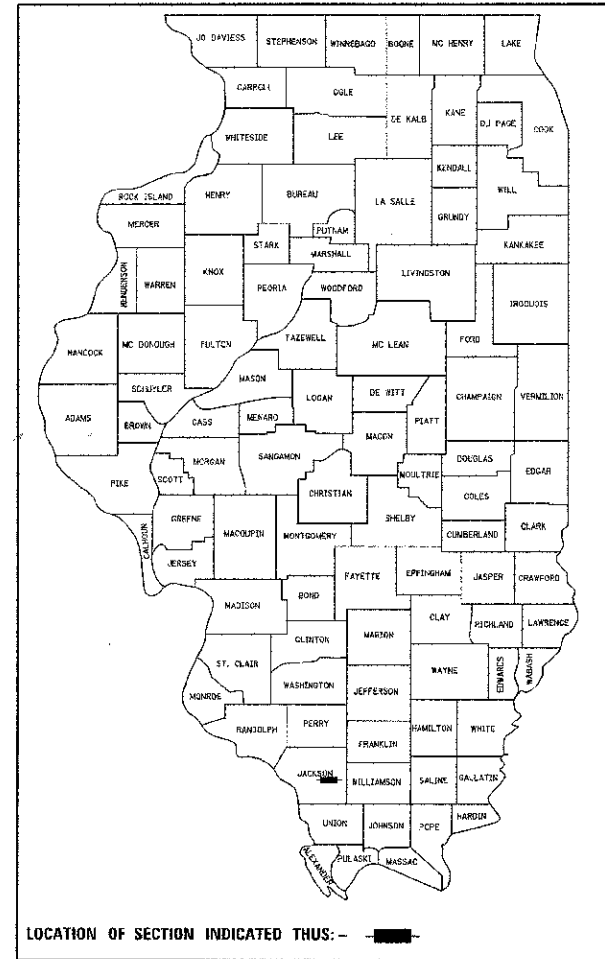

FUNCTIONAL CLASSIFICATION: LOCAL ROAD (NON-URBAN)
DESIGN SPEED: 40 MPH
DESIGN TRAFFIC: 1150 ADT CURRENT

STA. 152+54
PRECAST PRESTRESSED CONCRETE DECK BEAM
SUPERSTRUCTURE, FIVE SPANS @ 56'-11".
27'-0" RDWY.; SKEW = 15°
STRUCTURE NO. 039-3097

IMPROVEMENT BEGINS
STATION 147+75

IMPROVEMENT ENDS
STATION 160+00

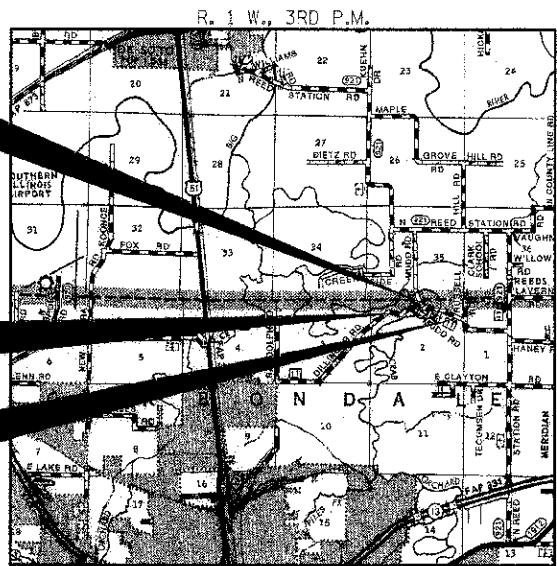

LOCATION MAP

APPROXIMATE SCALE: 0 1 MILE
NET LENGTH OF SECTION = 1225 FEET = 0.23 MILES



ILLINOIS DEPARTMENT OF TRANSPORTATION

APPROVED: *[Signature]* 4/10 20 13
COUNTY ENGINEER

PASSED: *[Signature]* 4/12 20 13
DISTRICT NINE ENGINEER OF LOCAL ROADS & STREETS

Releasing For Bid Based on Limited Review: *[Signature]* April 12 20 13
DEPUTY DIRECTOR OF HIGHWAYS
REGION FIVE ENGINEER
STATE OF ILLINOIS
DEPARTMENT OF TRANSPORTATION

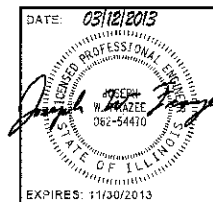

HAMPTON, LENZINI AND RENWICK, INC.
CIVIL ENGINEERS • STRUCTURAL ENGINEERS • LAND SURVEYORS
3085 STEVENSON DRIVE, SUITE 201
SPRINGFIELD, ILLINOIS 62703
217.546.3400 www.hlr-engineering.com

184 000850
ILLINOIS PROFESSIONAL DESIGN FIRM LS / PE / SE CORPORATION

SUMMARY OF QUANTITIES			
CODE NO.	ITEM	UNIT	TOTAL QUANTITY
20100500	TREE REMOVAL, ACRES	ACRE	6.1
20200100	EARTH EXCAVATION	CU YD	1168
20400800	FURNISHED EXCAVATION	CU YD	742
21001000	GEOTECHNICAL FABRIC FOR GROUND STABILIZATION	SQ YD	2630
25100115	MULCH, METHOD 2	ACRE	1.8
25100630	EROSION CONTROL BLANKET	SQ YD	1613
25100900	TURF REINFORCEMENT MAT	SQ YD	156
28000250	TEMPORARY EROSION CONTROL SEEDING	POUND	180
28000305	TEMPORARY DITCH CHECKS	FOOT	61
28000400	PERIMETER EROSION BARRIER	FOOT	1135
28000500	INLET AND PIPE PROTECTION	EACH	1
35100700	AGGREGATE BASE COURSE, TYPE A	TON	1919
40200800	AGGREGATE SURFACE COURSE, TYPE B	TON	18
40600100	BITUMINOUS MATERIALS (PRIME COAT)	GALLON	929
40603080	HOT-MIX ASPHALT BINDER COURSE, IL-19.0, N50	TON	525
40603310	HOT-MIX ASPHALT SURFACE COURSE, MIX "C", N50	TON	313
40203019	HOT-MIX ASPHALT SHOULDERS, 5 1/2"	SQ YD	1188
50101500	REMOVAL OF EXISTING SUPERSTRUCTURES	EACH	1
50102400	CONCRETE REMOVAL	CU YD	6.0
50200100	STRUCTURE EXCAVATION	CU YD	54
50300225	CONCRETE STRUCTURES	CU YD	7.4
50300255	CONCRETE SUPERSTRUCTURE	CU YD	2.6
50400405	PRECAST PRESTRESSED CONCRETE DECK BEAMS (21" DEPTH)	SQ FT	7685
50300205	REINFORCEMENT BARS EPOXY COATED	POUND	1540
50901050	STEEL RAILING, TYPE SM	FOOT	572
51500100	NAME PLATES	EACH	1
52000110	PERFORMED JOINT STRIP SEAL	FOOT	56
54200220	PIPE CULVERTS, CLASS D, TYPE 1 15"	FOOT	26
58100200	WATERPROOFING MEMBRANE SYSTEM	SQ YD	849
58300100	PORTLAND CEMENT MORTAR FAIRING COURSE	FOOT	570
58700300	CONCRETE SEALER	SQ FT	104
59300100	CONTROLLED LOW-STRENGTH MATERIAL	CU YD	14
63000001	STEEL PLATE BEAM GUARDRAIL, TYPE A 6 FOOT POSTS	FOOT	400
63100087	TRAFFIC BARRIER TERMINAL, TYPE 6A	EACH	4
63100167	TRAFFIC BARRIER TERMINAL, TYPE 1 (SPECIAL) TANGENT	EACH	4
67100100	MOBILIZATION	L SUM	1

* SEE SPECIAL PROVISIONS
* SPECIALTY ITEM

SUMMARY OF QUANTITIES			
CODE NO.	ITEM	UNIT	TOTAL QUANTITY
78001110	PAINT PAVEMENT MARKING - LINE 4"	FOOT	4900
78200410	GUARDRAIL MARKERS, TYPE A	EACH	16
78201000	TERMINAL MARKER - DIRECT APPLIED	EACH	4
X2501000	SEEDING, CLASS 2 (SPECIAL)	ACRE	0.90
X2810208	STONE RIPRAP, CLASS A4 (SPECIAL)	TON	610
Z0012754	STRUCTURAL REPAIR OF CONCRETE (DEPTH EQUAL TO OR LESS THAN 5 INCHES)	SQ FT	60
Z0001900	ASBESTOS BEARING PAD REMOVAL	EACH	36

* SEE SPECIAL PROVISIONS
* SPECIALTY ITEM

GENERAL NOTES

- 1) ALL CONSTRUCTION SHALL BE DONE IN ACCORDANCE WITH THE STATE OF ILLINOIS STANDARD SPECIFICATIONS FOR ROAD AND BRIDGE CONSTRUCTION, ADOPTED JANUARY 1, 2012, THESE PLANS, AND THE SPECIAL PROVISIONS INCLUDED IN THE CONTRACT DOCUMENTS.
- 2) ALL CLEARING, GRUBBING, AND REMOVAL OF EXISTING DRAINAGE STRUCTURES SHALL BE INCLUDED IN EARTH EXCAVATION. ALL MATERIAL SHALL BE PROPERLY DISPOSED OF BY THE CONTRACTOR IN A METHOD APPROVED BY THE ENGINEER. PAVEMENT REMOVAL SHALL NOT BE PAID FOR SEPARATELY BUT SHALL BE INCLUDED WITH EARTH EXCAVATION. PROPER DISPOSAL OF BITUMINOUS MATERIAL SHALL BE INCLUDED IN EARTH EXCAVATION AND NO ADDITIONAL COMPENSATION WILL BE ALLOWED.
- 3) THE LOCATION OF EXISTING GAS MAINS, ELECTRIC POWER LINES, TELEPHONE LINES AND OTHER UTILITIES AS SHOWN ON THE PLANS ARE BASED ON CAREFUL FIELD INVESTIGATION AND THE BEST INFORMATION AVAILABLE, BUT THE LOCATIONS ARE NOT GUARANTEED. IT SHALL BE THE CONTRACTORS RESPONSIBILITY TO ASCERTAIN THEIR EXACT LOCATION FROM THE INDIVIDUAL UTILITY COMPANIES AND BY FIELD INSPECTIONS.
- 4) WHERE SECTION OR SUBSECTION MONUMENTS ARE ENCOUNTERED, THE ENGINEER SHALL BE NOTIFIED BEFORE SUCH MONUMENTS ARE REMOVED. THE CONTRACTOR SHALL PROTECT AND CAREFULLY PRESERVE ALL PROPERTY MARKS AND MONUMENTS UNTIL THE OWNER, AN AUTHORIZED SURVEYOR OR AGENT HAS WITNESSED OR OTHERWISE REFERENCED THEIR LOCATION.
- 5) THE FOLLOWING RATES OF APPLICATION HAVE BEEN USED IN CALCULATING PLAN QUANTITIES

HOT MIX ASPHALT	112 LBS/INCH DEPTH/SQ. YD.
AGGREGATE BASE AND SURFACE COURSES	2.05 TON/CU.YD.
BITUMINOUS MATERIALS (PRIME COAT)	0.30 GAL/SQ. YD.
STONE RIPRAP, CLASS A4 (SPECIAL)	1.75 TON/CU.YD.
- 6) THE AREA TO BE SEEDED SHALL CONSIST OF ALL DISTURBED EARTH SURFACES WITHIN THE RIGHT OF WAY OR AS DIRECTED BY THE ENGINEER
SEEDING, CLASS 2 (SPECIAL) = 0.90 ACRES
- 7) EROSION CONTROL BLANKET SHALL BE PLACED ON ALL SLOPES STEEPER THAN 1V:3H AT THE TIME OF PERMANENT SEEDING.
- 8) TREE REMOVAL MAY NOT BE CONDUCTED FROM APRIL 1 TO SEPTEMBER 30. ALL AREAS OF TREE REMOVAL SHALL BE APPROVED AND MEASURED FOR PAYMENT BY THE ENGINEER PRIOR TO DISTURBANCE.

FILE NAME = 128127-eh1-summary.dgn	USER NAME =	DESIGNED - J.W.F.	REVISED -	STATE OF ILLINOIS JACKSON COUNTY HIGHWAY DEPARTMENT	SUMMARY OF QUANTITIES AND GENERAL NOTES C.H. 11 / DILLINGER ROAD	C.H.	SECTION	COUNTY	TOTAL SHEETS	SHEET NO.	
HAMPTON LENZINI AND RENWICK, INC. 3030 S.W. 28TH AVENUE, SUITE 201 MIAMI, FL 33155-4279 ILLINOIS PROFESSIONAL DESIGN FIRM 187 PLY. SE. CORP. 31.602086	FLDT SCALE =	DRAWN - R.D.H.	REVISED -			11	06-0C145-00-BR	JACKSON	54	2	
	FLDT DATE = 4/9/2013	CHECKED - S.W.M.	REVISED -			CONTRACT NO. 99509					
		DATE - 03/12/13	REVISED -			ILLINOIS FED. AID PROJECT					

ROADWAY SCHEDULE							
LOCATION	GEOTECHNICAL FABRIC FOR GROUND STABILIZATION	AGGREGATE BASE COURSE TYPE A	AGGREGATE SURFACE COURSE TYPE B	BITUMINOUS MATERIALS (PRIME COAT)	HOT-MIX ASPHALT BINDER COURSE IL-19.0, N50	HOT-MIX ASPHALT SURFACE COURSE MIX "C", N50	HOT-MIX ASPHALT SHOULDERS 5 1/2"
	21001000	35100100	49200800	40600100	40603080	40603310	48203019
	SQ YD	TON	TON	GAL	TON	TON	SQ YD
DILLINGER ROAD							
STA 147+75 TO STA 151+10.72	939	659		311	187	69	457
STA 151+10.72 TO STA 153+97.28						95	
STA 153+97.28 TO STA 160+00	1691	1185		561	338	124	691
MUDD ROAD		74		57		25	
ENTRANCES			18				40
TOTAL	2630	1919	18	929	525	313	1188

HOT-MIX ASPHALT MIXTURE REQUIREMENTS	
MIXTURE TYPE	AIR VOIDS @NdcS
HOT-MIX ASPHALT SURFACE COURSE, MIX "C", N50	4% @ 50 GYR
HOT-MIX ASPHALT BINDER COURSE, IL-19.0, N50	4% @ 50 GYR

PAVEMENT DESIGN (NON-MECHANISTIC)
DESIGN PERIOD 20 YEARS 2033
STRUCTURAL DESIGN TRAFFIC (SDT) = 1130 (2023)
PV = 1028 SU = 68 MU = 34
ROAD/STREET CLASSIFICATION: CLASS III
PERCENT OF STRUCTURAL DESIGN TRAFFIC IN DESIGN LANE
P = 0.5 S = 0.5 MU = 0.5
TRAFFIC FACTOR ACTUAL TF 0.21 AC TYPE 64-22
MINIMUM TF NA
PG GRADE: BINDER = 64-22 SURFACE = 64-22

GUARDRAIL SCHEDULE					
LOCATION	TRAFFIC BARRIER TERMINAL, TYPE GA	TRAFFIC BARRIER TERMINAL, TYPE 1 (SPECIAL) TANGENT	STEEL PLATE BEAM GUARDRAIL, TYPE A 6 FT POSTS	GUARDRAIL MARKERS, TYPE A	TERMINAL MARKER DIRECT APPLIED
	63100087	63100187	63000001	78200410	78201000
	EACH	EACH	FOOT	EACH	EACH
LT. STA 149+63.95 TO LT. STA 156+32.87	2	2	200	8	2
RT. STA 148+75.00 TO RT. STA 155+43.21	2	2	200	8	2
TOTAL	4	4	400	16	4

EARTHWORK SUMMARY						
LOCATION	EARTH EXCAVATION	SHRINKAGE FACTOR	% USED	EARTH EXCAVATION ADJUSTED FOR SHRINKAGE (25%)	EMBANKMENT REQUIRED	EARTHWORK BALANCE WASTE (+) OR SHORTAGE (-)
	CU YD			CU YD	CU YD	CU YD
STA 147+75 TO STA 151+10.72	365	25.00%	100.00%	289	337	-48
STA 153+97.28 TO STA 160+00	783	25.00%	100.00%	587	1268	-681
ENTRANCE EMBANKMENT					13	-13
TOTAL	1168			876	1616	-742

FURNISHED EXCAVATION 742 CU YD.

PERIMETER EROSION BARRIER 28000400	
LOCATION	FOOT
LT. STA 148+60 TO STA 151+00	240
RT. STA 148+60 TO STA 151+05	260
LT. STA 153+95 TO STA 157+45	400
RT. STA 154+15 TO STA 155+20	105
RT. STA 155+30 TO STA 155+50	130
TOTAL	1135

TEMPORARY DITCH CHECKS 28000305	
LOCATION	FOOT
RT. STA 155+25	9
RT. STA 157+00	13
RT. STA 158+00	13
LT. STA 158+50	13
RT. STA 159+00	13
TOTAL	61

SEEDING SCHEDULE				
LOCATION	MULCH, METHOD 2 *	EROSION CONTROL BLANKET	TEMPORARY EROSION CONTROL SEEDING *	SEEDING CLASS 2 (SPECIAL)
	25100115	25100630	28000250	X2501000
	ACRE	SQ YD	POUND	ACRE
LT. STA 147+75 TO LT. STA 151+10.72	0.20	137	20	0.10
RT. STA 147+75 TO RT. STA 151+10.72	0.34	412	34	0.17
LT. STA 153+97.28 TO LT. STA 160+00	0.66	210	66	0.33
RT. STA 153+97.28 TO RT. STA 160+00	0.60	854	60	0.30
TOTAL	1.80	1613	180	0.90

* 2 APPLICATIONS

TREE REMOVAL, ACRES 20100500	
LOCATION	ACRES
RT. STA 148+73 TO STA 149+47	0.01
LT. STA 154+25 TO STA 156+13	0.05
TOTAL	0.06
USE	0.1

PAINT PAVEMENT MARKING - LINE 4"		
LOCATION	SINGLE WHITE EDGE LINE	DOUBLE YELLOW NO PASSING
	78001110	78001110
	FOOT	FOOT
RT. STA 147+75 TO RT. STA 160+00	1225	
CL STA 147+75 TO CL STA 160+00		2450
LT. STA 147+75 TO LT. STA 160+00	1225	
SUBTOTAL	2450	2450
TOTAL	4900	

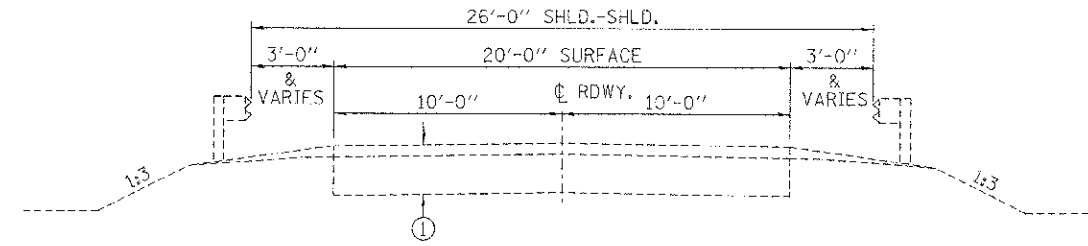

EXISTING TYPICAL SECTION-DILLINGER ROAD
STA. 146+55 TO STA. 158+00

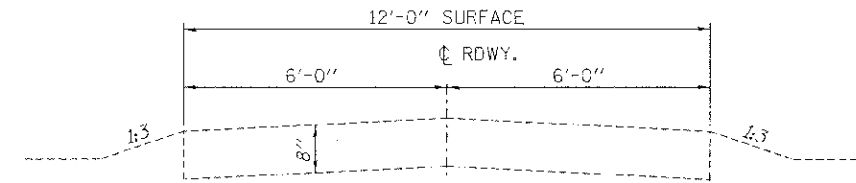

EXISTING TYPICAL CROSS SECTION-MUDD ROAD

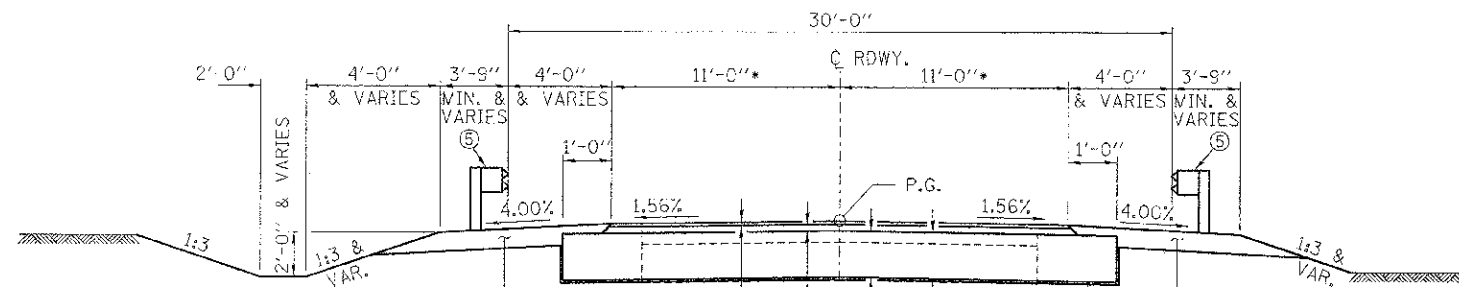

SUGGESTED CUT SECTION
CONSTRUCT AS SHOWN IN
STATION CROSS SECTIONS

PROPOSED TYPICAL CROSS SECTION-DILLINGER ROAD

STA. 149+95 TO STA. 151+10.72
STA. 153+97.28 TO STA. 155+16.53
STA. 158+38.85 TO STA. 160+00*

SUGGESTED FILL SECTION
CONSTRUCT AS SHOWN IN
STATION CROSS SECTIONS

*FROM STA. 159+50 TO STA. 160+00
PAVEMENT TRANSITION FROM EXISTING
WIDTH OF 20' TO PROPOSED WIDTH OF 22'.

**FROM STA. 147+75 TO 149+25
PAVEMENT TRANSITION FROM EXISTING
WIDTH OF 20' TO PROPOSED WIDTH OF 22'
AND TRANSITION FROM EXISTING
PAVEMENT CROSS SLOPE TO FULL SUPER.

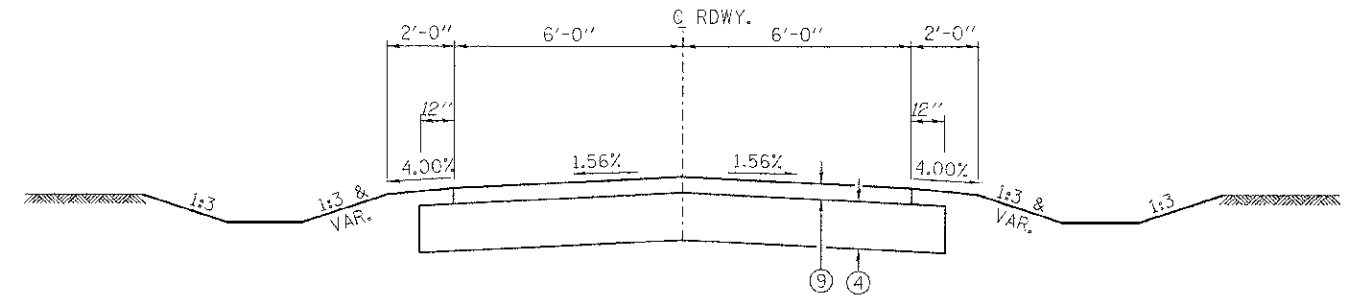

PROPOSED TYPICAL CROSS SECTION-MUDD ROAD

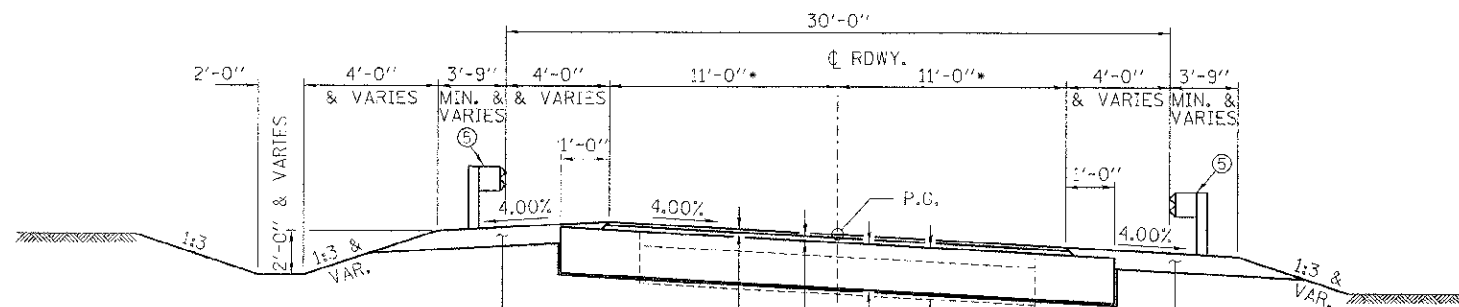

SUGGESTED CUT SECTION
CONSTRUCT AS SHOWN IN
STATION CROSS SECTIONS

PROPOSED TYPICAL CROSS SECTION-DILLINGER ROAD

STA. 147+75 TO STA. 149+95**
STA. 155+16 TO STA. 158+35

SUGGESTED FILL SECTION
CONSTRUCT AS SHOWN IN
STATION CROSS SECTIONS

LEGEND

- ① EXISTING BITUMINOUS TREATED AGGREGATE SURFACE ON AGGREGATE BASE.
- ② HOT-MIX ASPHALT SURFACE COURSE, MIX C, N50 (1 1/2" THICKNESS)
- ③ HOT-MIX ASPHALT BINDER COURSE, IL-19.0, N50 (4" THICKNESS)
- ④ AGGREGATE BASE COURSE, TY A, 8"
- ⑤ STEEL PLATE BEAM GUARD RAIL. SEE SCHEDULE OF QUANTITIES FOR STATIONING
- ⑥ HOT-MIX ASPHALT SHOULDERS, 5 1/2"
- ⑦ GEOTECHNICAL FABRIC FOR GROUND STABILIZATION
- ⑧ AGGREGATE SURFACE COURSE, TY B 6"
- ⑨ HOT-MIX ASPHALT SURFACE COURSE, MIX C, N50 (3" THICKNESS)

FILE NAME = 122127-shc-tye-sta-cm.dgn	USER NAME =	DESIGNED - J.W.F.	REVISED -	STATE OF ILLINOIS JACKSON COUNTY HIGHWAY DEPARTMENT	TYPICAL CROSS SECTIONS C.H. 11 / DILLINGER ROAD		C.H.	SECTION	COUNTY	TOTAL SHEETS	SHEET NO.
HAMPTON, LENZINI AND RENWICK, INC. 3045 STEVENSON DRIVE, SUITE 201 SPRINGFIELD, ILLINOIS 62707	PLOT SCALE =	DRAWN - L.G.C.	REVISED -		11	06-00145-00-BR	JACKSON	54	4		
ILLINOIS PROFESSIONAL DESIGN FIRMA 1811 PEABODY DRIVE, SUITE 100 SPRINGFIELD, ILLINOIS 62707	PLOT DATE = 4/9/2013	CHECKED - S.W.M.	REVISED -		CONTRACT NO. 99509						
		DATE - 03/12/13	REVISED -		SCALE:	SHEET NO. 1 OF 1 SHEETS	STA.	TO STA.		ILLINOIS FED. AID PROJECT	

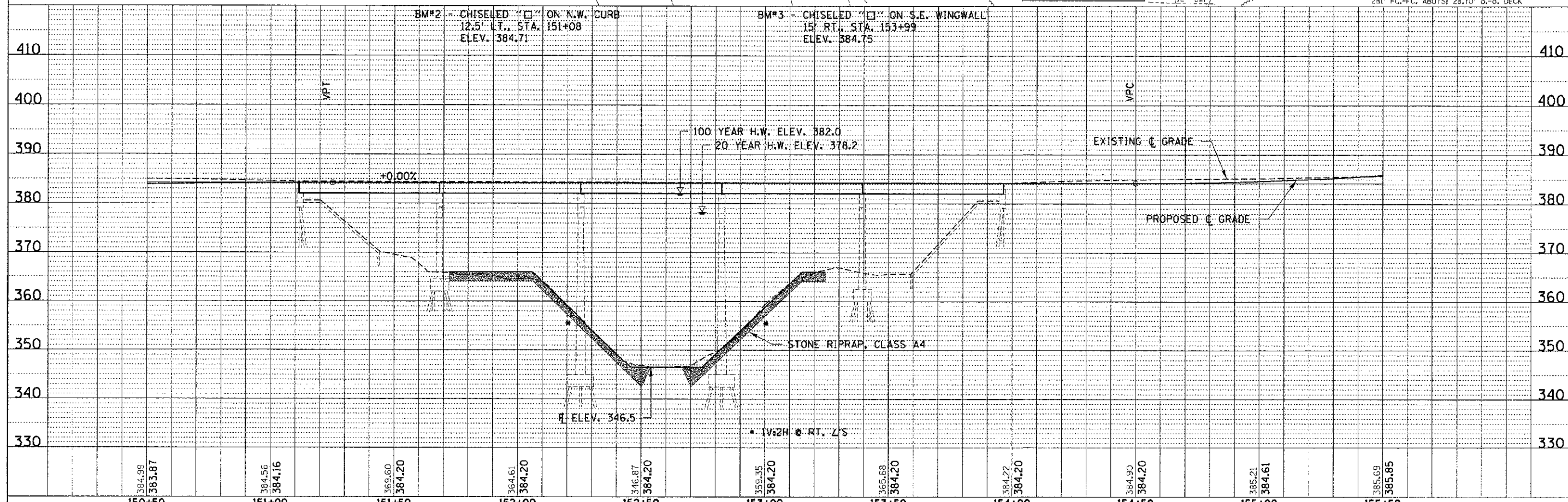
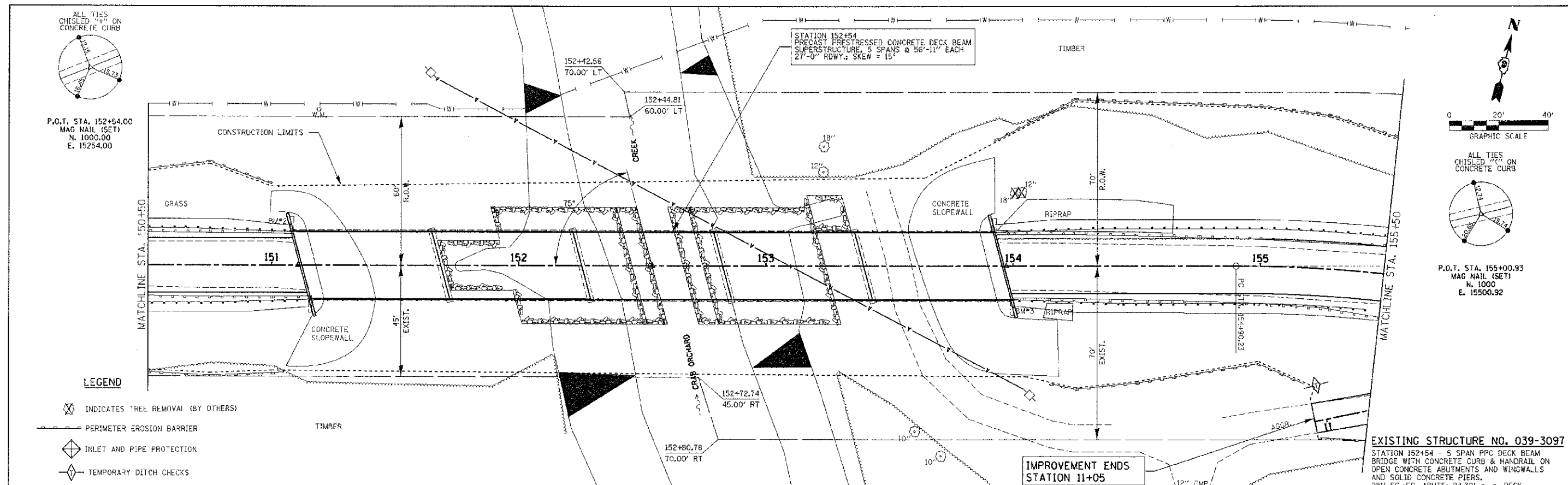

FILE NAME = 120127-shs-pp2.dgn	USER NAME =	DESIGNED - J.W.F.	REVISION -	STATE OF ILLINOIS JACKSON COUNTY HIGHWAY DEPARTMENT	PLAN & PROFILE DILLINGER ROAD	C.H.	SECTION	COUNTY	TOTAL SHEETS	SHEET NO.
HAMPTON, LENZINI AND RENWICK, INC. 3965 STEVENSON DRIVE, SUITE 201 SPRINGFIELD, ILLINOIS 62767	PLCT SCALE =	DRAWN - L.G.C.	REVISION -			11	06-00145-00-BR	JACKSON	54	6
ILLINOIS PROFESSIONAL DESIGN FIRM L.S. # 02-156-00-CP, 100, 100/99	PLCT DATE = 4/9/2013	CHECKED - S.W.M.	REVISION -			CONTRACT NO. 99509			ILLINOIS FED. AID PROJECT	
		DATE - 03/12/13	REVISION -			SCALE: H20V10	SHEET NO. 2 OF 3 SHEETS	STA. 150+50.00 TO STA. 155+50.00		

CURVE 1 SUPERELEVATION TRANSITION DETAIL

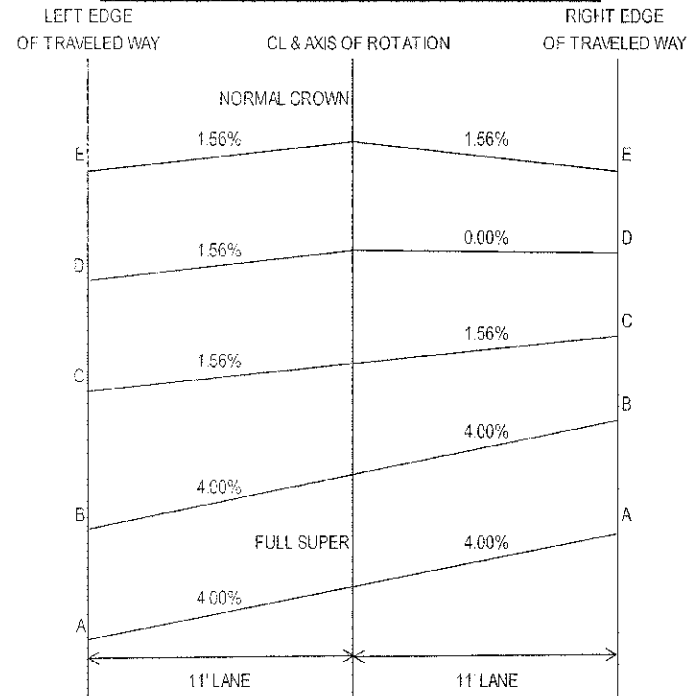

CURVE 2 SUPERELEVATION TRANSITION DETAIL

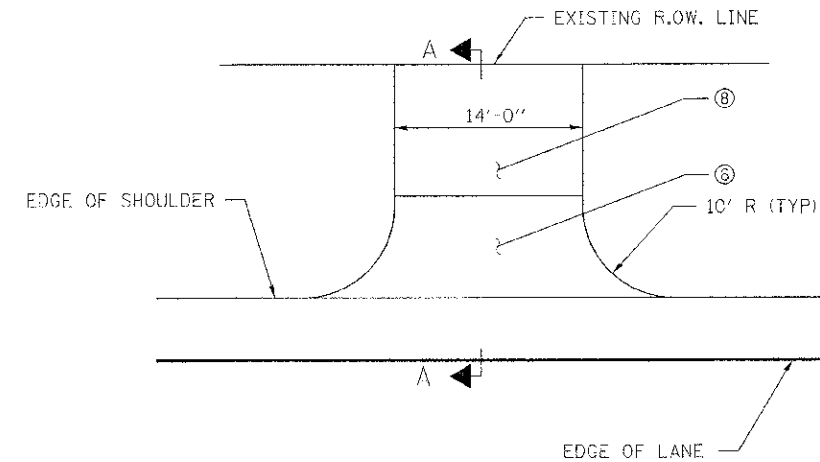
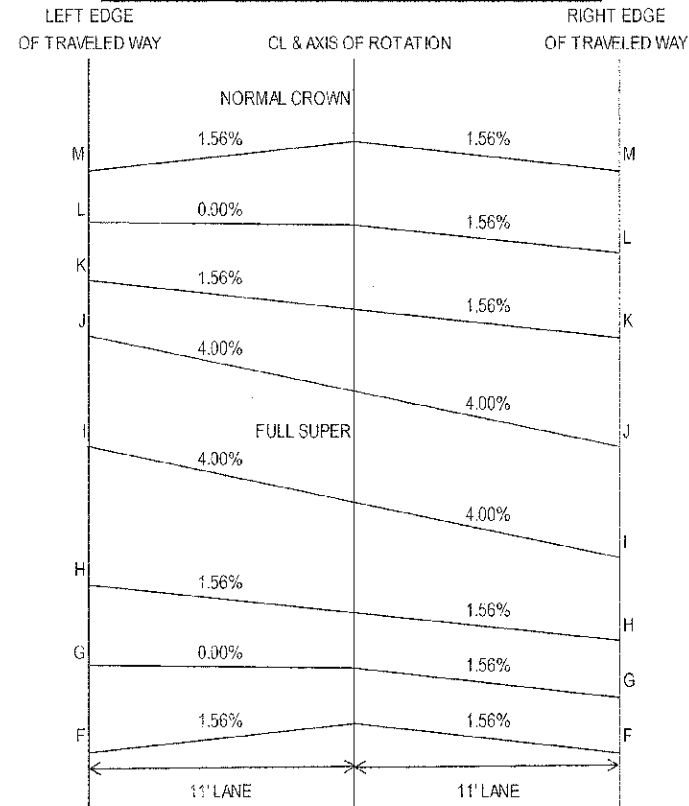

PRIVATE ENTRANCE DETAIL
LT. & RT. STA. 148+24

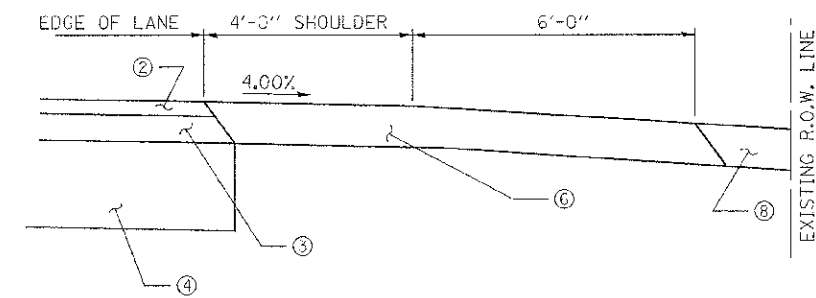

SECTION A-A

LEGEND

- ① EXISTING BITUMINOUS TREATED AGGREGATE SURFACE ON AGGREGATE BASE.
- ② HOT-MIX ASPHALT SURFACE COURSE, MIX C, N50 (1 1/2" THICKNESS)
- ③ HOT-MIX ASPHALT BINDER COURSE, IL-19.0, N50 (4" THICKNESS)
- ④ AGGREGATE BASE COURSE, TY A, 8"
- ⑤ STEEL PLATE BEAM GUARD RAIL. SEE SCHEDULE OF QUANTITIES FOR STATICING
- ⑥ HOT-MIX ASPHALT SHOULDERS, 5 1/2"
- ⑦ GEOTECHNICAL FABRIC FOR GROUND STABILIZATION
- ⑧ AGGREGATE SURFACE COURSE, TY B 6"
- ⑨ HOT-MIX ASPHALT SURFACE COURSE, MIX C, N50 (3" THICKNESS)

CURVE 1 SUPERELEVATION TRANSITION

LOCATION	STATION	CROSS SLOPE	
		LEFT	RIGHT
A	148+25.00	-4.00%	4.00%
B	149+95.00	-4.00%	4.00%
C	150+41.17	-1.56%	1.56%
D	150+70.68	-1.56%	0.00%
E	151+00.20	-1.56%	-1.56%

CURVE 2 SUPERELEVATION TRANSITION

LOCATION	STATION	CROSS SLOPE	
		LEFT	RIGHT
F	154+11.33	-1.56%	-1.56%
G	154+40.85	0.00%	-1.56%
H	154+70.36	1.56%	-1.56%
I	155+16.53	4.00%	-4.00%
FULL SUPER			
J	158+38.85	4.00%	-4.00%
K	158+85.02	1.56%	-1.56%
L	159+14.53	0.00%	-1.56%
M	159+44.05	-1.56%	-1.56%

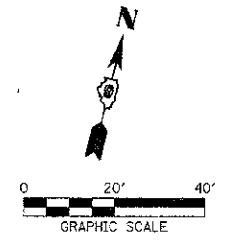
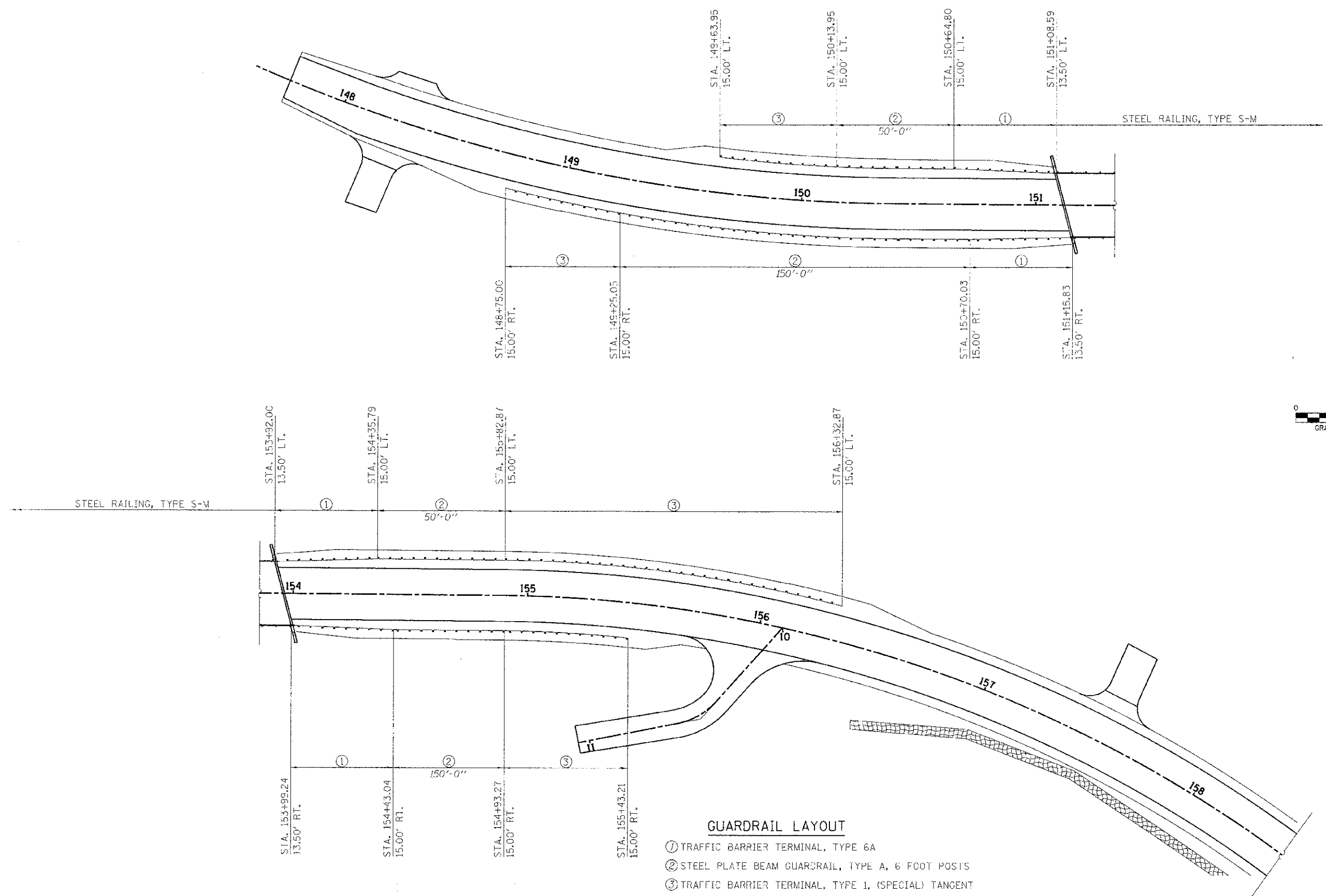

GUARDRAIL LAYOUT

- ① TRAFFIC BARRIER TERMINAL, TYPE 6A
- ② STEEL PLATE BEAM GUARDRAIL, TYPE A, 6 FOOT POSTS
- ③ TRAFFIC BARRIER TERMINAL, TYPE 1, (SPECIAL) TANGENT

FILE NAME = 120127-shr-g-ar01.dgn	USER NAME =	DESIGNED - J.W.F.	REVISED -	STATE OF ILLINOIS JACKSON COUNTY HIGHWAY DEPARTMENT	GUARDRAIL LAYOUT DILLINGER ROAD	C.H.	SECTION	COUNTY	TOTAL SHEETS	SHEET NO.	
HAMPTON, LENZINI AND RENWICK, INC. 3835 STEUBEN AVENUE SUITE 201 SPRINGFIELD, ILLINOIS 62776	PLOT SCALE =	DRAWN - R.D.H.	REVISED -			11	06-00145-00-BR	JACKSON	54	9	
ILLINOIS PROFESSIONAL DESIGN FIRM 1217 E. IRE COMPANY	PLOT DATE = 4/9/2013	CHECKED - S.W.M.	REVISED -			CONTRACT NO. 99509					
		DATE - 03/12/13	REVISED -			ILLINOIS FED. AID PROJECT					

SCALE: SHEET NO. 1 OF 1 SHEETS STA. TO STA.

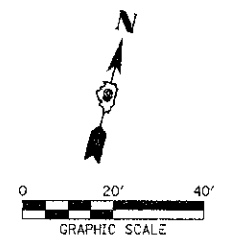
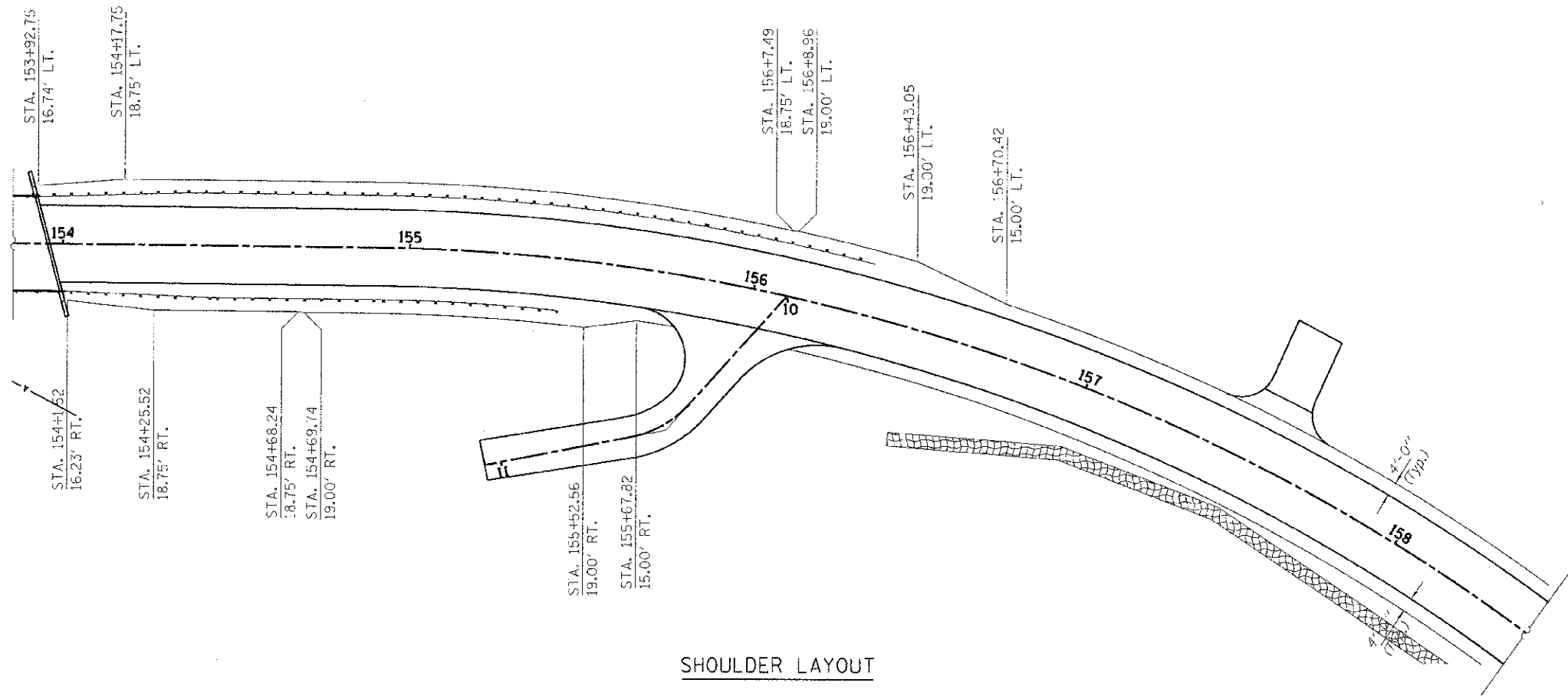
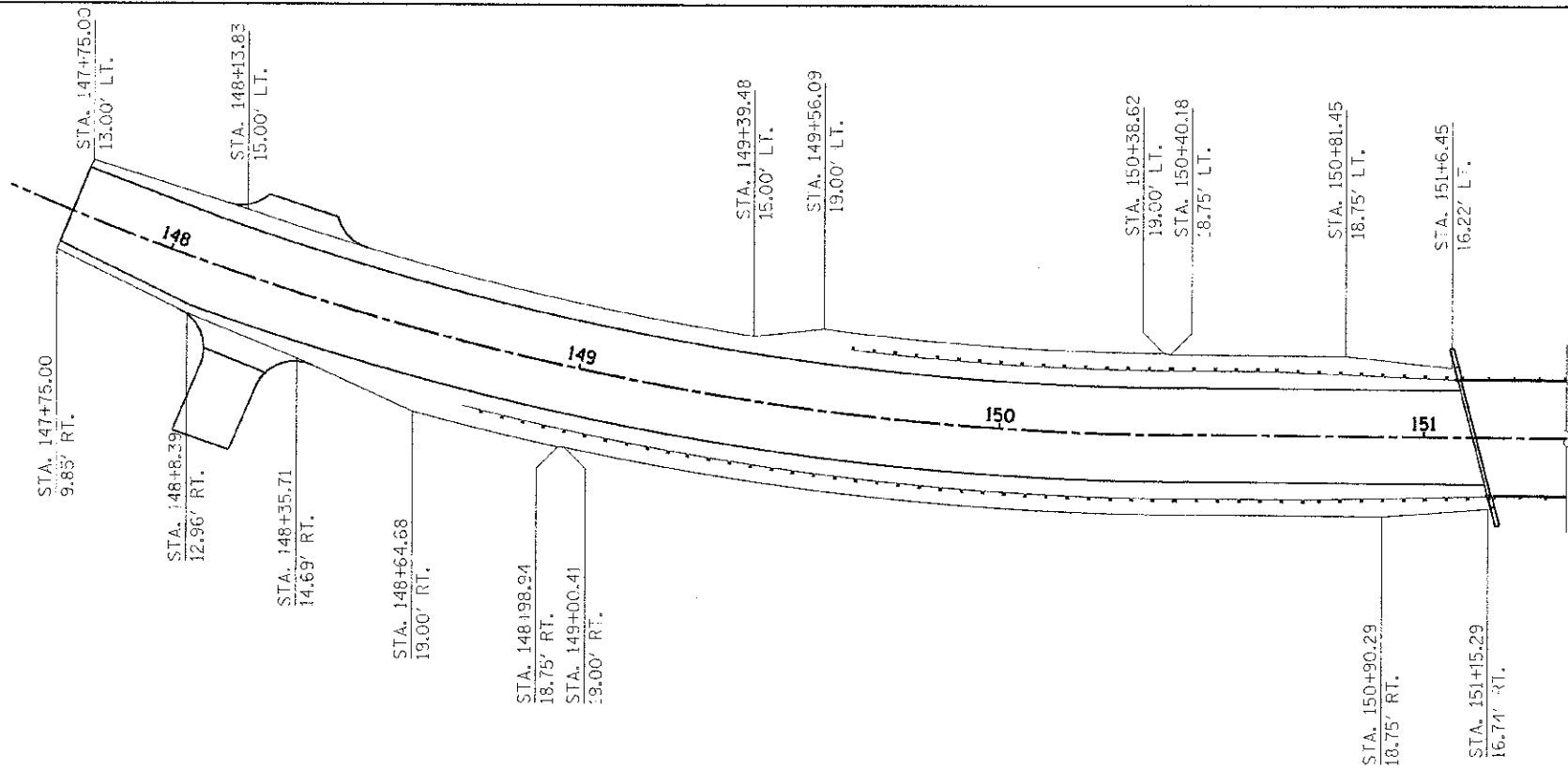

SHOULDER LAYOUT

FILE NAME = 120127-ent-shoulder.dgn	USER NAME =	DESIGNED - J.W.F.	REVISED -	STATE OF ILLINOIS JACKSON COUNTY HIGHWAY DEPARTMENT	SHOULDER LAYOUT DILLINGER ROAD		C.H.	SECTION	COUNTY	TOTAL SHEETS	SHEET NO.
HAMPTON, LENZINI AND RENWICK, INC. 300 STEVENSON DRIVE, SUITE 201 SPRINGFIELD, ILLINOIS 62782 ILLINOIS PROFESSIONAL DESIGN FIRM 17/PL/22/CCRP 131.000739	PLDT SCALE =	DRAWN - R.D.H.	REVISED -		11	05-00145-00-BR	JACKSON	54	10	CONTRACT NO. 99509	
PLDT DATE = 4/9/2013	DATE = 03/12/13	CHECKED - S.W.M.	REVISED -		SCALE:	SHEET NO. 1 OF 1 SHEETS	STA.	TO STA.	ILLINOIS FED. AID PROJECT		
		DATE = 03/12/13	REVISED -								

BY	DATE
REVIEWED	
DATE	
NOTE BOOK	
AREAS	
CHECKED	

BY	DATE
REVIEWED	
DATE	
NOTE BOOK	
AREAS	
CHECKED	

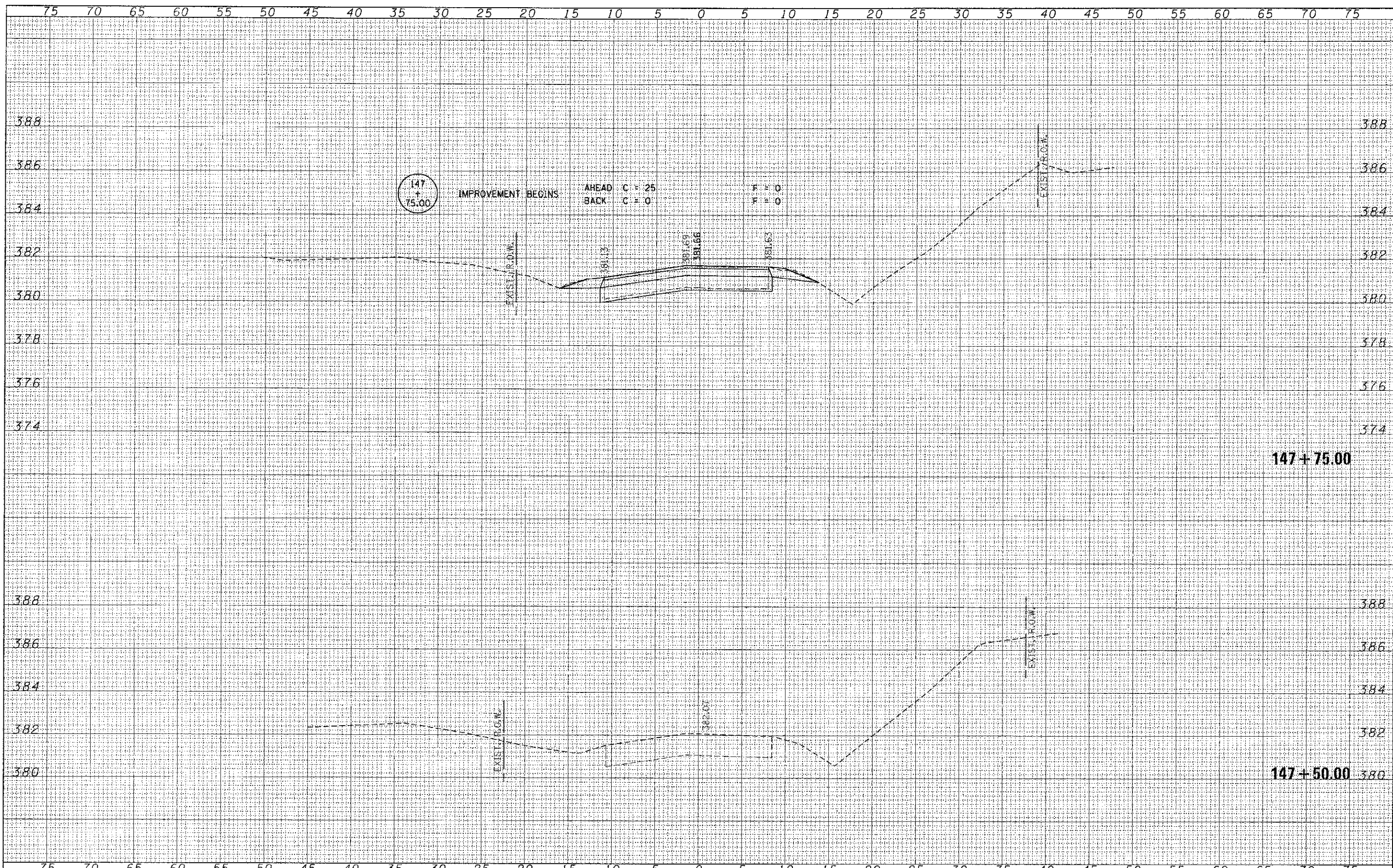

FILE NAME = 120127-ht-xxx.dgn
 HAMPTON, LENZINI AND REHWICK, INC.
 3665 STATE STREET, SUITE 201
 SPRINGFIELD, ILLINOIS 62761
 ILLINOIS PROFESSIONAL DECISION FIRM
 LICENSE NO. 041-000000

USER NAME =
 PLOT SCALE =
 PLOT DATE = 4/9/2013

DESIGNED -	J.W.F.	REVISED -
DRAWN -	L.G.C.	REVISED -
CHECKED -	S.W.M.	REVISED -
DATE -	04/04/13	REVISED -

STATE OF ILLINOIS
 JACKSON COUNTY HIGHWAY DEPARTMENT

STATION CROSS SECTIONS
 DILLINGER ROAD
 SCALE: V5:H2
 SHEET NO. 1 OF 19 SHEETS
 STA. 147+50.00 TO STA. 147+75.00

C.H.	SECTION	COUNTY	TOTAL SHEETS	SHEET NO.
11	06-00145-00-BR	JACKSON	54	11
CARBONDALE ROAD DISTRICT			CONTRACT NO. 99509	
ILLINOIS FED. AID PROJECT				

DATE	
BY	
FINAL SURVEY	
PLOTTED	
NOTE BOOK	
AREAS CHECKED	
NO.	

DATE	
BY	
ORIGINAL SURVEY	
PLOTTED	
NOTE BOOK	
AREAS CHECKED	
NO.	

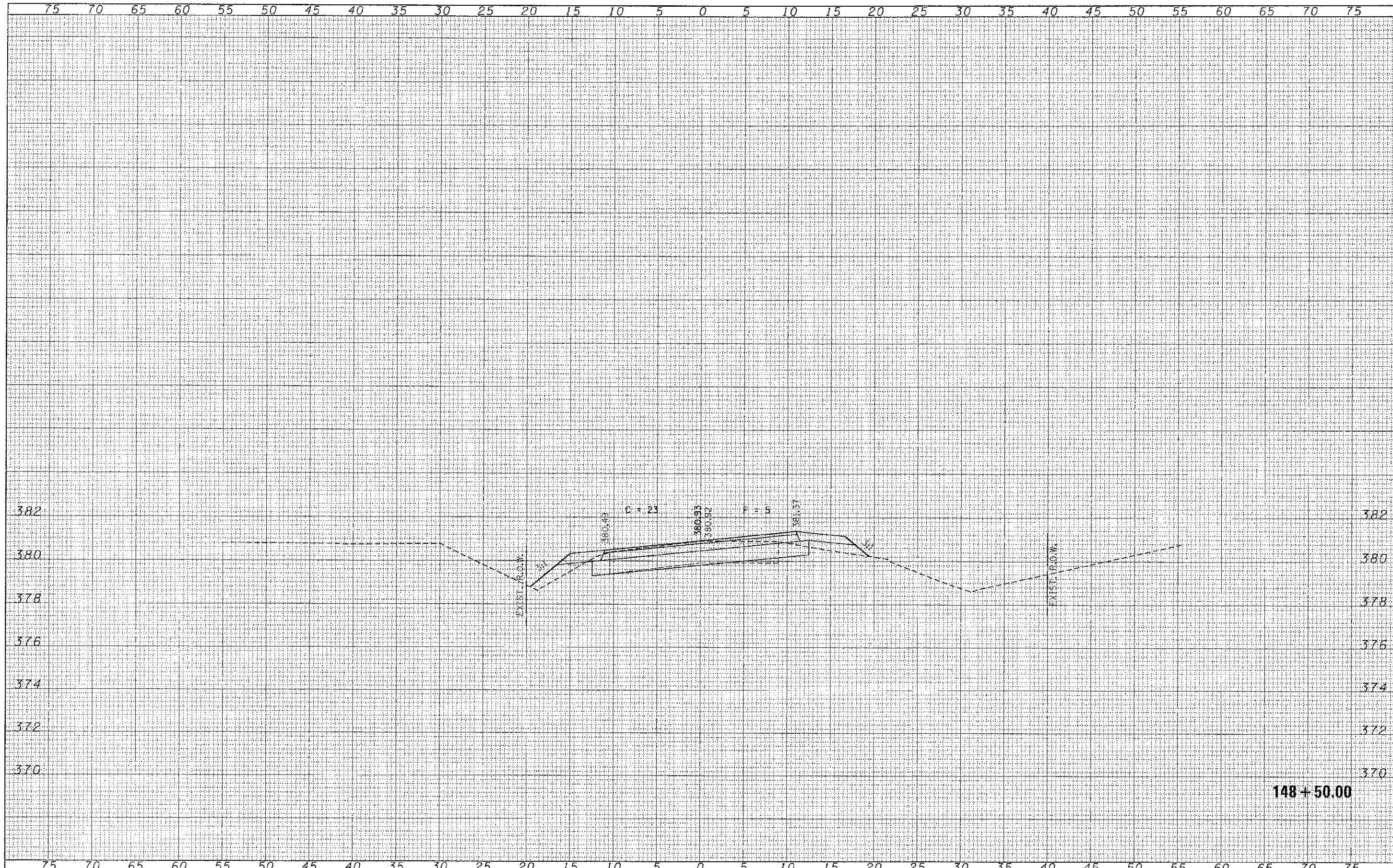

FILE NAME = 1220127-ah1-xxx.dgn
 HAMPTON, LENZINI AND RENWICK, INC.
 300 STEVENSON DRIVE, SUITE 200
 SPRINGFIELD, ILLINOIS 62761
 ILLINOIS PROFESSIONAL ENGINEERING FIRM
 LICENSE NO. 040080

USER NAME
 PLOT SCALE
 PLOT DATE = 4/9/2013

DESIGNED - J.W.F.
 DRAWN - L.G.C.
 CHECKED - S.W.M.
 DATE - 04/04/13

REVISED -
 REVISED -
 REVISED -
 REVISED -

STATE OF ILLINOIS
 JACKSON COUNTY HIGHWAY DEPARTMENT

STATION CROSS SECTIONS
 DILLINGER ROAD
 SCALE: V5:H2
 SHEET NO. OF SHEETS STA. 148+50.00 TO STA. 148+50.00

C.H.	SECTION	COUNTY	TOTAL SHEETS	SHEET NO.
11	06-00145-00-6R	JACKSON	54	14
CARBONDALE ROAD DISTRICT			CONTRACT NO. 99509	
ILLINOIS FED. AID PROJECT				

FINAL SURVEY	SUBMITTED	DATE
NOTE BOOK	PLOTTED	
NO.	TEMPLATE	
	AREAS	
	DESIGNED	

ORIGINAL SURVEY	SUBMITTED	DATE
NOTE BOOK	PLOTTED	
NO.	TEMPLATE	
	AREAS	
	DESIGNED	

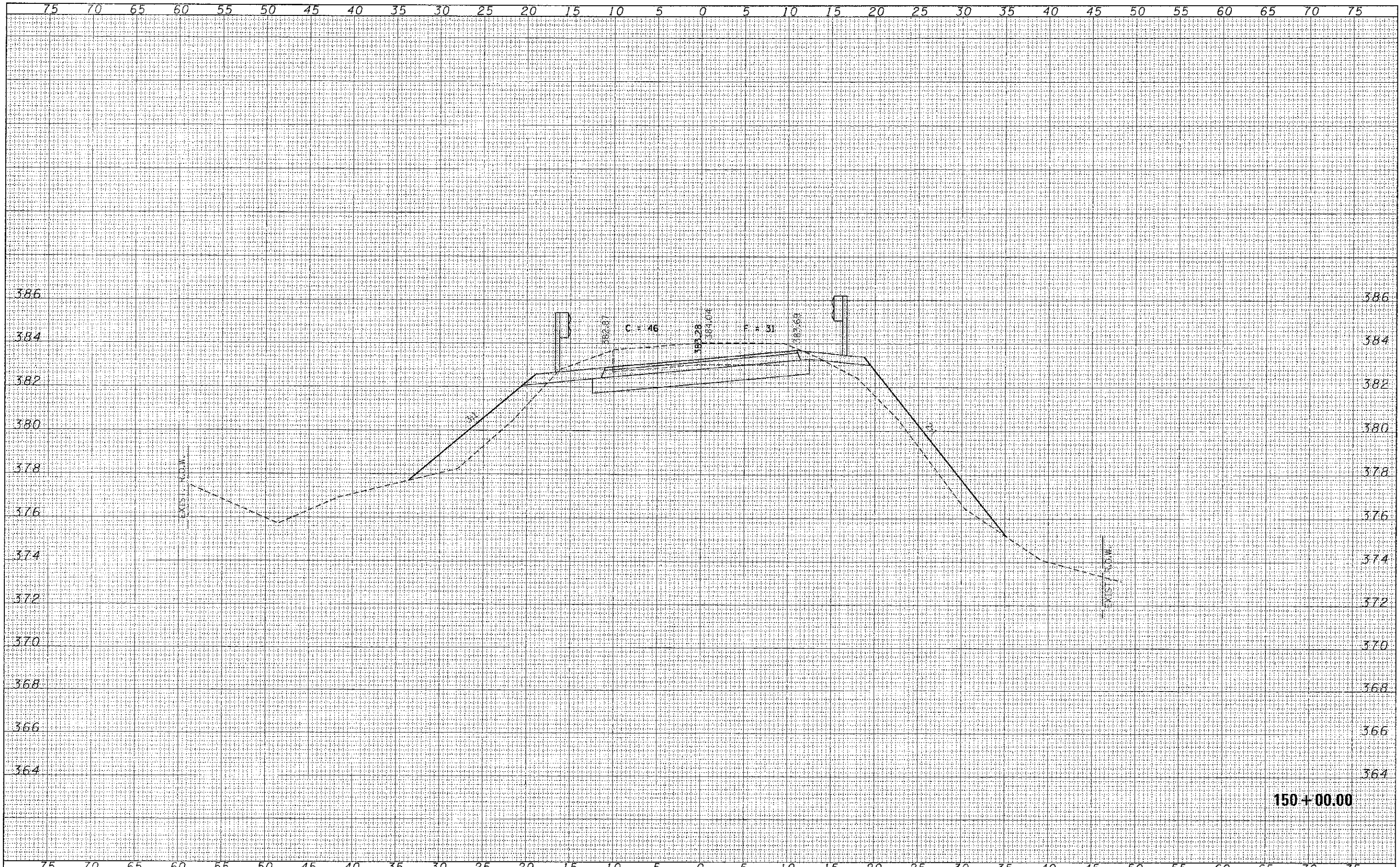

150+00.00

FILE NAME = 120127-hnt-exe.dgn	USER NAME =	DESIGNED - J.W.F.	REVISED -	STATE OF ILLINOIS JACKSON COUNTY HIGHWAY DEPARTMENT	STATION CROSS SECTIONS DILLINGER ROAD			C.H.	SECTION	COUNTY	TOTAL SHEETS
HLR HAMPSON, LENZINI AND RENWICK, INC. 304 STEVENSON DRIVE, SUITE 201 SPRINGFIELD, ILLINOIS 62761 ILLINOIS PROFESSIONAL DESIGN FIRM LIC # 019-103-0700P INC-000001	PLOT SCALE =	CHECKED - S.W.M.	REVISED -		11	06-00145-00-BR	JACKSON	54			
	PLOT DATE = 4/9/2013	DATE - 04/04/13	REVISED -		CARBONDALE ROAD DISTRICT			CONTRACT NO. 99509			
					ILLINOIS FED. AID PROJECT						

DATE	
BY	
FINAL SURVEY	SUBMITTED
NOTE BOOK	PLOTTED
NO.	AREAS CHECKED

DATE	
BY	
ORIGINAL SURVEY	REVIEWED
NOTE BOOK	PLOTTED
NO.	AREAS CHECKED

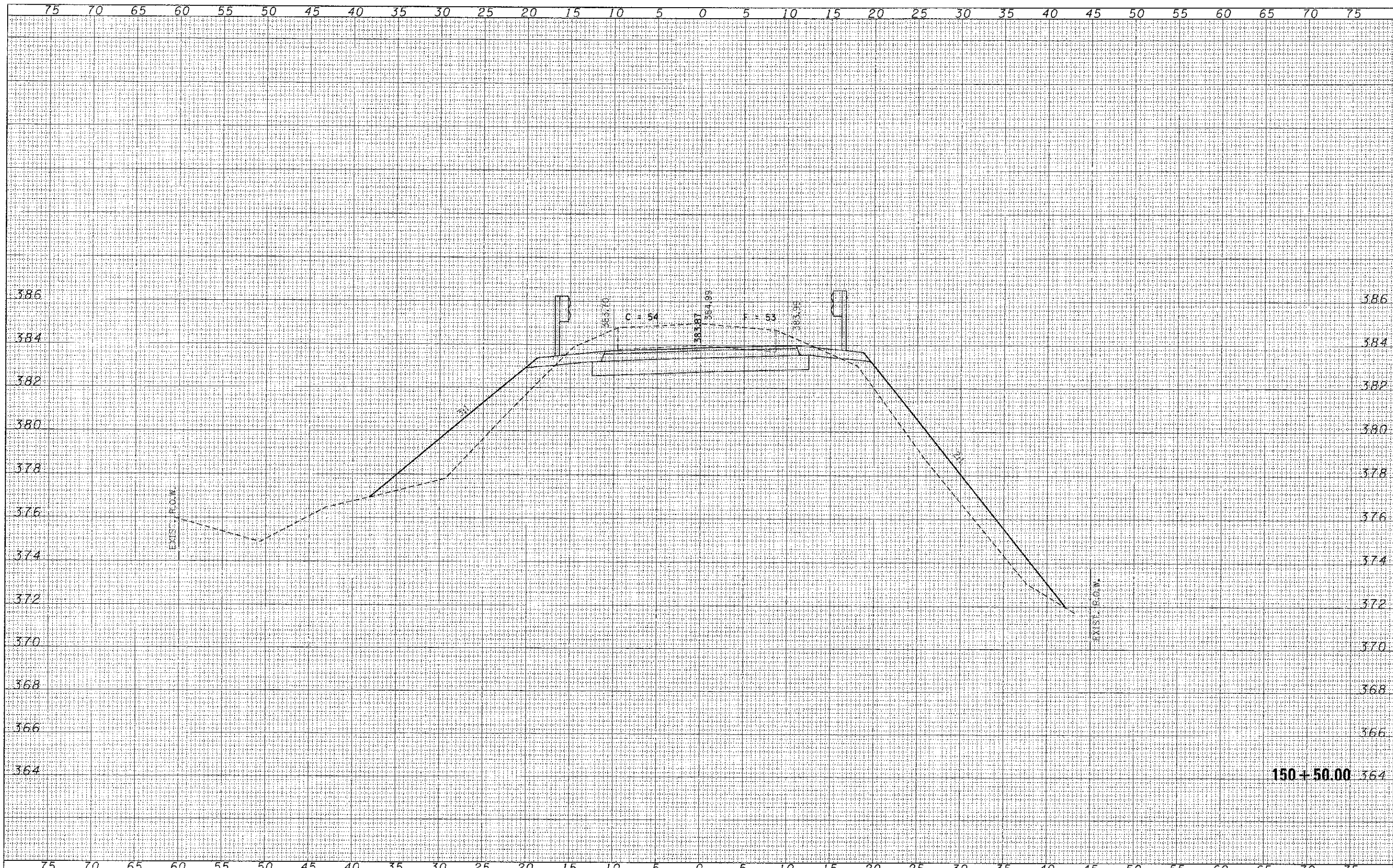

FILE NAME = 120127-shr-ans.dgn	USER NAME =	DESIGNED - J.W.F.	REVISIONS -	STATE OF ILLINOIS JACKSON COUNTY HIGHWAY DEPARTMENT	STATION CROSS SECTIONS DILLINGER ROAD				
HAMPTON, LENZINI AND RENWICK, INC.		DRAWN - L.G.C.	REVISIONS -		C.H.	SECTION	COUNTY	TOTAL SHEETS	SHEET NO.
7845 STEVENSON DRIVE, SUITE 201 SPRINGFIELD, ILLINOIS 62767		CHECKED - S.W.M.	REVISIONS -		11	06-00145-00-BR	JACKSON	54	18
ILLINOIS PROFESSIONAL DESIGNER L.E. # 041-000000		DATE - 04/04/13	REVISIONS -		CARBONDALE ROAD DISTRICT		CONTRACT NO. 99509	ILLINOIS FED. AID PROJECT	

SCALE: V5#2 SHEET NO. OF SHEETS STA. 150+50.00 TO STA. 150+50.00

DATE	
BY	
DESIGNED	
DRAWN	
CHECKED	
DATE	

DATE	
BY	
DESIGNED	
DRAWN	
CHECKED	
DATE	

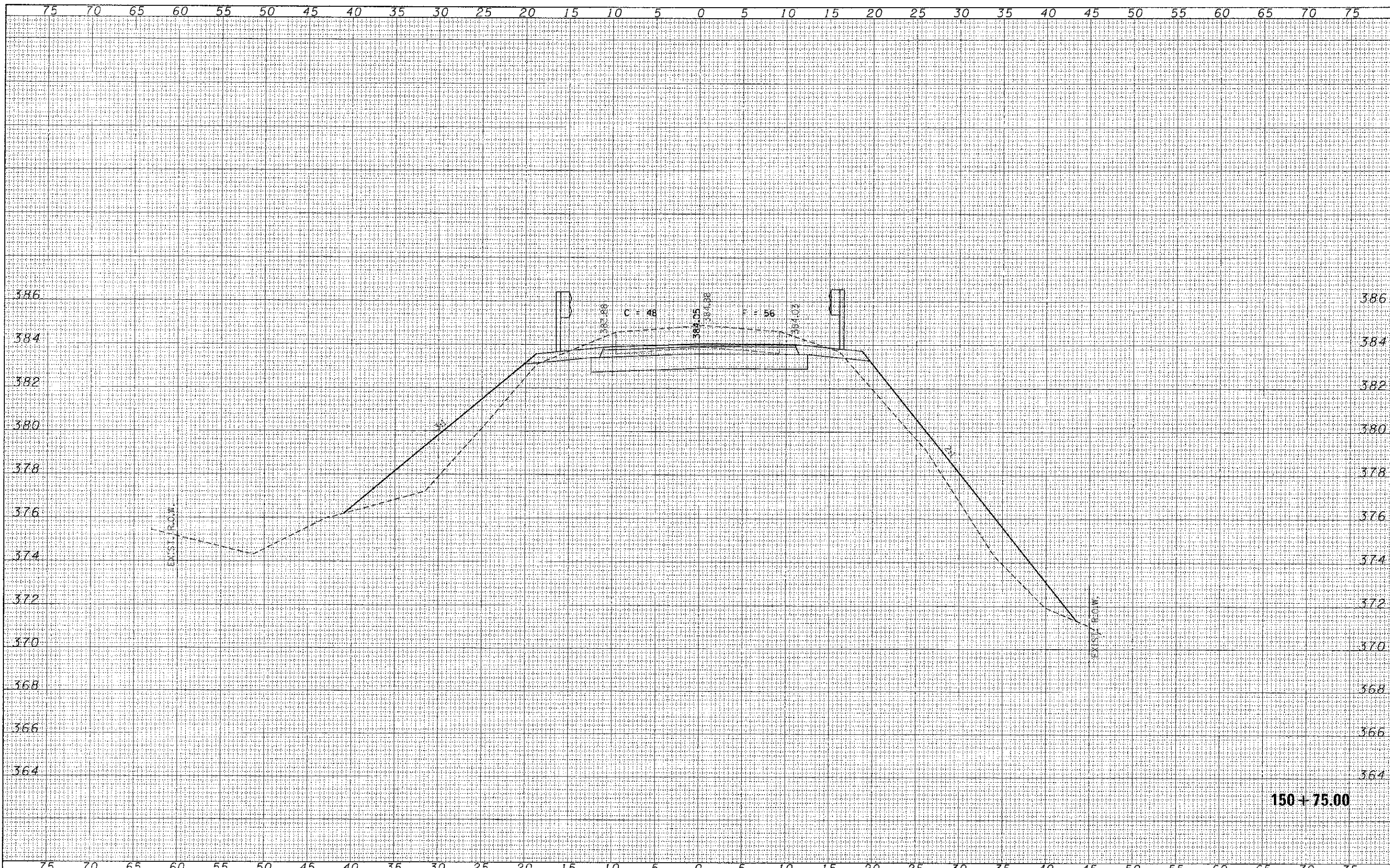

150+75.00

FILE NAME = 120127-shbnae.dgn	USER NAME =	DESIGNED - J.W.F.	REVISIONS -	<p align="center">STATE OF ILLINOIS JACKSON COUNTY HIGHWAY DEPARTMENT</p> <p align="center">STATION CROSS SECTIONS DILLINGER ROAD</p> <p>SCALE: V5/H2 SHEET NO. OF SHEETS STA. 150+75.00 TO STA. 150+75.00</p>	C.H.	SECTION	COUNTY	TOTAL SHEETS	SHEET NO.
HAMPTON, LENZINI AND RENWICK, INC. 3835 BREWERSON DRIVE, SUITE 231 SPRINGFIELD, ILLINOIS 62776	PLOT SCALE =	DRAWN - L.G.C.	REVISIONS -		11	06-00145-00-BR	JACKSON	54	19
ELVIS & ASSOCIATES, INC. 147 W. 1ST ST. ST. LOUIS, MO 63102	PLOT DATE = 4/9/2013	CHECKED - S.W.M.	REVISIONS -		CARBONDALE ROAD DISTRICT		CONTRACT NO. 99509		
		DATE - 04/04/13	REVISIONS -		ILLINOIS FED. AID PROJECT				

FINAL SURVEY	SURVEYED	DATE
NOTE BOOK	PLOTTED	
NO.	AREAS	
	CHECKED	

ORIGINAL SURVEY	SURVEYED	DATE
NOTE BOOK	PLOTTED	
NO.	AREAS	
	CHECKED	

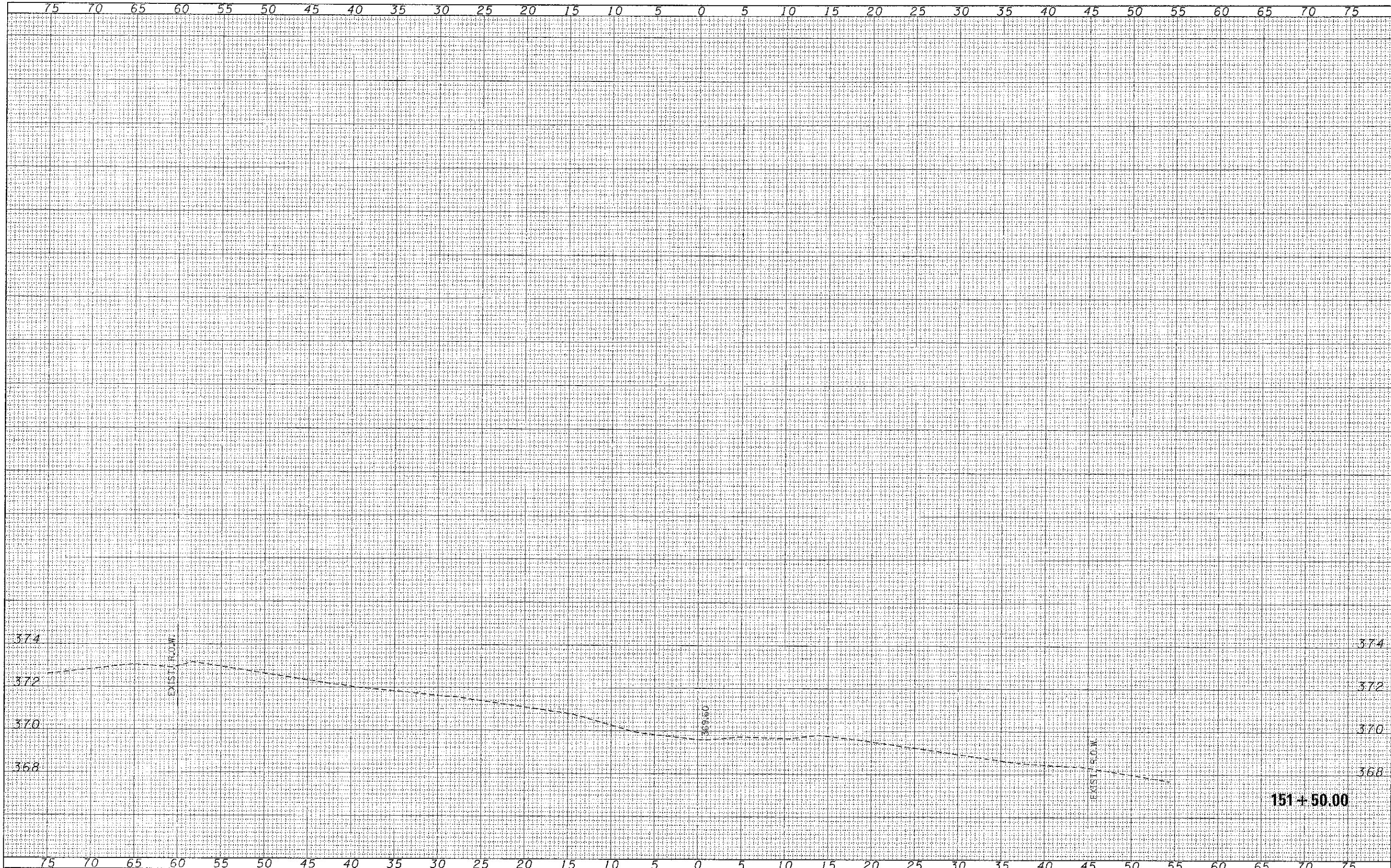

FILE NAME = 120127-shr-ava.dgn	USER NAME =	DESIGNED - J.W.F.	REVISED -	STATE OF ILLINOIS JACKSON COUNTY HIGHWAY DEPARTMENT	STATION CROSS SECTIONS DILLINGER ROAD		C.H.	SECTION	COUNTY	TOTAL SHEETS	SHEET NO.
HAMPTON, LENZINI AND RENWICK, INC.		DRAWN - L.G.C.	REVISED -		11	06-00145-00-BR	JACKSON	54	21		
ILLINOIS PROFESSIONAL DESIGN FIRM		CHECKED - S.W.M.	REVISED -		CARBONDALE ROAD DISTRICT		CONTRACT NO. 99509				
PLT DATE = 4/9/2213		DATE - 04/04/13	REVISED -		SCALE: V5:H2	SHEET NO. CF SHEETS	STA. 151+50.00 TO STA. 151+50.00	ILLINOIS FED. AID PROJECT			

DATE	
BY	
FINAL SURVEY	
SURVEY PLOTTED	
NOTE BOOK	
AREAS CHECKED	

DATE	
BY	
ORIGINAL SURVEY	
SURVEY PLOTTED	
NOTE BOOK	
AREAS CHECKED	

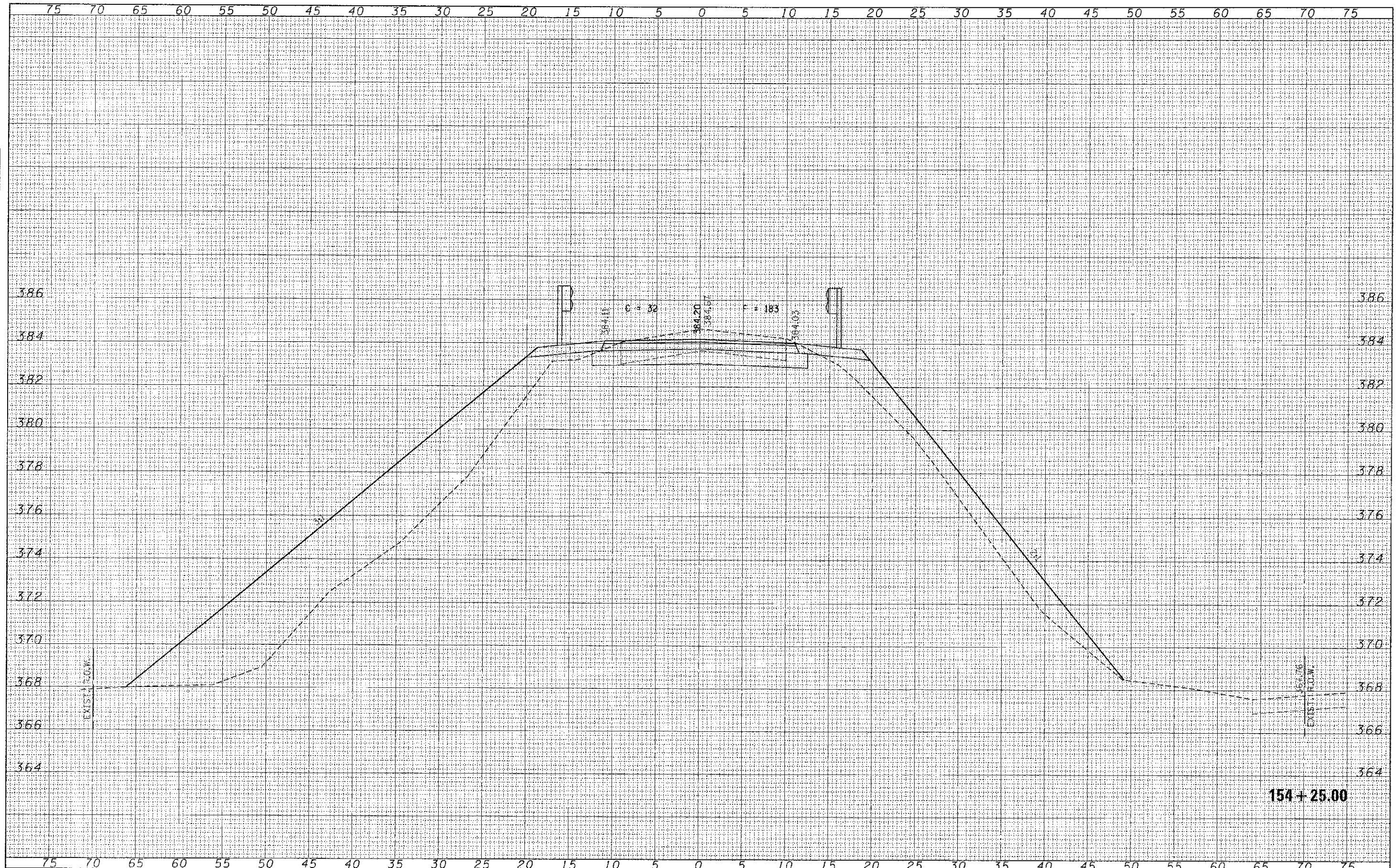

154+25.00

FILE NAME = 120.27-ah-ovaudn	USER NAME =	DESIGNED - J.W.F.	REVISED -	STATE OF ILLINOIS JACKSON COUNTY HIGHWAY DEPARTMENT	STATION CROSS SECTIONS DILLINGER ROAD				C.H.	SECTION	COUNTY	TOTAL SHEETS	SHEET NO.
HAMPTON, LENZINI AND RENWICK, INC.		DRAWN - L.C.C.	REVISED -		II	06-00145-00-BR	JACKSON	54	23				
388 STEVENSON DRIVE SUITE 201 SPRINGFIELD, ILLINOIS 62701		CHECKED - S.W.M.	REVISED -		CARBONDALE ROAD DISTRICT				CONTRACT NO. 99509				
ILLINOIS PROFESSIONAL ENGINEERS 161 PE / 35.073% 184 (2009)		DATE - 04/04/13	REVISED -		SCALE: V5H2	SHEET NO.	OF SHEETS	STA. 154+25.00	TO STA. 154+25.00	ILLINOIS FED. AID PROJECT			

DATE	
BY	
ORIGINAL SURVEY	
FLUORIDED	
NOTE BOOK	
AREAS CHECKED	

DATE	
BY	
ORIGINAL SURVEY	
FLUORIDED	
NOTE BOOK	
AREAS CHECKED	

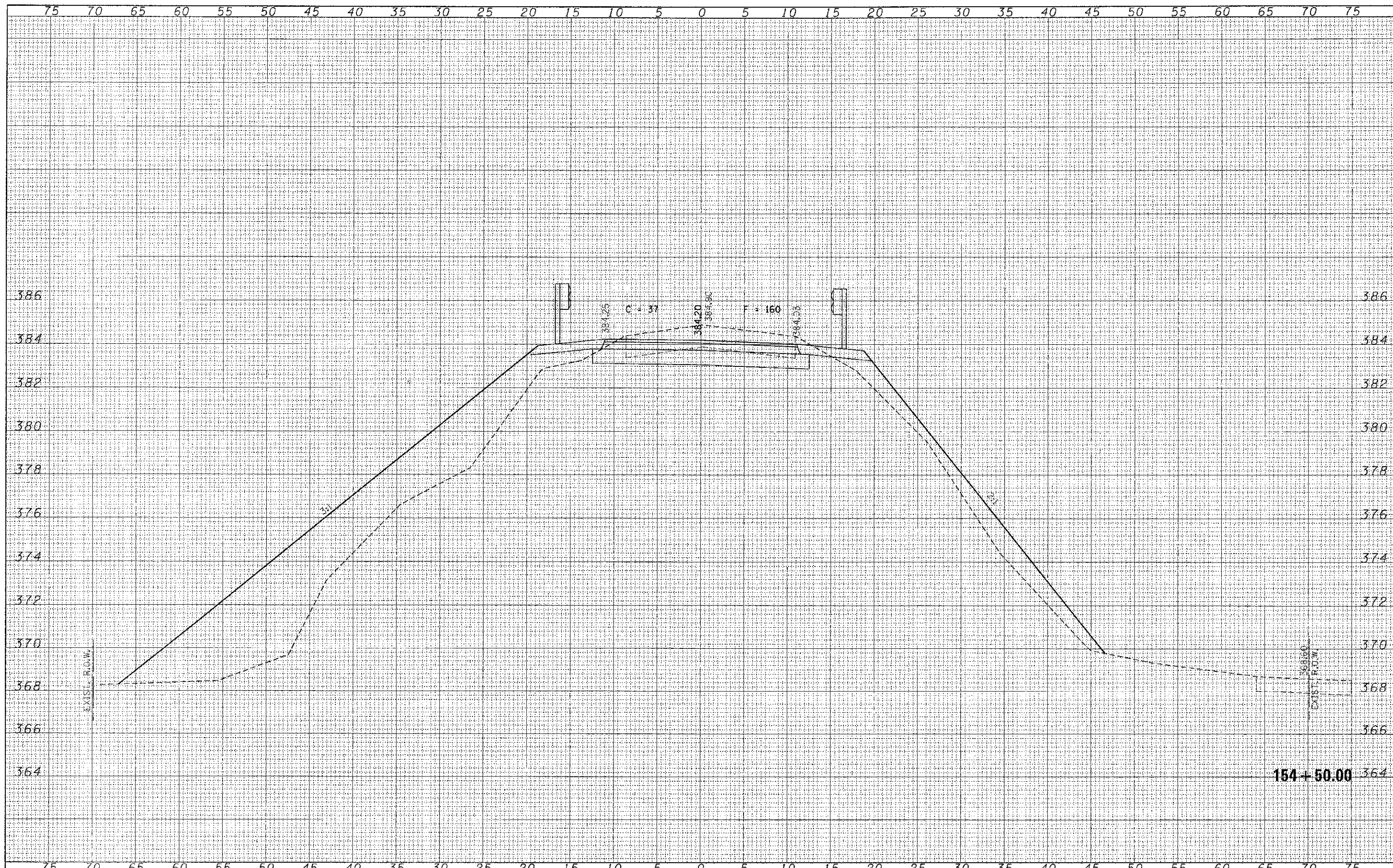

FILE NAME = 220127-ahb-ssw.dgn	USER NAME =	DESIGNED - J.W.F.	REVISED -	STATE OF ILLINOIS JACKSON COUNTY HIGHWAY DEPARTMENT	STATION CROSS SECTIONS DILLINGER ROAD			C.H.	SECTION	COUNTY	TOTAL SHEETS
HAMPTON, LENZINI AND RENWICK, INC.		DRAWN - L.G.C.	REVISED -		II	06-00145-00-BR	JACKSON	54	24		
380 STEVENSON BLVD. SUITE 203 SPRINGFIELD, ILLINOIS 62761		CHECKED - S.W.M.	REVISED -		CARBONDALE ROAD DISTRICT			CONTRACT NO. 99509			
ILLINOIS PROFESSIONAL DESIGNERS 13, PE, 38 CORP. 144 009933		DATE - 04/04/13	REVISED -		ILLINOIS FED. AID PROJECT						

SCALE: V5H12 SHEET NO. OF SHEETS STA. 154+50.00 TO STA. 154+50.00

FILE	SURVEYED	DATE
SHEET	PLotted	BY
NOTE BOOK	REPLATE	
NO.	AREA CHECKED	

FILE	SURVEYED	DATE
SHEET	PLotted	BY
NOTE BOOK	REPLATE	
NO.	AREA CHECKED	

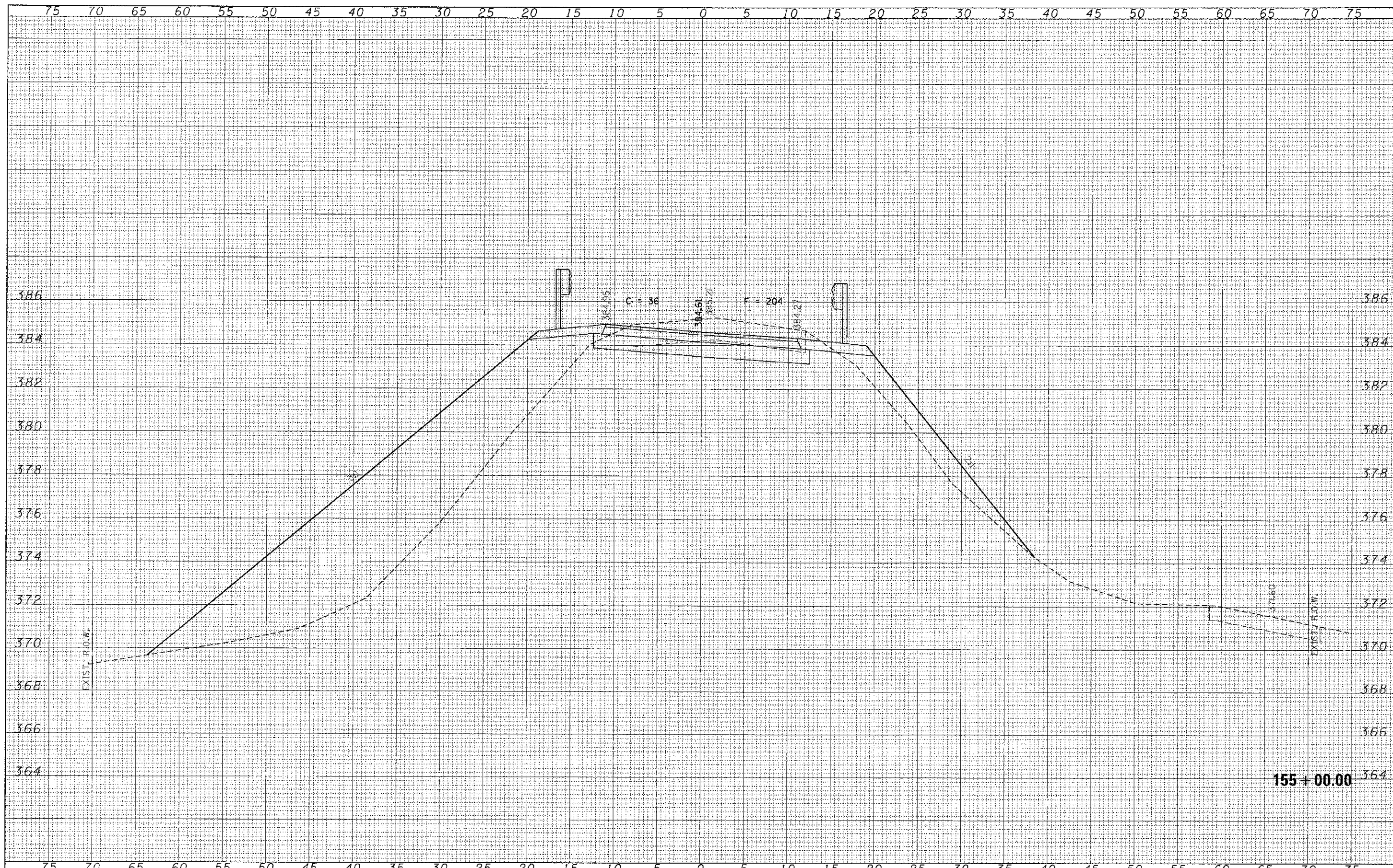

FILE NAME = 120127-vr-t-svs.dgn	USER NAME =	DESIGNED - J.W.F.	REVISED -	STATE OF ILLINOIS JACKSON COUNTY HIGHWAY DEPARTMENT	STATION CROSS SECTIONS DILLINGER ROAD			C.H.	SECTION	COUNTY	TOTAL SHEET NO.
HAMPTON, LENZINI AND RENWICK, INC.		DRAWN - L.G.C.	REVISED -		11	06-00146-00-BR	JACKSON	54	25		
383 STEVENSON DRIVE SUITE 201 SPRINGFIELD, ILLINOIS 62761		CHECKED - S.W.M.	REVISED -		CARBONDALE ROAD DISTRICT			CONTRACT NO. 99509			
ILLINOIS PROFESSIONAL ENGINEERING FIRM 1817 E. 98th ST. #1420		DATE - 04/04/13	REVISED		SCALE: V5H2			SHEET NO. OF SHEETS STA. 155+00.00 TO STA. 155+00.00			

155+00.00

ILLINOIS FED. AID PROJECT

DATE	
BY	
REVISIONS	
NO.	
DATE	
BY	
REVISIONS	
NO.	
DATE	
BY	
REVISIONS	
NO.	
DATE	
BY	
REVISIONS	
NO.	
DATE	
BY	
REVISIONS	
NO.	
DATE	
BY	
REVISIONS	
NO.	

DATE	
BY	
REVISIONS	
NO.	
DATE	
BY	
REVISIONS	
NO.	
DATE	
BY	
REVISIONS	
NO.	
DATE	
BY	
REVISIONS	
NO.	
DATE	
BY	
REVISIONS	
NO.	

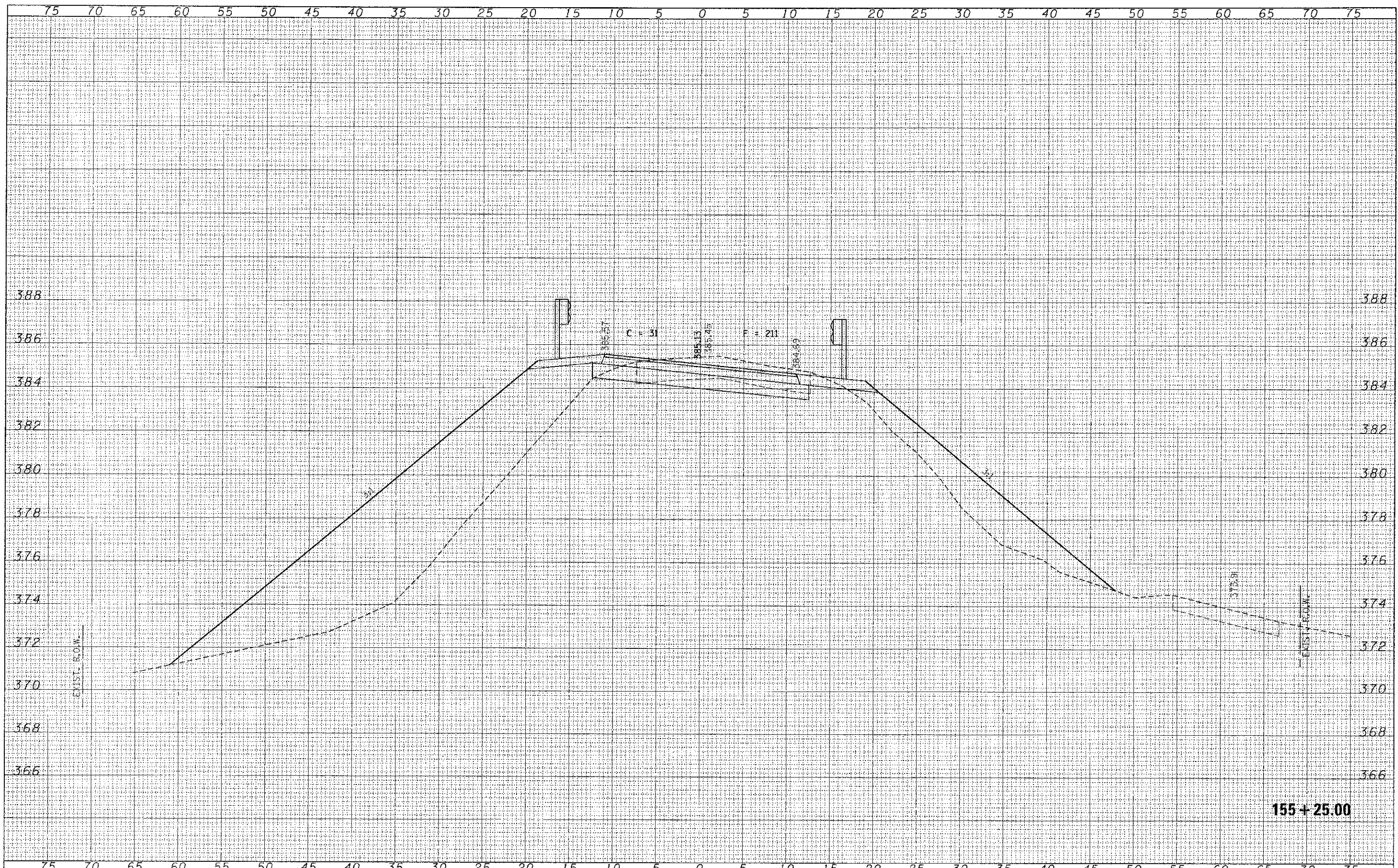

155 + 25.00

FILE NAME = 12E127-ehh-ss.dgn	USER NAME =	DESIGNED - J.W.F.	REVISED -	STATE OF ILLINOIS JACKSON COUNTY HIGHWAY DEPARTMENT	STATION CROSS SECTIONS DILLINGER ROAD		C.H.	SECTION	COUNTY	TOTAL SHEETS	SHEET NO.
HAMPTON LENZINI AND REAVERICK INC.		DRAWN - J.G.C.	REVISED -		11	06-00145-00-BR	JACKSON	54	26		
3045 OTOLEBORO CENTER SUITE 200		CHECKED - S.W.M.	REVISED -		CARBONDALE ROAD DISTRICT				CONTRACT NO. 99509		
SPRINGFIELD, ILLINOIS 62701		DATE - 04/04/13	REVISED -		ILLINOIS FED. AID PROJECT						
ILLINOIS PROFESSIONAL DESIGN FIRM				SCALE: V5:H2		SHEET NO.	OF	SHEETS	STA. 155+25.00	TO STA. 155+25.00	

DATE	
BY	
REVISIONS	
NO.	
DATE	
BY	
REVISIONS	
NO.	
DATE	
BY	
REVISIONS	
NO.	

DATE	
BY	
REVISIONS	
NO.	
DATE	
BY	
REVISIONS	
NO.	
DATE	
BY	
REVISIONS	
NO.	

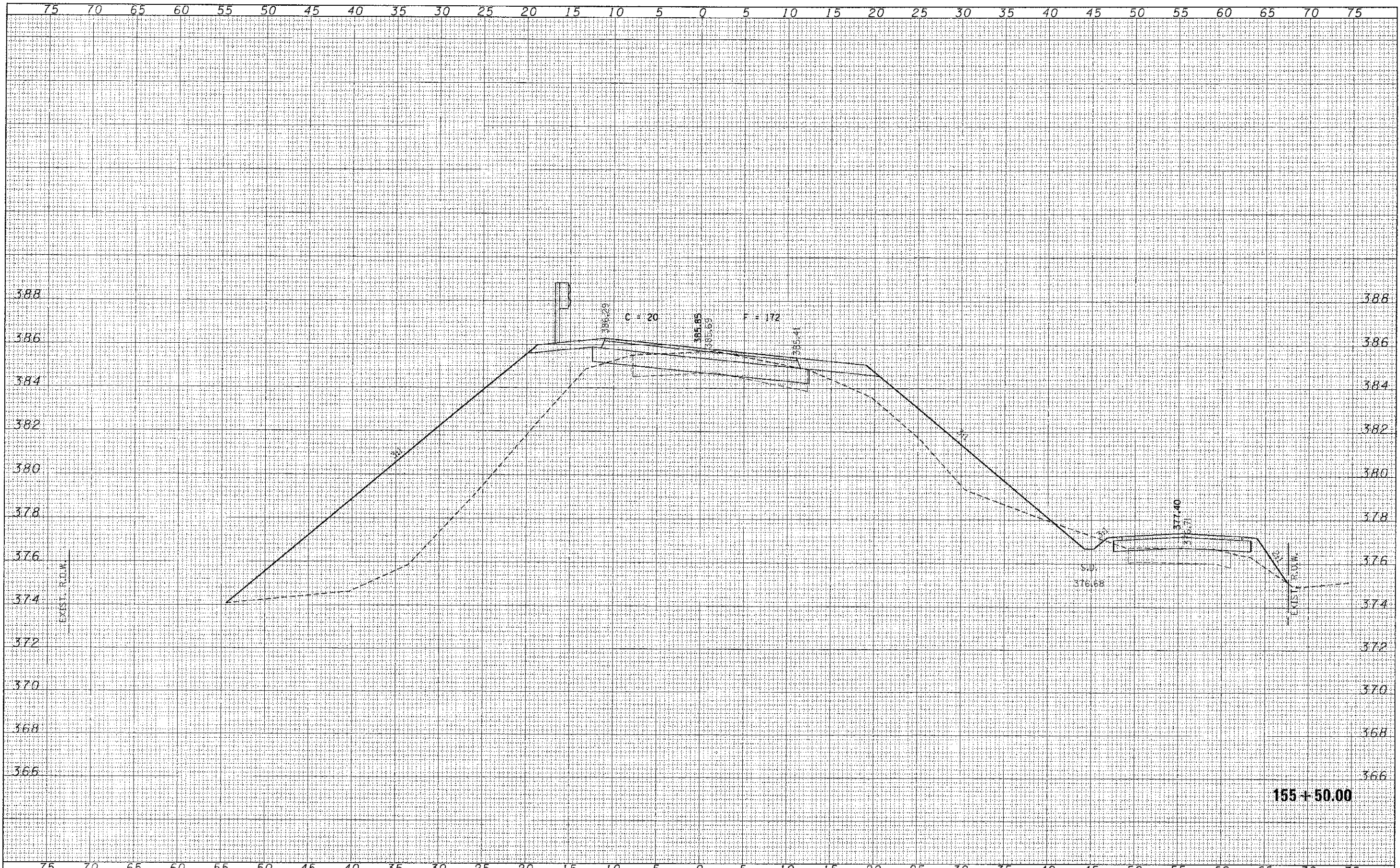

155+50.00

FILE NAME * 28127-hnt+stc.dgn	USER NAME *	DESIGNED - J.W.F.	REVISED -	STATE OF ILLINOIS JACKSON COUNTY HIGHWAY DEPARTMENT	STATION CROSS SECTIONS DILLINGER ROAD		C.H.	SECTION	COUNTY	TOTAL SHEET NO.
HAMPTON, LENZINI AND RENWICK, INC.		DRAWN - L.G.C.	REVISED -		11	06-00145-00-BR	JACKSON	54	27	
1000 S. EVERETT ST. SUITE 201 SPRINGFIELD, IL 62761-1013		CHECKED - S.W.M.	REVISED -		CARBONDALE ROAD DISTRICT				CONTRACT NO. 99509	
ILLINOIS PROFESSIONAL ENGINEERING FIRM 137 W. 11TH ST. ST. LOUIS, MO 63103		DATE - 04/04/13	REVISED		SCALE: V5:H2	SHEET NO. OF SHEETS	STA. 155+50.00 TO STA. 155+50.00	ILLINOIS FED. AID PROJECT		

DATE	
BY	
FINAL SURVEY	
FLIPPED	
TEMPLATE	
NOTE BOOK	
AREAS CHECKED	
NO.	

DATE	
BY	
ORIGINAL SURVEY	
FLIPPED	
TEMPLATE	
NOTE BOOK	
AREAS CHECKED	
NO.	

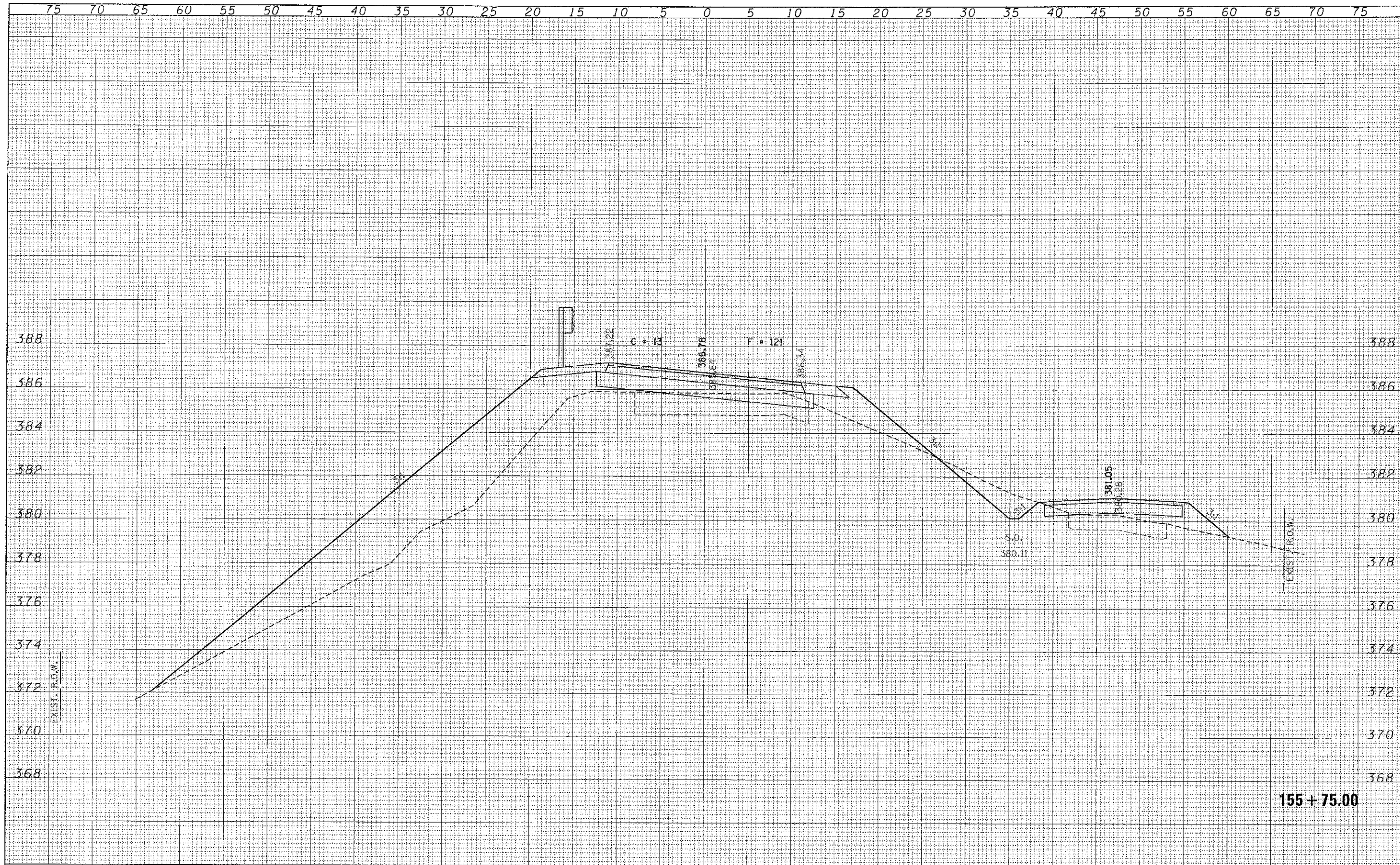

155+75.00

FILE NAME = 122127-sh-t-xxx.dgn	USER NAME =	DESIGNED - J.W.F.	REVISED -	<p align="center">STATE OF ILLINOIS JACKSON COUNTY HIGHWAY DEPARTMENT</p> <p align="center">STATION CROSS SECTIONS DILLINGER ROAD</p>	C.H.	SECTION	COUNTY	TOTAL SHEET SHEETS
HAMPTON, LENZINI AND RENWICK, INC. 348 STEUBENSON DRIVE SUITE 207 SPRINGFIELD, ILLINOIS 62761	FLIP SCALE =	DRAWN - L.G.C.	REVISED -		11	06-00145-00-BR	JACKSON	54
ILLINOIS PROFESSIONAL ENGINEER REGISTRATION BOARD 144 NORTH 2ND STREET, SUITE 1000 SPRINGFIELD, ILLINOIS 62761	FLIP DATE = 4/9/2013	CHECKED - S.W.M.	REVISED -		CARBONDALE ROAD DISTRICT		CONTRACT NO. 99509	
		DATE - 04/04/13	REVISED -		ILLINOIS FED. AID PROJECT			

SCALE: V5:H2 SHEET NO. OF SHEETS STA. 155+75.00 TO STA. 155+75.00

FINAL SURVEY	SURVEYED	DATE
NOTE BOOK	PLOTTED	BY
NO.	TEMPERATURE	
	AREAS CHECKED	

ORIGINAL SURVEY	DATE
NOTE BOOK	BY
NO.	

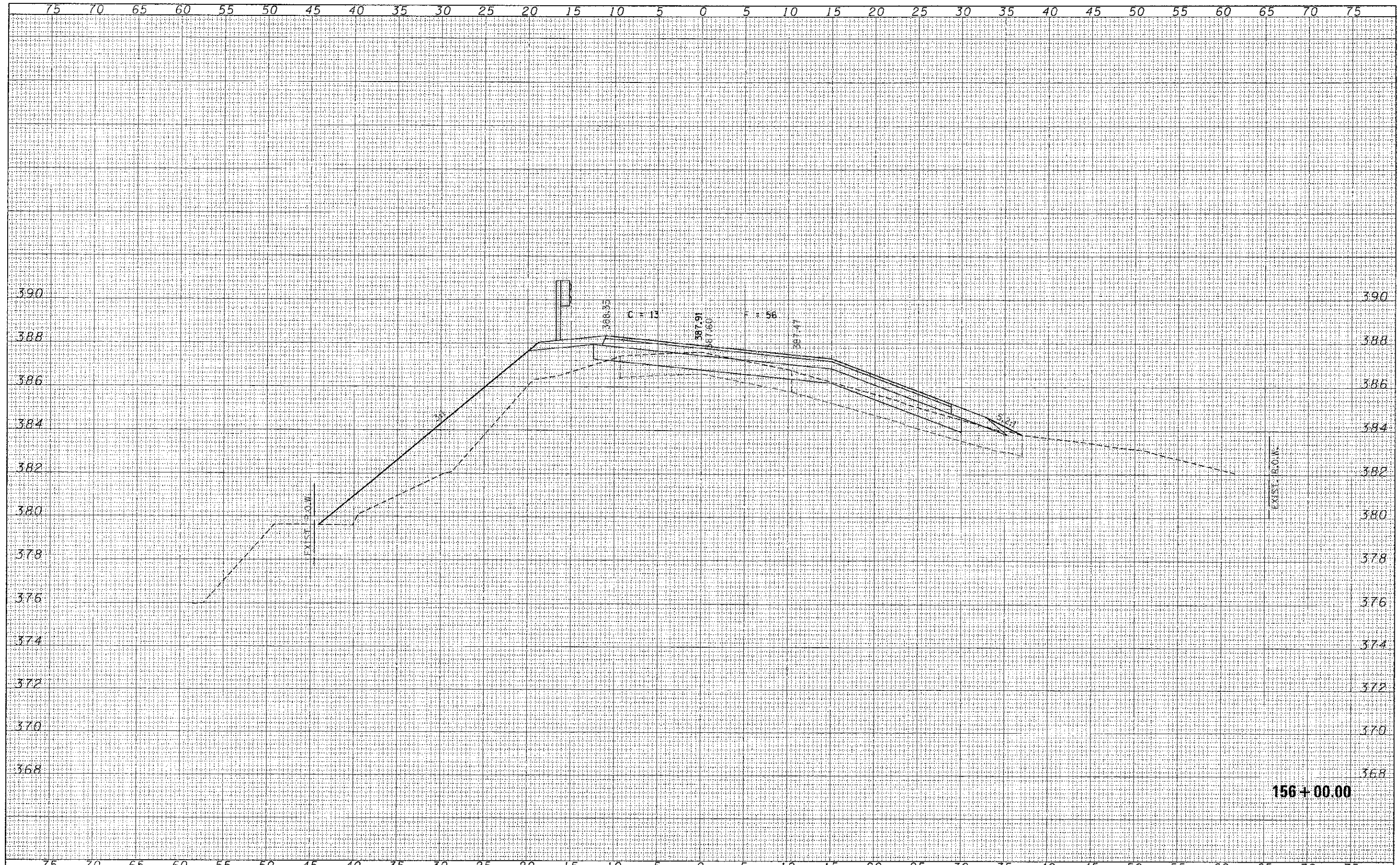

FILE NAME = 128-27-sht.evdgn	USER NAME =	DESIGNED - J.W.F.	REVISED -	STATE OF ILLINOIS JACKSON COUNTY HIGHWAY DEPARTMENT	STATION CROSS SECTIONS DILLINGER ROAD				
HAMPTON, LENZINI AND RENWICK, INC. 200 STEVENSON DRIVE SUITE 201 SPRINGFIELD, ILLINOIS 62701 ILLINOIS PROFESSIONAL REG. NO. 158-007254	DESIGNED - J.W.F.	REVISIONS			C.H.	SECTION	COUNTY	TOTAL SHEETS	SHEET NO.
PLLOT SCALE =	DRAWN - L.G.C.	REVISIONS			11	06-00145-00-BR	JACKSON	54	29
PLLOT DATE = 4/9/2013	CHECKED - S.W.M.	REVISIONS			CARBONDALE ROAD DISTRICT		CONTRACT NO. 99509		
	DATE - 04/04/13	REVISIONS		ILLINOIS FED. AID PROJECT					

SCALE: V5H2 SHEET NO. OF SHEETS STA. 156+00.00 TO STA. 156+00.00

DATE	
BY	
ORIGINAL SURVEY	
FLIPPED	
NOTED BOOK	
AREAS CHECKED	
NO.	

DATE	
BY	
ORIGINAL SURVEY	
FLIPPED	
NOTED BOOK	
AREAS CHECKED	
NO.	

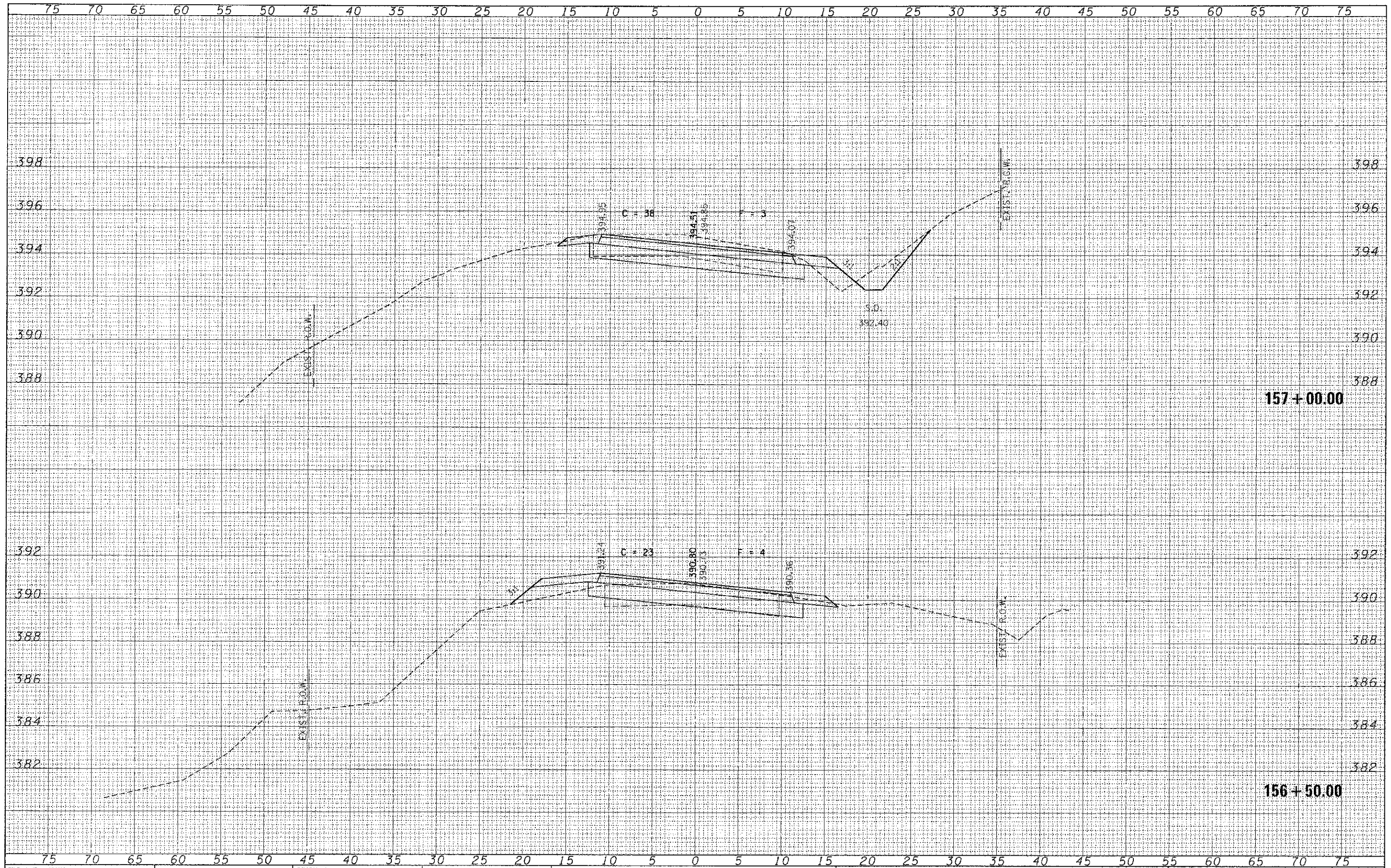

FILE NAME = 120127-el.c:\sxa\sign
 HAMPTON, LENZINI AND RENWICK, INC.
 1000 STATE STREET, SUITE 201
 SPRINGFIELD, ILLINOIS 62761
 LL-1000 PROFESSIONAL SERVICE FIRM
 LICENSE NO. 041000000

USER NAME
 PLOT SCALE =
 PLOT DATE = 4/9/2013

DESIGNED - J.W.F.
 DRAWN - L.G.C.
 CHECKED - S.W.M.
 DATE - 04/04/13

REVISED -
 REVISED -
 REVISED -
 REVISED -

STATE OF ILLINOIS
 JACKSON COUNTY HIGHWAY DEPARTMENT

STATION CROSS SECTIONS
 DILLINGER ROAD
 SCALE: V5:H2
 SHEET NO. OF SHEETS STA. 156+50.00 TO STA. 157+00.00

C-I.	SECTION	COUNTY	TOTAL SHEETS	SHEET NO.
11	06-00145-00-BR	JACKSON	54	30
CARBONDALE ROAD DISTRICT			CONTRACT NO. 99509	
ILLINOIS FED. AID PROJECT				

FINAL	DATE
SURVEY	BY
NOTED	BY
PLANNED	BY
REVISIONS	BY
DATE	BY

ORIGINAL	DATE
SURVEY	BY
NOTED	BY
PLANNED	BY
REVISIONS	BY
DATE	BY

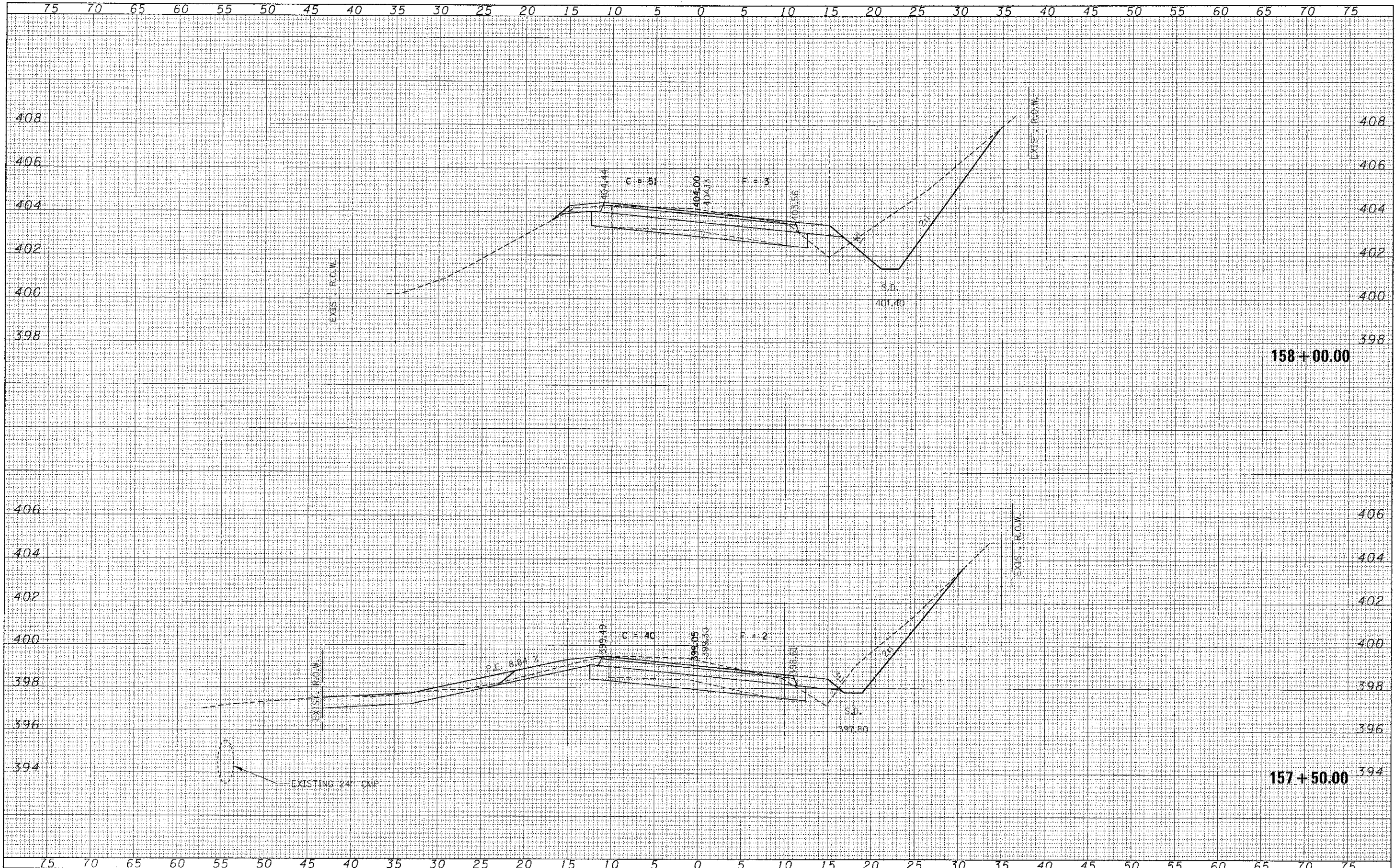

FILE NAME * 120127-shr-exis.dgn	USER NAME *	DESIGNED - J.W.F.	REVISIONS -	STATE OF ILLINOIS JACKSON COUNTY HIGHWAY DEPARTMENT	STATION CROSS SECTIONS					
HAMPTON, LENZINI AND RENWICK, INC.		DRAWN - L.G.C.	REVISIONS -		DILLINGER ROAD					
300 S. STATE ST. SUITE 201 SPRINGFIELD, IL 62761		CHECKED - S.W.M.	REVISIONS -		C.H.	SECTION	COUNTY	TOTAL SHEETS	SHEET NO.	
ILLINOIS PROFESSIONAL ENGINEERING FIRM 3/7/97 IRE CCA* 04-00032		DATE - 04/04/13	REVISIONS -		11	06-00145-00-BR	JACKSON	54	31	
					SCALE: V5H2		SHEET NO. OF SHEETS		S1A, 157+50.00 TO STA. 158+00.00	
					CARBONDALE ROAD DISTRICT CONTRACT NO. 99509				ILLINOIS FED. AID PROJECT	

DATE	BY
ORIGINAL SURVEY	SURVEYED
NOTE BOOK	PLOTTED
AREAS CHECKED	REVISIONS

DATE	BY
ORIGINAL SURVEY	SURVEYED
NOTE BOOK	PLOTTED
AREAS CHECKED	REVISIONS

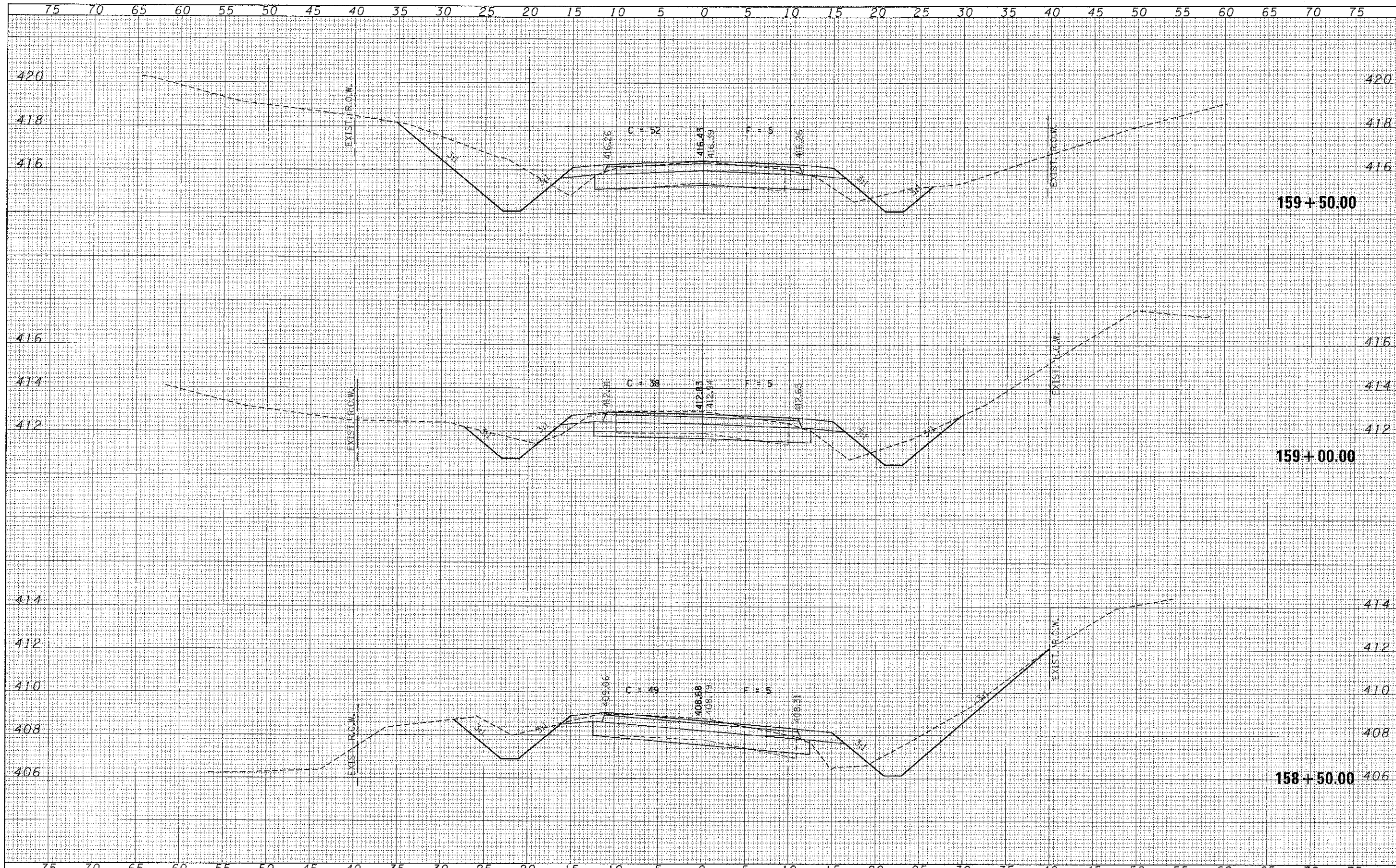

FILE NAME = 120127-shr-annuldr	USER NAME =	DESIGNED - J.W.F.	REVISED -	STATE OF ILLINOIS JACKSON COUNTY HIGHWAY DEPARTMENT	STATION CROSS SECTIONS DILLINGER ROAD				
HAMPTON, LENZINI AND RENWICK, INC. 300 STEPHENSON DRIVE SUITE 201 SPRINGFIELD, ILLINOIS 62761	PLLOT SCALE =	DRAWN - L.G.C.	REVISED -		C.H.	SECTION	COUNTY	TOTAL SHEETS	SHEET NO.
ILLINOIS PROFESSIONAL DESIGN FIRM L.S. #21362-0100 104-300159	PLLOT DATE = 4/9/2013	CHECKED - S.W.M.	REVISED -		11	06-00145-00-BR	JACKSON	54	32
		DATE - 04/04/13	REVISED -		CARBONDALE ROAD DISTRICT		CONTRACT NO. 99509		ILLINOIS FED. AID PROJECT

SCALE: V5:H2 SHEET NO. OF SHEETS STA. 158+50.00 TO STA. 159+50.00

DATE	
BY	
FM	
SRVY	
NOTE	
BOOK	
NO.	
DATE	
BY	
FM	
SRVY	
NOTE	
BOOK	
NO.	

DATE	
BY	
FM	
SRVY	
NOTE	
BOOK	
NO.	
DATE	
BY	
FM	
SRVY	
NOTE	
BOOK	
NO.	

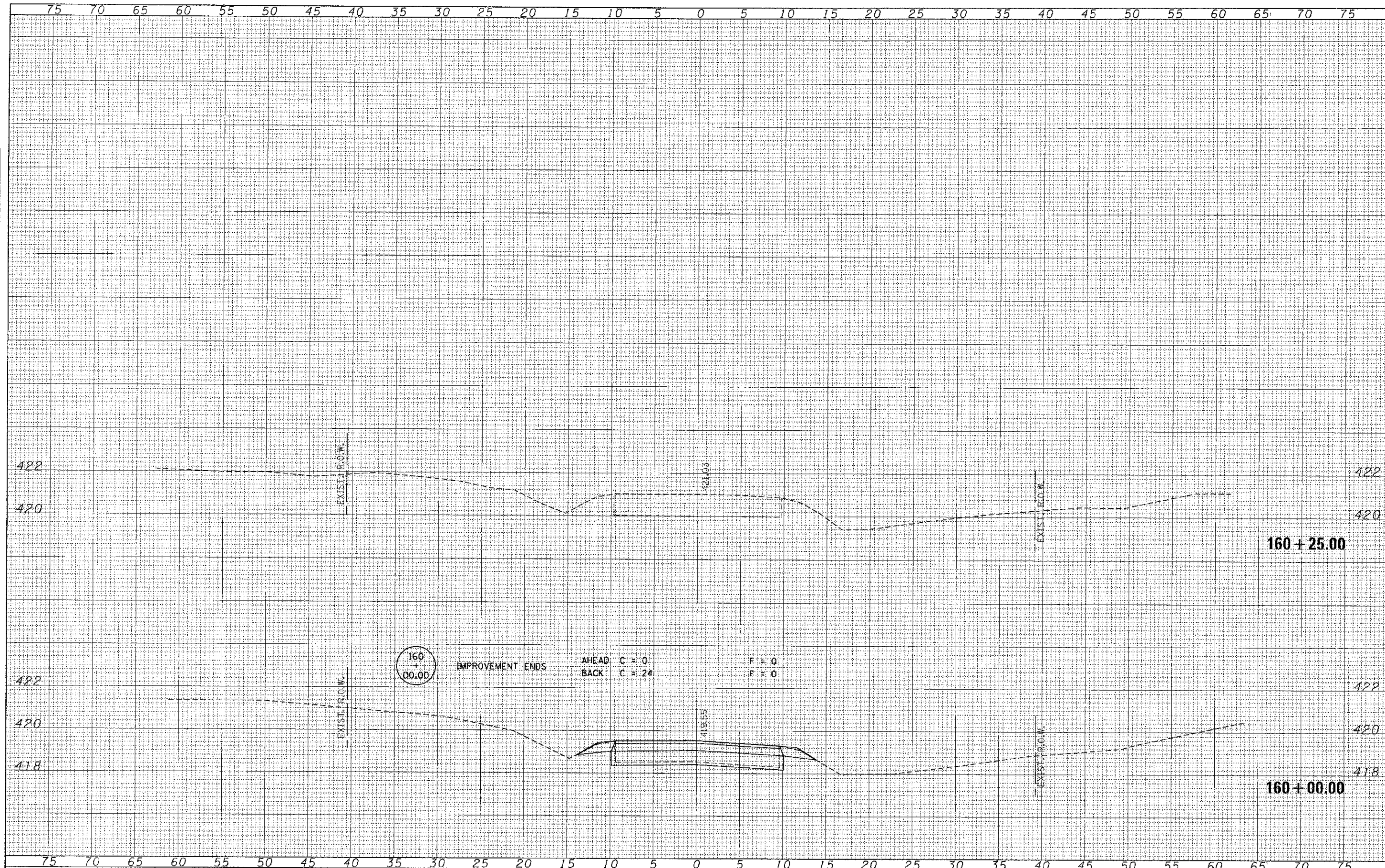

FILE NAME = 123121-4ht-sss.dgn	USER NAME =	DESIGNED - J.W.F.	REVISED -	STATE OF ILLINOIS JACKSON COUNTY HIGHWAY DEPARTMENT	STATION CROSS SECTIONS DILLINGER ROAD				C.H.	SECTION	COUNTY	TOTAL SHEETS	SHEET NO.
HAMPTON, LENZINI AND RENWICK, INC. 508 S. CEDAR ST. DEPT. 201 SPRINGFIELD, ILL. 62761	FLDT SCALE =	DRAWN - L.G.C.	REVISED -						11	05-00145-00-BR	JACKSON	54	33
AL ILLINOIS PROFESSIONAL DESIGN FIRM CERT. NO. 154,000-058	PLDT DATE = 4/9/2013	CHECKED - S.W.M.	REVISED -		CARBONDALE ROAD DISTRICT CONTRACT NO. 99509								
		DATE - 04/04/13	REVISED -		ILLINOIS FED. AID PROJECT								

BENCHMARK: Mag spike in power pole. 32' RT, Sta. 148+04. Elev 383.71

EXISTING STRUCTURE: Structure No. 039-3097, Built in 1968 under Section 104B-1R. The existing superstructure consists of 5 spans of 9 PPC Deck Beams with a back-to-back of abutment length of 286'-6 3/4", an out to out width of 28'-4", a 3"± HMA wearing surface, and concrete curb and hand rail. The existing substructure consists of reinforced concrete pile supported stub abutments and reinforced concrete single column piers on spread footings and piles. The existing superstructure is to be removed and replaced. Road closed to traffic during construction.

No Salvage

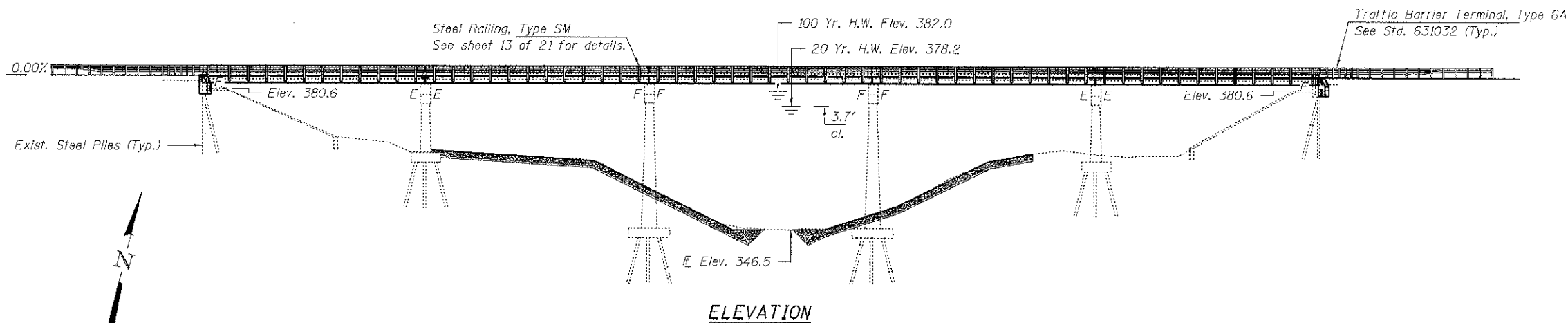

INDEX OF STRUCTURE SHEETS

1. General Plan & Elevation
2. General Data
- 3-4. 21"x36" PPC Deck Beam - Spans 1 & 5
5. 21"x36" PPC Deck Beam Details - Spans 1 & 5
- 6-7. 21"x36" PPC Deck Beam - Spans 2 & 4
8. 21"x36" PPC Deck Beam Details - Spans 2 & 4
9. 21"x36" PPC Deck Beam - Span 3
10. 21"x36" PPC Deck Beam Details - Span 3
- 11-12. Superstructure Details
13. Steel Railing, Type SM with Hot Mix Asphalt Wearing Surface
14. Abutments
15. Piers
- 16-21. Existing Structure Plans

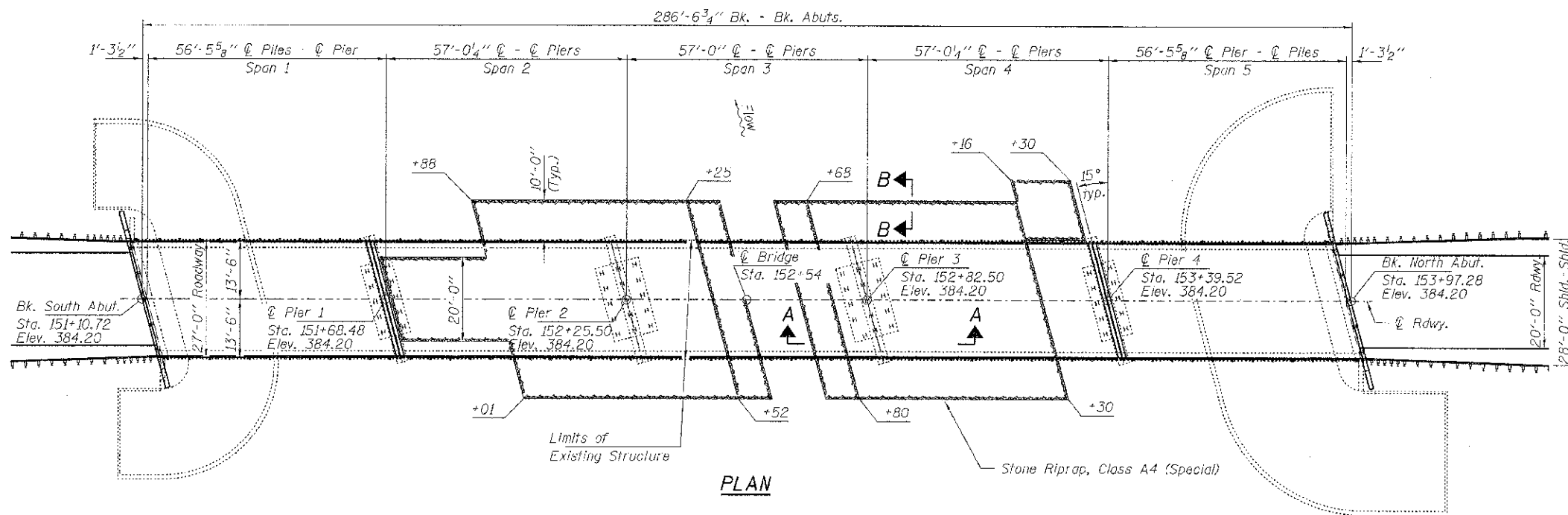

DESIGN STRESSES

FIELD UNITS (NEW CONST.)

$f'_c = 3,500$ psi
 $f_y = 60,000$ psi (Reinf.)

PRECAST PRESTRESSED UNITS

$f'_c = 6,000$ psi
 $f'_ci = 5,000$ psi
 $f_{pu} = 270,000$ psi (1/2" low lax. strands)
 $f_{pbt} = 201,960$ psi (1/2" low lax. strands)
 $f_y = 60,000$ psi (Reinf.)

FIELD UNITS (EXIST. CONST.)

$f'_c = 3,500$ psi
 $f_y = 40,000$ psi (Reinforcement)

DESIGN SPECIFICATIONS

NEW CONSTRUCTION

2012 AASHTO LRFD Bridge Design Specifications

LOADING HL-93-SUPERSTRUCTURE

25#/Sq. Ft. included in dead load for HMA wearing surface.
 Allow 25#/Sq. Ft. for future wearing surface.

LOADING HS-15-SUBSTRUCTURE

(Existing Construction)

I certify that to the best of my knowledge, information and belief, this bridge design is structurally adequate for the design loading shown on the plans. The design is an economical one for the style of structure and complies with requirements of the current "AASHTO LRFD Specifications."

Steven W. Megginson 03/12/2013
 ILLINOIS STRUCTURAL ENGINEER NO. 081-6064

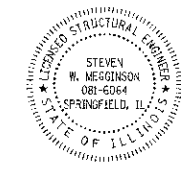

Expires 11-30-2014

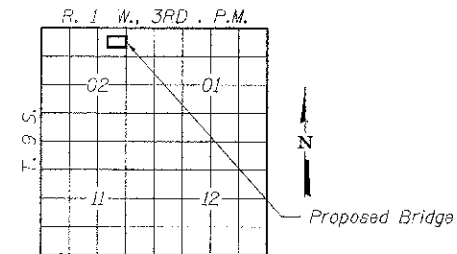

LOCATION SKETCH

FILE NAME = 120127-shv-bridge.dgn	USER NAME =	DESIGNED - D.W.T.	REVISED -	STATE OF ILLINOIS DEPARTMENT OF TRANSPORTATION	GENERAL PLAN & ELEVATION STRUCTURE NO. 039-3097	C.K.	SECTION	COUNTY	TOTAL SHEETS	SHEET NO.
HAMPTON, LENZINI AND RENWICK, INC. 3045 STEVENSON DRIVE, SUITE 201 SPRINGFIELD, ILLINOIS 62703	PLOT SCALE =	CHECKED - S.W.M.	REVISED -			II	06-00145-00-BR	JACKSON	54	34
ILLINOIS PROFESSIONAL DESIGN #1193 16 / P. 26 CORP. 12-2009	PLOT DATE = 4/9/2013	DRAWN - D.A.B.	REVISED -			DILLINGER ROAD		CONTRACT NO. 99509		
		CHECKED - S.W.M.	REVISED -			SHEET NO. 1 OF 21 SHEETS		ILLINOIS FED. AID PROJECT		

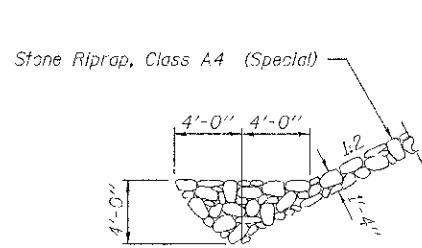

SECTION A-A

Note: See Special Provisions for Stone Riprap, Class A4.

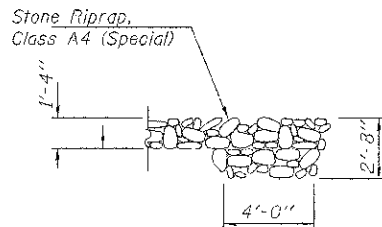

SECTION B-B

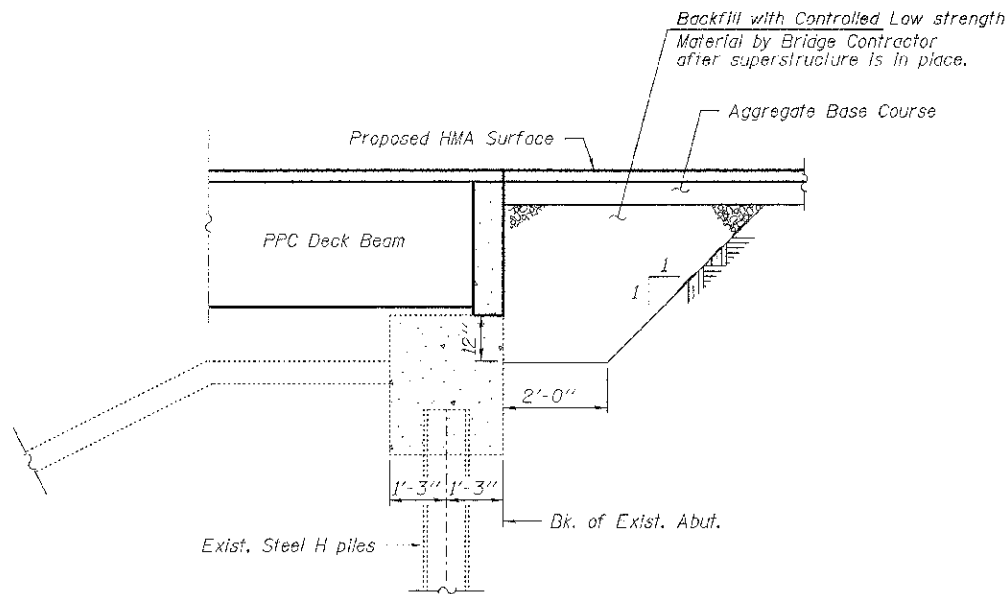

SECTION THRU ABUTMENT

(Horiz. dim. @ Rt. L's)

CRAB ORCHARD CREEK
REBUILT 201 BY
JACKSON COUNTY
SEC. 06-00145-00-BR
STR. NO. 039-3097
LOADING HI -93

NAME PLATE

See Std. 515001

Existing Name Plate shall be cleaned and relocated next to new Name Plate. Cost included with Name Plates.

GENERAL NOTES

Plan dimensions and details relative to existing plans are subject to nominal construction variations. The Contractor shall field verify existing dimensions and details affecting new construction and make necessary approved adjustments prior to construction or ordering of materials. Such variations shall not be cause for additional compensation for a change in scope of the work, however, the Contractor will be paid for the quantity actually furnished at the unit price bid for the work.

Layout of the slope protection system may be varied to suit ground conditions in the field as directed by the Engineer.

Reinforcement bars shall conform to the requirements of ASTM A 706 Gr 60. See Special Provisions.

Reinforcement bars designated (E) shall be epoxy coated.

Existing dowel rods shall be burned off flush with the existing substructure. Grind existing dowel rods smooth and seal with epoxy. Cost included with Removal of Existing Superstructures.

Removal of the existing bridge parapet shall be included in the cost of Removal of Existing Superstructures.

Removal of any existing pavement and base material located above the existing abutments shall be included with the cost of Removal of Existing Superstructures.

All proposed construction activities shall be in accordance with Nationwide Permit number 14 of the Department of the Army authorized under Section 404 of the Clean Water Act. The IEPA has issued Section 401 Water Quality Certification for this activity. See Special Provisions for conditions.

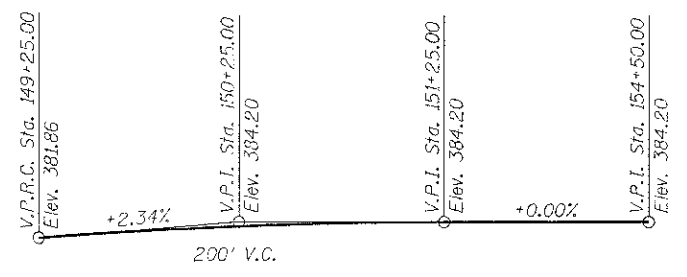

PROFILE GRADE

DESIGN SCOUR ELEVATION TABLE

Design Scour Elevation (ft.)	S. Abut.	PIER 1	PIER 2	PIER 3	PIER 4	N. Abut.
	379.0	332.0	333.0	341.0	345.0	379.0

WATERWAY INFORMATION

Flood	Freq. Yr.	Q C.F.S.	Opening Sq. Ft.		Head - Ft.		Headwater El.	
			Exist.	Prop.	Natural h.w.e.	Exist. Prop.	Exist.	Prop.
Design	10	9600	3390	3390	376.4			
Base/Overtopping	20	10300	3810	3810	378.2			
	100	14400	4720	4720	382.0			

Existing Low Grade Elev. 380.9 @ Sta. 148+50
Proposed Low Grade Elev. 380.9 @ Sta. 148+50
10 Year Velocity through Existing Bridge = 2.5 fps
10 Year Velocity through Proposed Bridge = 2.5 fps

TOTAL BILL OF MATERIAL

ITEM	UNIT	SUPER	SUB	TOTAL
Stone Riprap, Class A4 (Special)	Ton			610
Hot-Mix Asphalt Surface Course, Mix C, N50	Ton	95		95
Removal of Existing Superstructures	Each	1		1
Concrete Removal	Cu. Yd.		6.0	6.0
Structure Excavation	Cu. Yd.			54
Concrete Structures	Cu. Yd.		7.4	7.4
Concrete Superstructures	Cu. Yd.	2.6		2.6
Precast Prestressed Concrete Deck Beams (21" Depth)	Sq. Ft.	7,685		7,685
Reinforcement Bars, Epoxy Coated	Pound	580	960	1,540
Steel Railing, Type SM	Foot	572		572
Name Plates	Each		1	1
Preformed Joint Strip Seal	Foot	56		56
P.C. Mortar Fairing Course	Foot	570		570
Concrete Sealer	Sq. Ft.		104	104
Waterproofing Membrane System	Sq. Yd.	849		849
Controlled Low Strength Material	Cu. Yd.			14
Asbestos Bearing Pad Removal	Each	36		36
Structural Repair of Concrete (Depth equal to or less than 5 inches)	Sq. Ft.		60	60

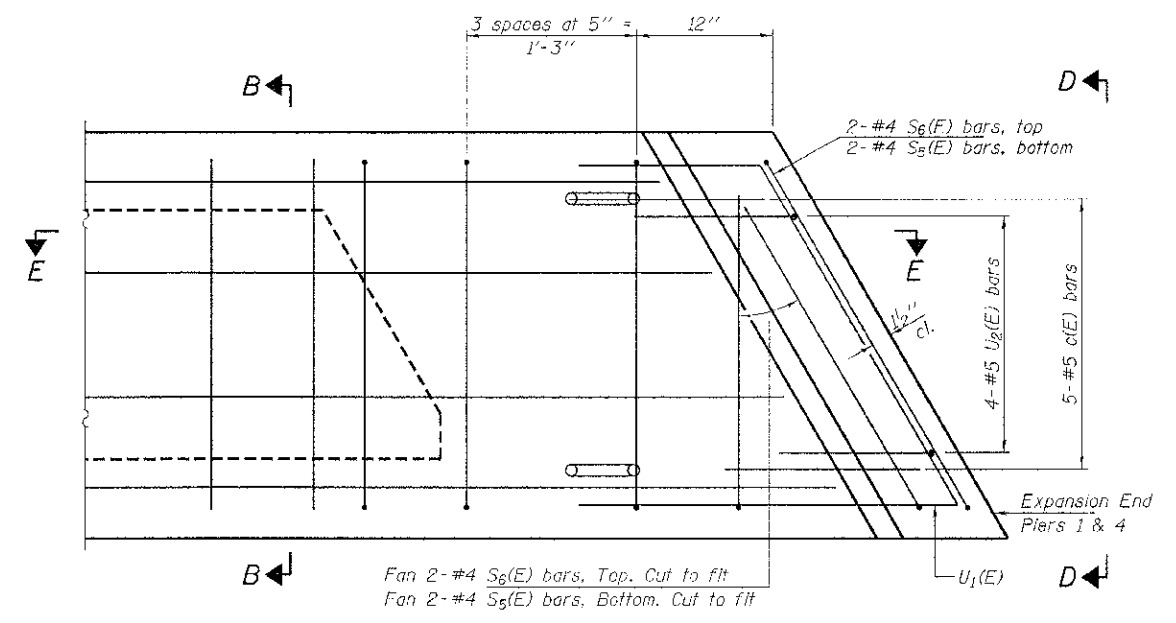
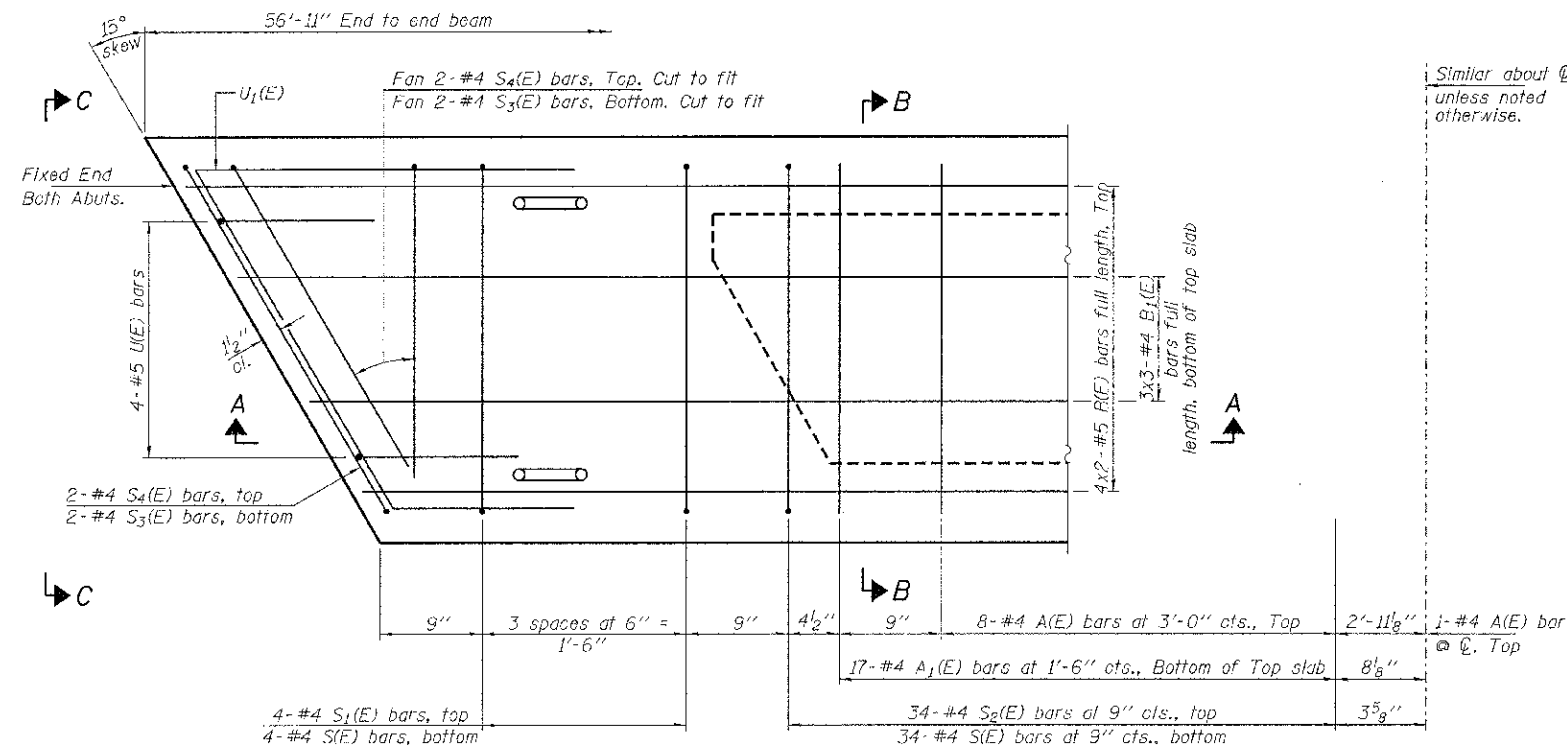

PLAN VIEW

BAR LIST
ONE BEAM ONLY
(For information only)

Bar	No.	Size	Length	Shape
A(F)	17	#4	2'-7"	—
A1(E)	34	#4	2'-10"	—
B(E)	8	#5	29'-7"	—
B1(E)	9	#4	20'-3"	—
C(E)	5	#5	3'-8"	—
S(E)	76	#4	6'-5"	—
S1(E)	8	#4	4'-11"	—
S2(F)	68	#4	5'-2"	—
S3(E)	4	#4	4'-2"	—
S4(E)	4	#4	3'-5"	—
S5(E)	4	#4	3'-8"	—
S6(E)	4	#4	2'-11"	—
U1(E)	4	#5	4'-0"	—
U2(E)	3	#5	5'-9"	—
U3(E)	4	#5	5'-2"	—

Notes:
Spacing of S1(E) and S2(E) bars may be adjusted up to 4" in the immediate area of the transverse tie diaphragms to miss the block outs for the transverse ties.
Bars indicated thus 4x2-#5 etc. indicates 4 lines of bars with 2 lengths per line.
See sheet 4 of 21 for SECTION A-A, SECTION B-B, VIEW C-C, VIEW D-D & SECTION E-E.

MINIMUM BAR LAP
#4 bar = 2'-0"
#5 bar = 2'-6"

Note: See sheets 4 & 5 of 21 for additional details and Bill of Material.

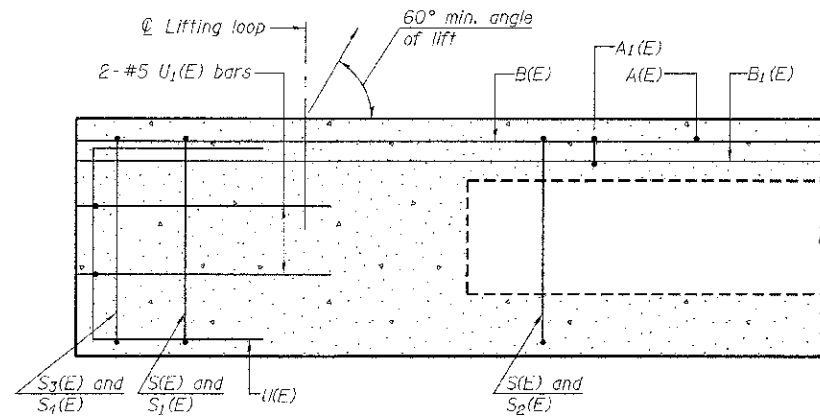

SECTION A-A

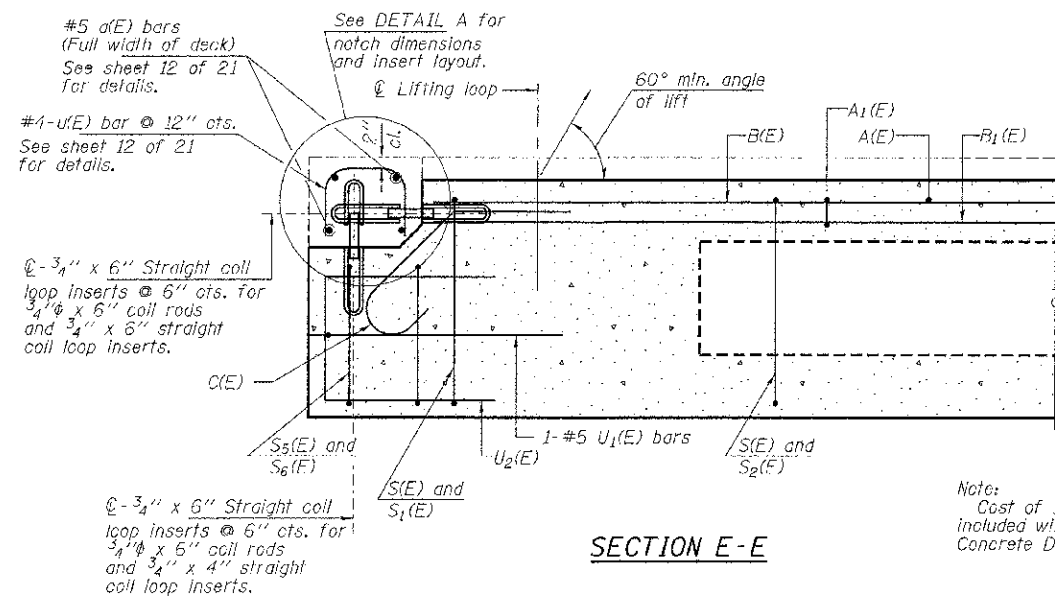

SECTION E-E

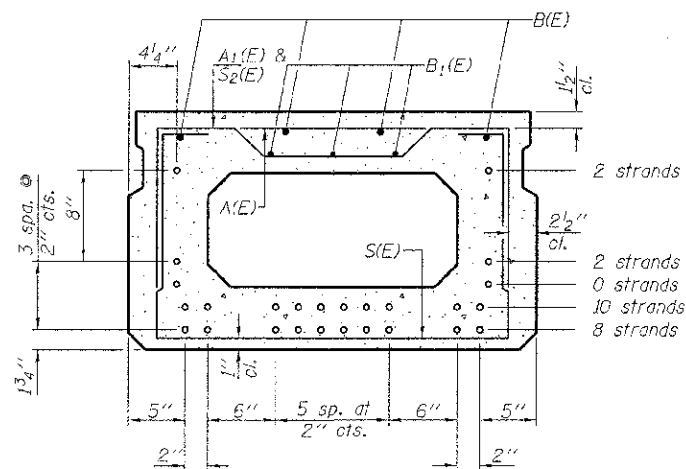

SECTION B-B

(Showing reinforcement and permissible strand locations)

Note: Place the number of strands specified in each row symmetrically about the centerline of beam in the permissible strand locations shown.

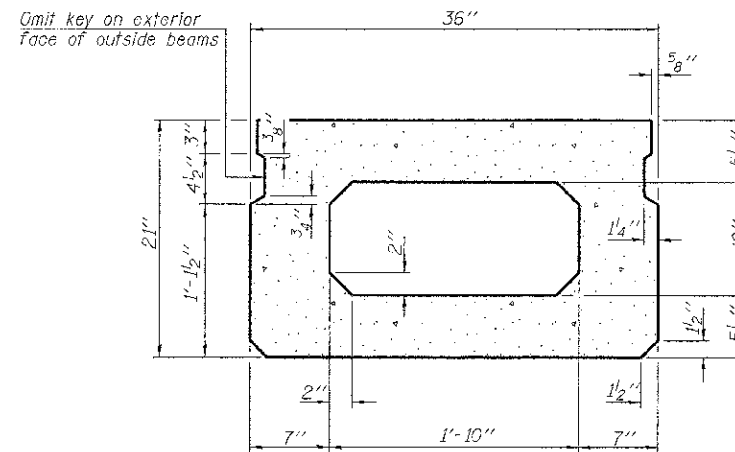

SECTION B-B
(Showing dimensions)

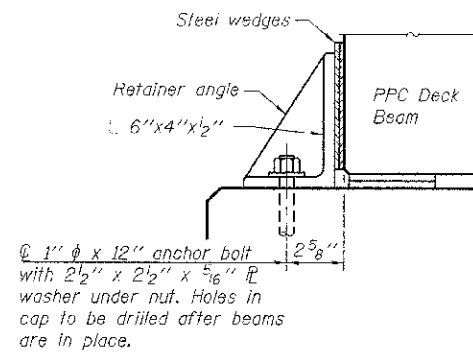

SECTION F-F

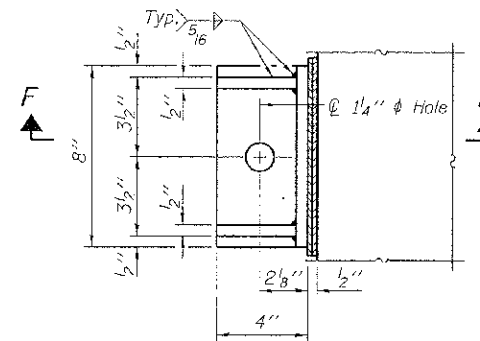

PLAN

Notes:
 Cost of retainer, anchor bolt, and accessories are included with Precast Prestressed Concrete Deck Beams (21" Depth).
 Equivalent rolled angle with stiffeners will be allowed in lieu of welded plates.
 The side retainers shall be galvanized after shop fabrication according to AASHTO M 111 and ASTM 385.
 Anchor bolts and plate washers shall be galvanized according to AASHTO M 232.
 After the notch or concrete overlay are poured and cured, the steel wedges shall be removed.

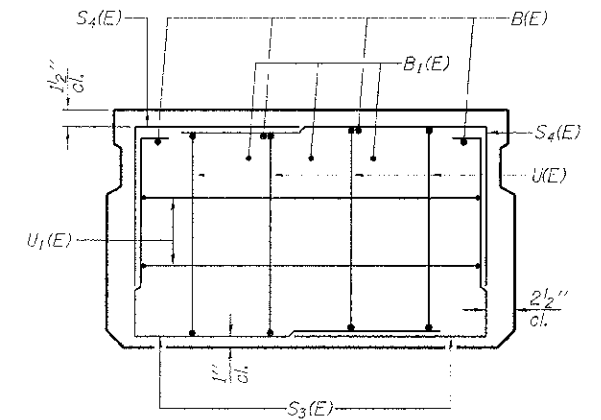

VIEW C-C

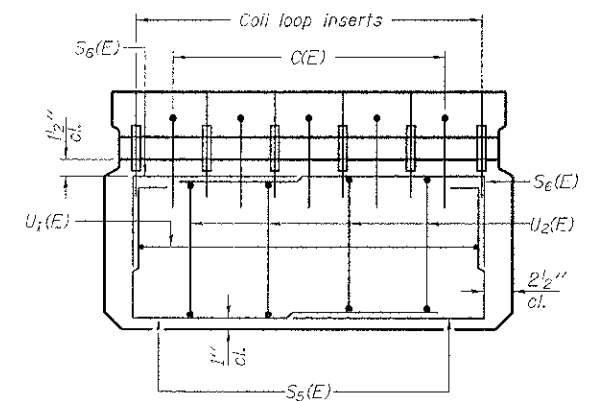

VIEW D-D

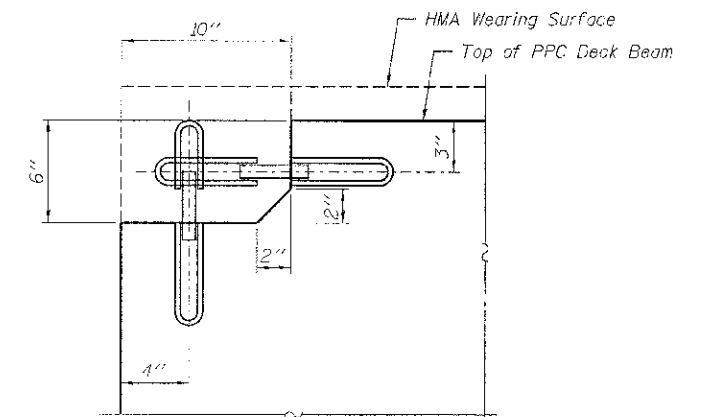

DETAIL A

PD-2136-R

7-1-10

FILE NAME = 120127-ehtr-br1dgn.dgn	USER NAME =	DESIGNED - D.W.T.	REVISED -	STATE OF ILLINOIS DEPARTMENT OF TRANSPORTATION	21" x 36" PPC DECK BEAM - SPANS 1 & 5 STRUCTURE NO. 039-3097	C.P.	SECTION	COUNTY	TOTAL SHEETS	SHEET NO.
HAMPTON, LENZINI AND RENWICK, INC. 302 STEPHENS DRIVE, SUITE 101 SPRINGFIELD, ILLINOIS 62703	PLOT SCALE =	CHECKED - S.W.M.	REVISED -			11	06-00145-00-BR	JACKSON	54	37
CLINCH PROFESSIONAL DESIGN FIRM 12176 138 CORN. - HAMPTON	PLOT DATE = 4/19/2013	DRAWN - D.A.B.	REVISED -			DILLINGER ROAD		CONTRACT NO. 99509		
		CHECKED - S.W.M.	REVISED -			ILLINOIS FED. AID PROJECT				

SHEET NO. 4 OF 21 SHEETS

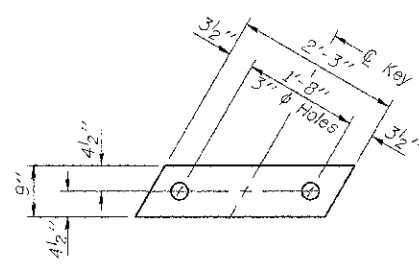

FABRIC BEARING PAD
(Interior - 16 Req'd. - Fixed)
(Interior - 16 Req'd. - Expansion)

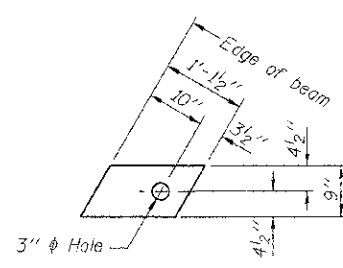

FABRIC BEARING PAD
(Exterior - 4 Req'd. - Fixed)
(Exterior - 4 Req'd. - Expansion)

FIXED

Notes:
All bearing pads shall be 1" thick.
Omit holes when using expansion bearings.
Expansion bearing pad shall be bonded to the substructure.

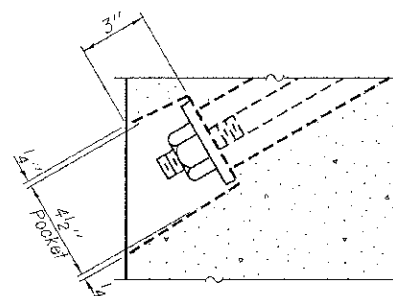

SECTION A-A

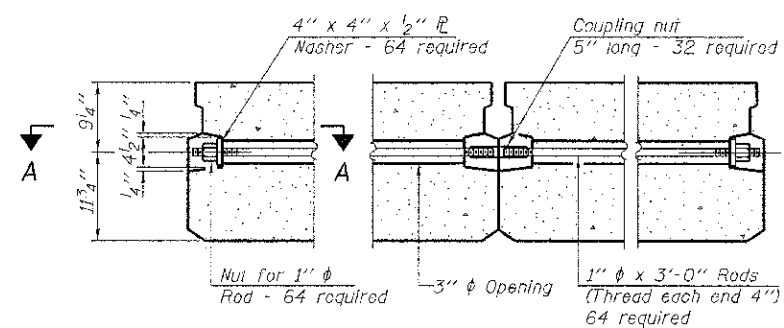

TYPICAL TRANSVERSE TIE ASSEMBLY

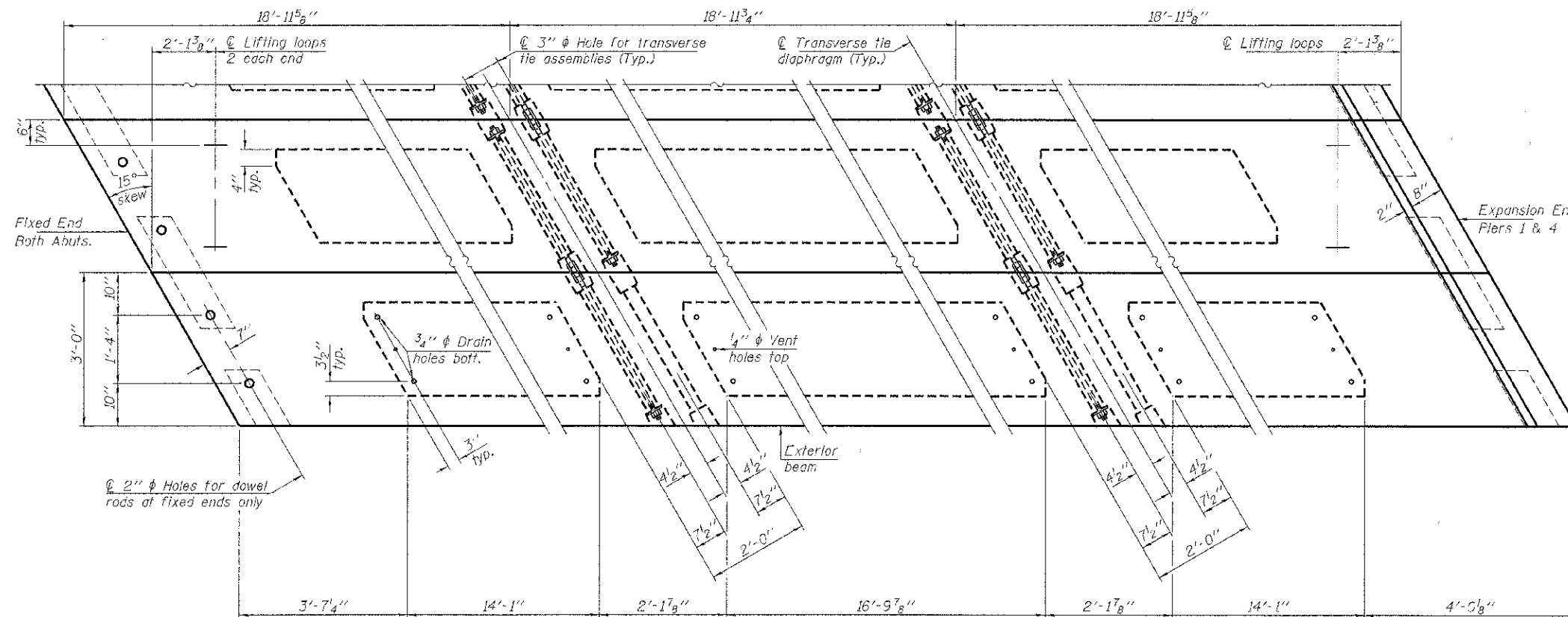

PLAN VIEW

Note: Connect beams in pairs with the transverse tie configuration shown.

NOTES

Prestressing steel shall be uncoated high strength, low relaxation 7-wire strand, Grade 270. The nominal diameter shall be 1/2" and the nominal cross-sectional area shall be 0.153 sq. in. The 1" ϕ rods in the transverse tie assembly shall be tightened to a snug fit and the threads set. Pockets on exterior faces of bridge shall be filled with grout after transverse tie assembly is in place.
Reinforcement bars shall conform to ASTM A 706, Grade 60. (See Special Provisions).
Two 1/8" fabric adjusting shims of the dimensions of the exterior bearing pad shall be provided for each bearing pad location.
A minimum 2 1/2" ϕ lifting pin shall be used to engage the lifting loops during handling.
Corrosion inhibitor, per Article 1020.05(b)(12) and 1021.07 of the Standard Specifications, shall be used in the concrete for precast prestressed concrete deck beams.
Compressive strength of prestressed concrete, f'_c , shall be 6000 psi.
Compressive strength of prestressed concrete at release, f'_{ci} , shall be 5000 psi.
All bars shall be epoxy coated.

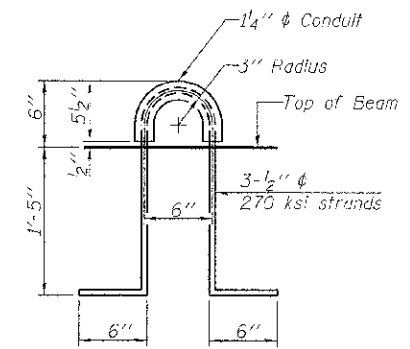

LIFTING LOOP DETAIL

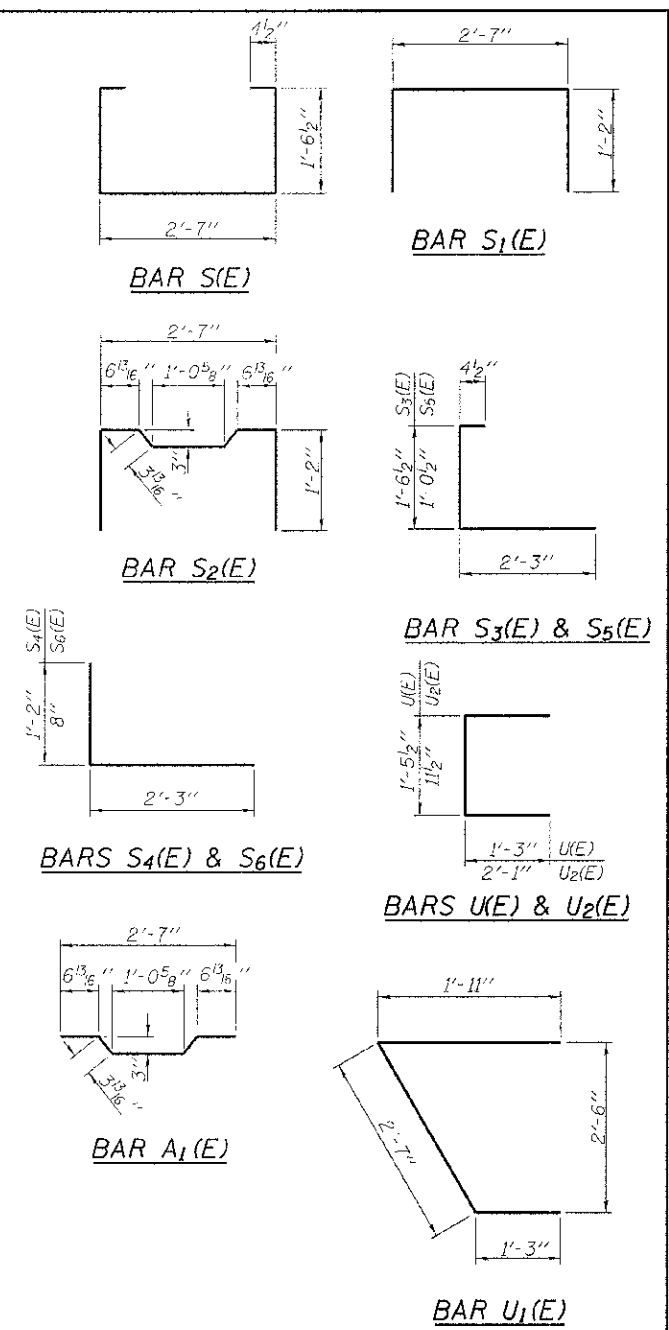

**BILL OF MATERIAL
SPANS 1 & 5**

Material	Sq. Ft.	Quantity
Precast Prestressed Cons. Deck Bms. (21" depth)	Sq. Ft.	3,074
Hot-Mix Asphalt Surface Course, Mix C, N50	Ton	38
Waterproofing Membrane System	Sq. Yd.	341
P.C. Mortar Fairing Course	Foot	225

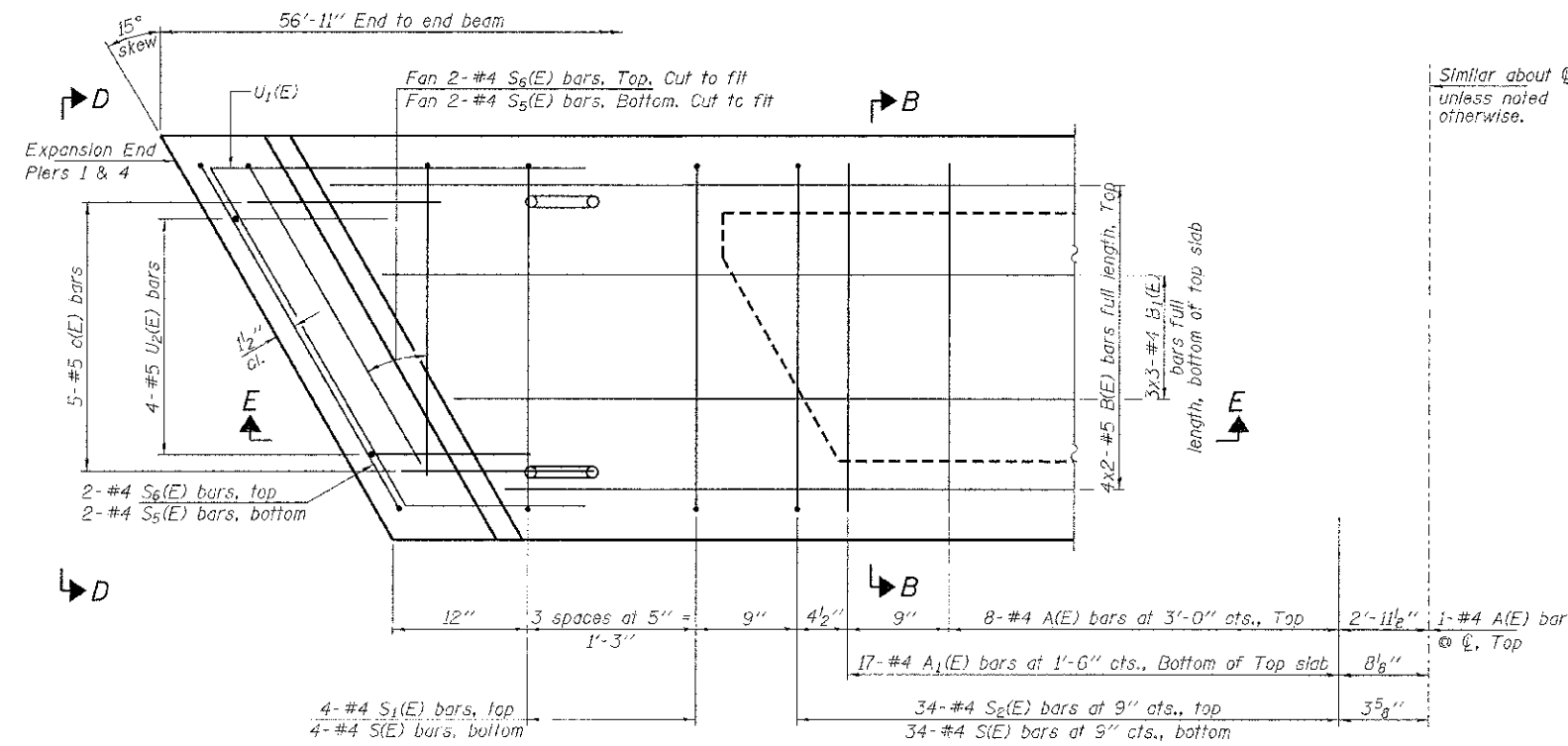

PLAN VIEW

Similar about C unless noted otherwise.

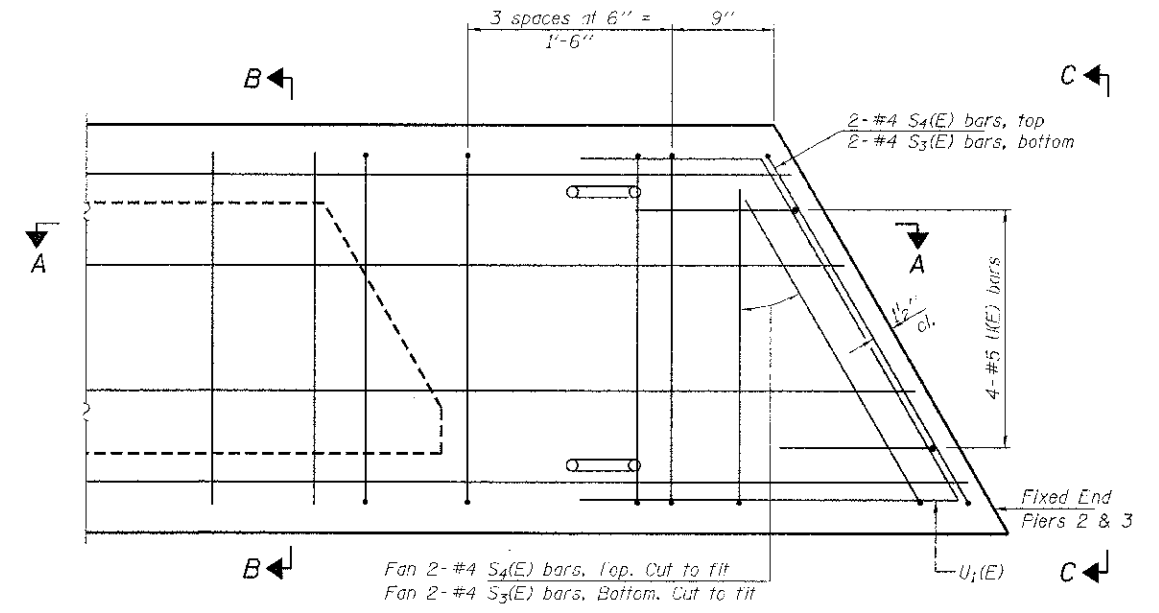

Notes:
Spacing of S(E) and S₂(E) bars may be adjusted up to 4" in the immediate area of the transverse tie diaphragms to miss the block outs for the transverse ties.
Bars indicated thus 4x2-#5 etc. indicates 4 lines of bars with 2 lengths per line.
See sheet 7 of 21 for SECTION A-A, SECTION B-B, VIEW C-C, VIEW D-D & SECTION E-E.

MINIMUM BAR LAP
#4 bar = 2'-0"
#5 bar = 2'-6"

BAR LIST
ONE BEAM ONLY
(For information only)

Bar	No.	Size	Length	Shape
A(E)	17	#4	2'-7"	—
A ₁ (E)	34	#4	2'-10"	—
B(E)	8	#5	29'-7"	—
B ₁ (E)	9	#4	20'-3"	—
C(E)	5	#5	3'-8"	↘
S(E)	76	#4	6'-5"	⌋
S ₁ (E)	8	#4	4'-11"	⌋
S ₂ (E)	68	#4	5'-2"	⌋
S ₃ (E)	4	#4	4'-2"	⌋
S ₄ (E)	4	#4	3'-5"	⌋
S ₅ (E)	4	#4	3'-8"	⌋
S ₆ (E)	4	#4	2'-11"	⌋
U(E)	4	#5	4'-0"	⌋
U ₁ (E)	3	#5	5'-9"	⌋
U ₂ (E)	4	#5	5'-2"	⌋

Note: See sheets 7 & 8 of 21 for additional details and Bill of Material.

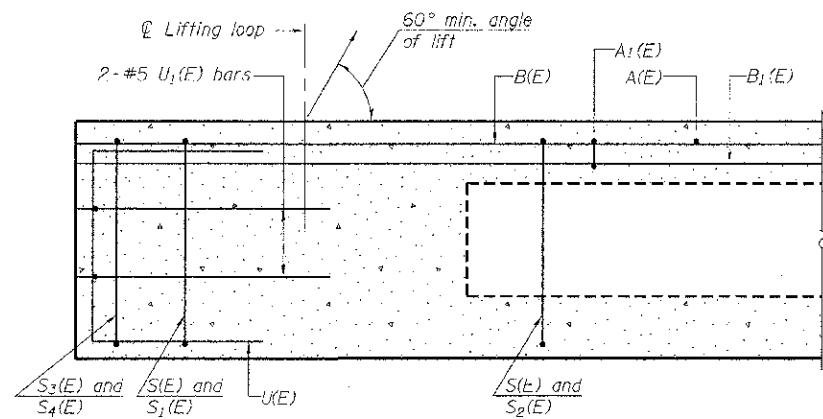

SECTION A-A

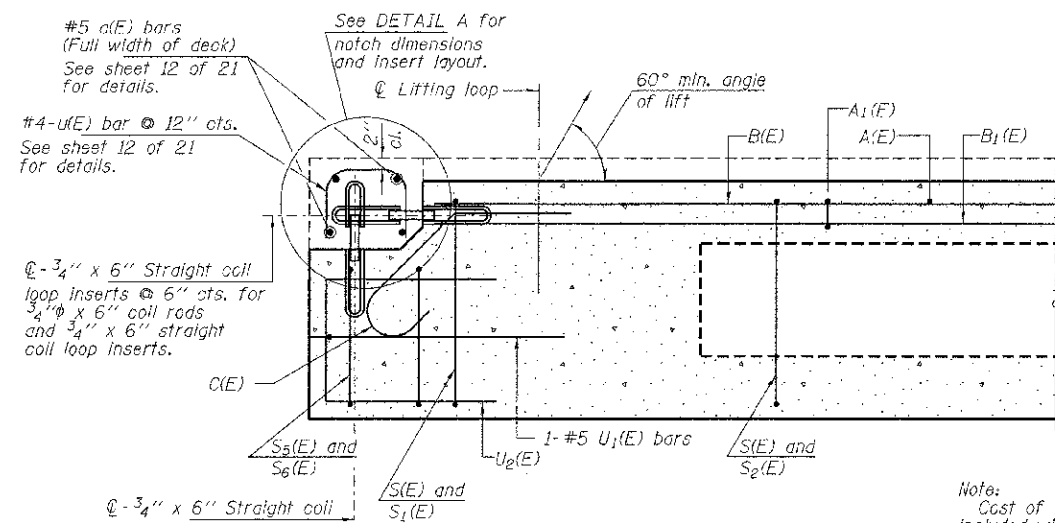

SECTION E-E

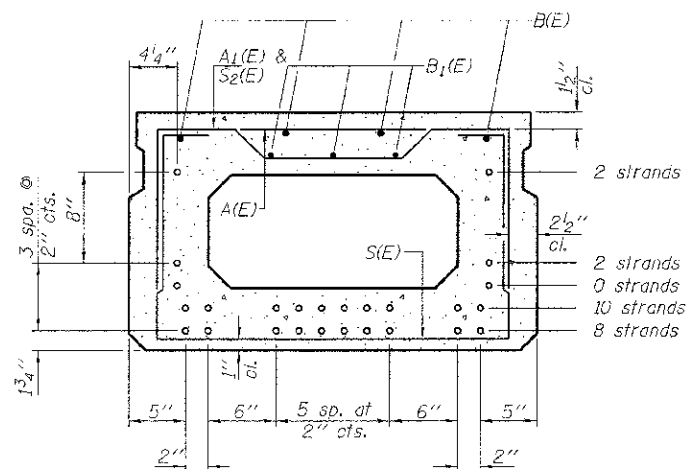

SECTION B-B

(Showing reinforcement and permissible strand locations)

Note: Place the number of strands specified in each row symmetrically about the centerline of beam in the permissible strand locations shown.

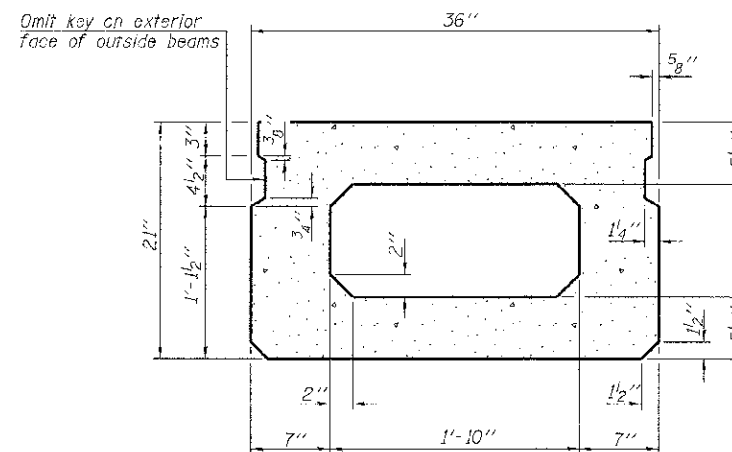

SECTION B-B
(Showing dimensions)

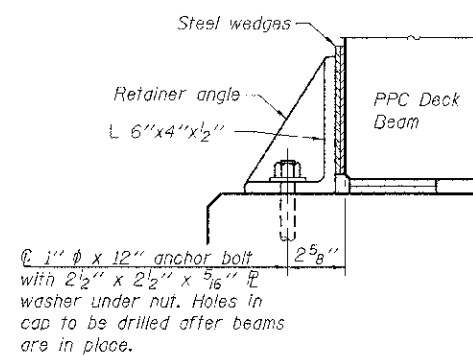

SECTION F-F

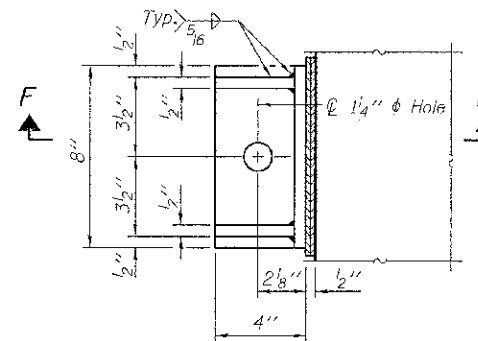

PLAN

Notes:
 Cost of retainer and accessories are included with Precast Prestressed Concrete Deck Beams (21" Depth). Equivalent rolled angle with stiffeners will be allowed in lieu of welded plates.
 The side retainers shall be galvanized after shop fabrication according to AASHTO M 111 and ASTM 385.
 Anchor bolts and plate washers shall be galvanized according to AASHTO M 232.
 After the notch or concrete overlay are poured and cured, the steel wedges shall be removed.

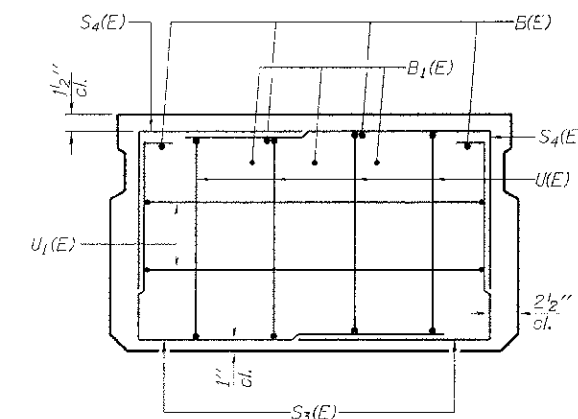

VIEW C-C

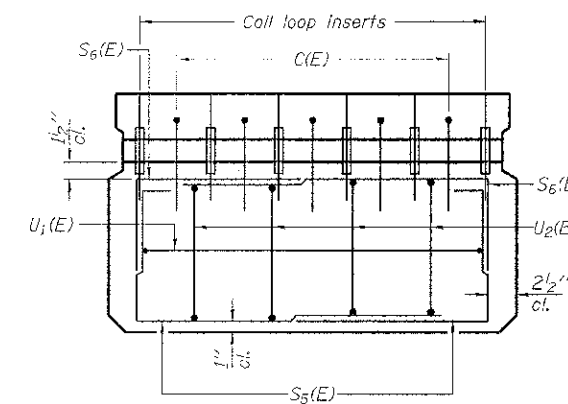

VIEW D-D

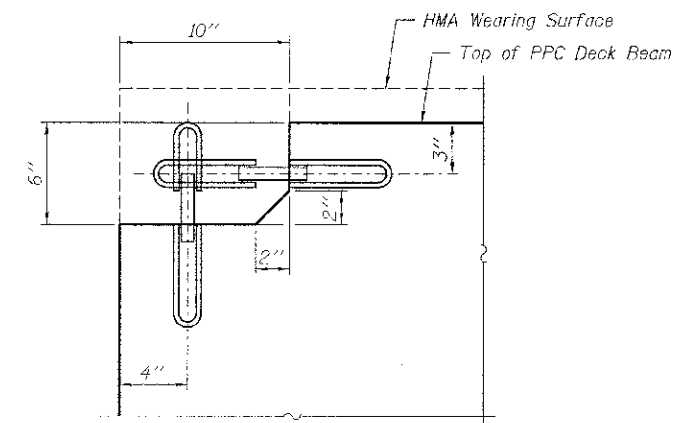

DETAIL A

FILE NAME = 120127-ahb-bridgedgn	USER NAME =	DESIGNED - D.W.T.	REVISED -	STATE OF ILLINOIS DEPARTMENT OF TRANSPORTATION	21" x 36" PPC DECK BEAM - SPANS 2 & 4 STRUCTURE NO. 039-3097	C.H.	SECTION	COUNTY	TOTAL SHEETS	SHEET NO.
HAMPTON, LENZINI AND RENWICK, INC. 555 STEVENSON DRIVE, SUITE 211 SPRING LAKE, ILLINOIS 60173	PLOT SCALE =	CHECKED - S.W.M.	REVISED -			11	06-00145-00-BR	JACKSON	54	40
ILLINOIS PROFESSIONAL DESIGNER FROM SE7/PE/SEC/DMP 14400009	PLOT DATE = 4/3/2013	DRAWN - D.A.B.	REVISED -			DILLINGER ROAD		CONTRACT NO. 99509		
		CHECKED - S.W.M.	REVISED -			SHEET NO. 7 OF 21 SHEETS		ILLINOIS FED. AID PROJECT		

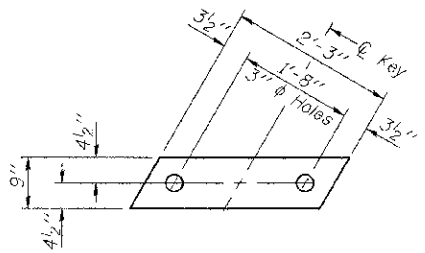

FABRIC BEARING PAD
(Interior - 16 Req'd. - Fixed)
(Interior - 16 Req'd. - Expansion)

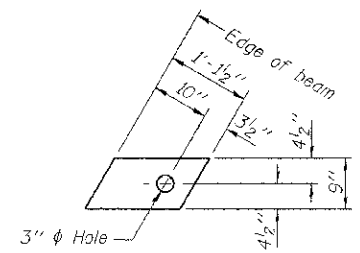

FABRIC BEARING PAD
(Exterior - 4 Req'd. - Fixed)
(Exterior - 4 Req'd. - Expansion)

FIXED
Notes:
All bearing pads shall be 1" thick.
Omit holes when using expansion bearings.
Expansion bearing pad shall be bonded to the substructure.

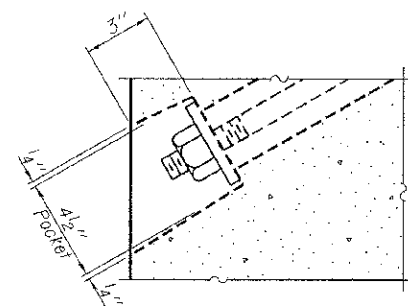

SECTION A-A

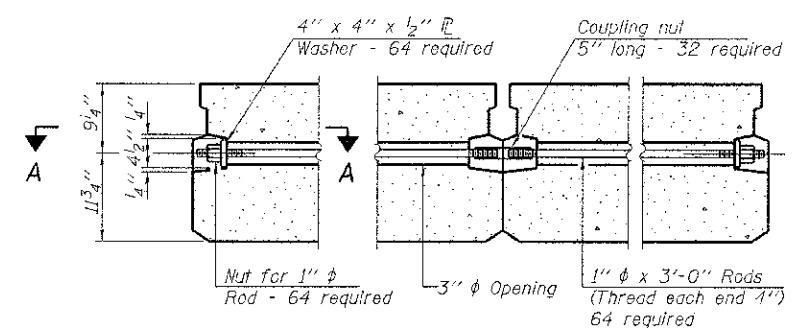

TYPICAL TRANSVERSE TIE ASSEMBLY

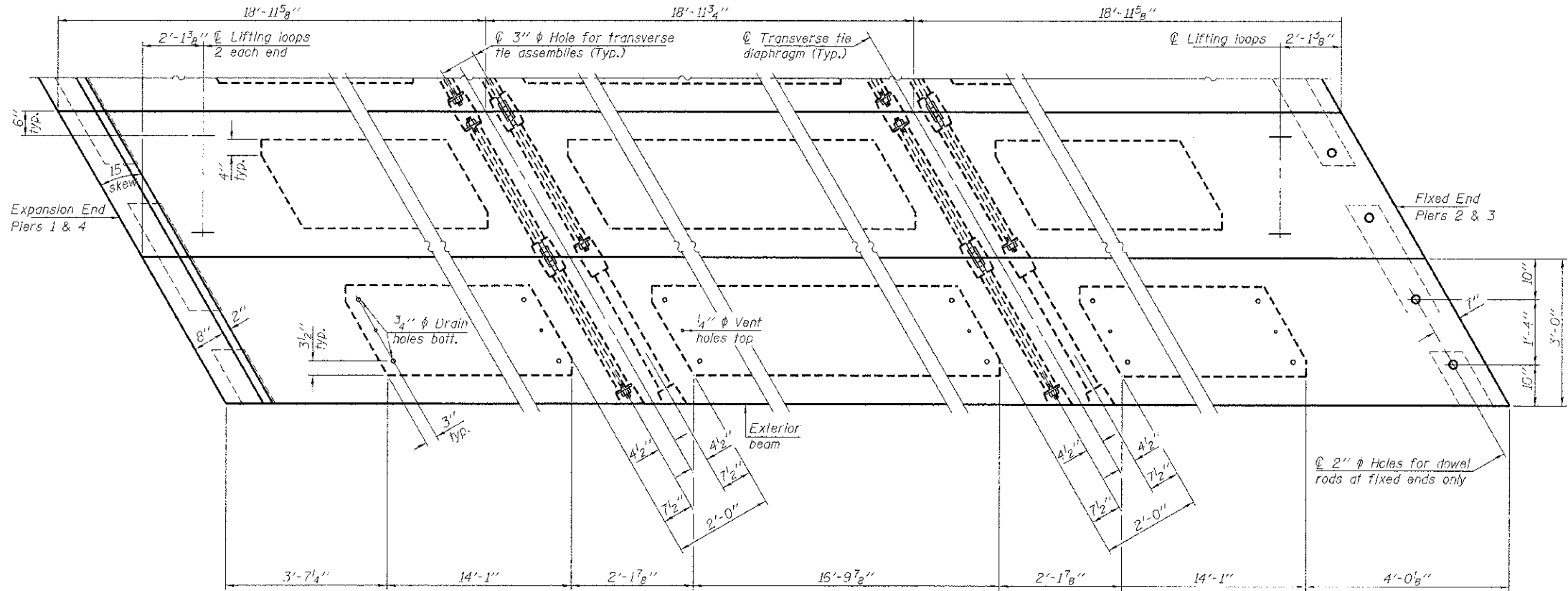

PLAN VIEW

Note: Connect beams in pairs with the transverse tie configuration shown.

NOTES

Prestressing steel shall be uncoated high strength, low relaxation 7-wire strand, Grade 270. The nominal diameter shall be 1/2" and the nominal cross-sectional area shall be 0.153 sq. in. The 1" diameter rods in the transverse tie assembly shall be tightened to a snug fit and the threads set. Pockets on exterior faces of bridge shall be filled with grout after transverse tie assembly is in place. Reinforcement bars shall conform to ASTM A 706, Grade 60. (See Special Provisions). Two 1/8" fabric adjusting shims of the dimensions of the exterior bearing pad shall be provided for each bearing pad location. A minimum 2 1/2" diameter lifting pin shall be used to engage the lifting loops during handling. Corrosion inhibitor, per Article 1020.05(b)(12) and 1021.07 of the Standard Specifications, shall be used in the concrete for precast prestressed concrete deck beams. Compressive strength of prestressed concrete, f'c, shall be 6000 psi. Compressive strength of prestressed concrete at release, f'ci, shall be 5000 psi. All bars shall be epoxy coated.

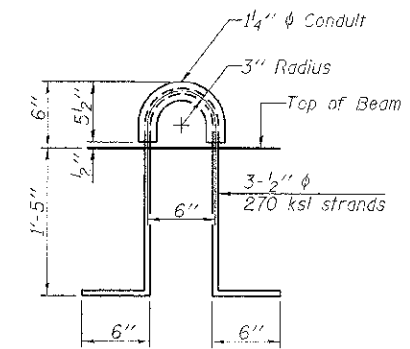

LIFTING LOOP DETAIL

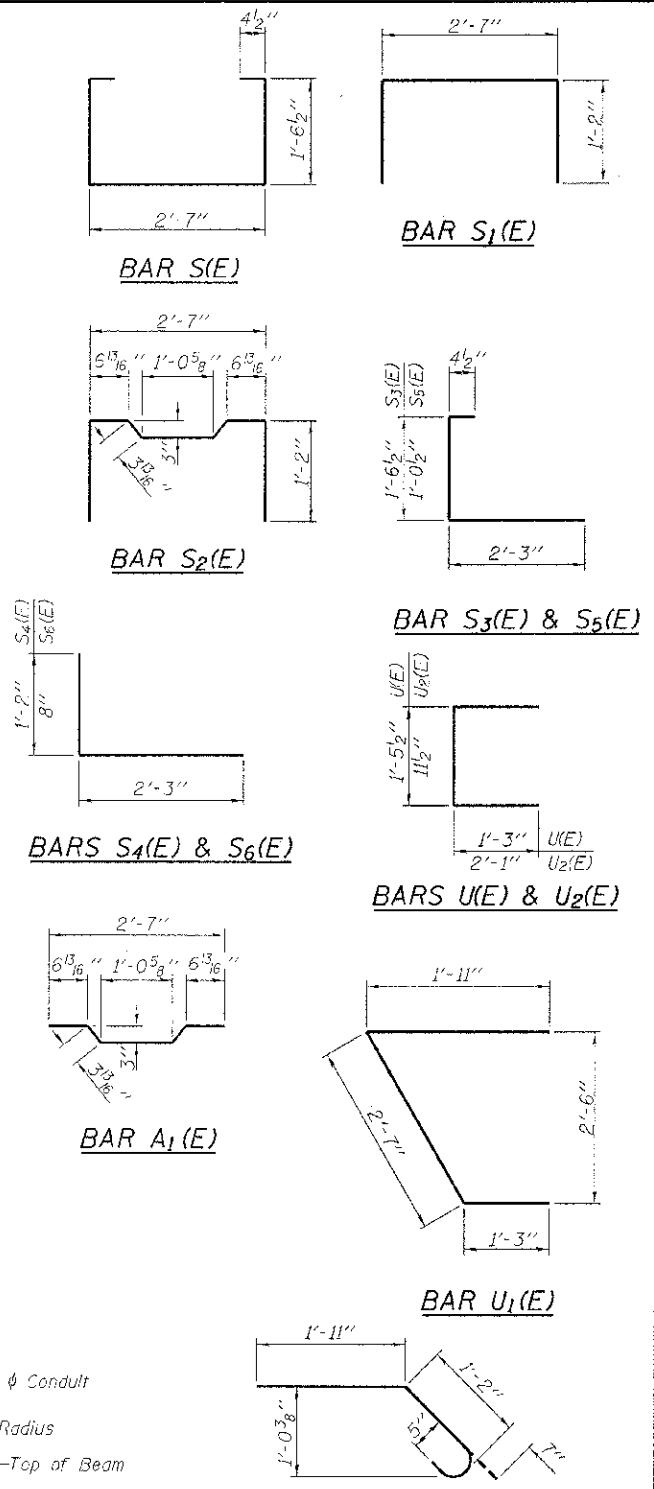

**BILL OF MATERIAL
SPANS 2 & 4**

Precast Prestressed Conc. Deck Bms. (21" depth)	Sq. Ft.	3,074
Hot-Mix Asphalt Surface Course, Mix C, N50	Ton	38
Waterproofing Membrane System	Sq. Yd.	337
P.C. Mortar Fairing Course	Foot	228

FILE NAME = 120127-ent-bridge.dgn	USER NAME =	DESIGNED - D.W.T.	REVISED -
HAMPTON, LENZINI AND RENWICK, INC.		CHECKED - S.W.M.	REVISED -
1110 S. WASHINGTON ST. SUITE 100 SPRINGFIELD, ILLINOIS 62762	PLOT SCALE =	DRAWN - D.A.B.	REVISED -
ILLINOIS PROFESSIONAL DESIGN FIRM LS 174 / IFC CODE: 104.000005	PLOT DATE = 4/9/2013	CHECKED - S.W.M.	REVISED -

**STATE OF ILLINOIS
DEPARTMENT OF TRANSPORTATION**

**21" x 36" PPC DECK BEAM DETAILS - SPANS 2 & 4
STRUCTURE NO. 039-3097**

SHEET NO. 8 OF 21 SHEETS

C.H.	SECTION	COUNTY	TOTAL SHEETS	SHEET NO.
11	06-00145-00-BR	JACKSON	54	41
DELLINGER ROAD			CONTRACT NO. 99509	
ILLINOIS FED. AID PROJECT:				

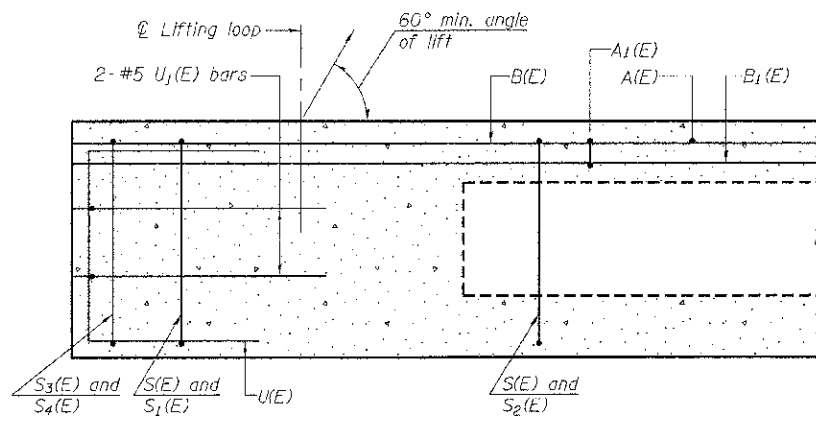

SECTION A-A

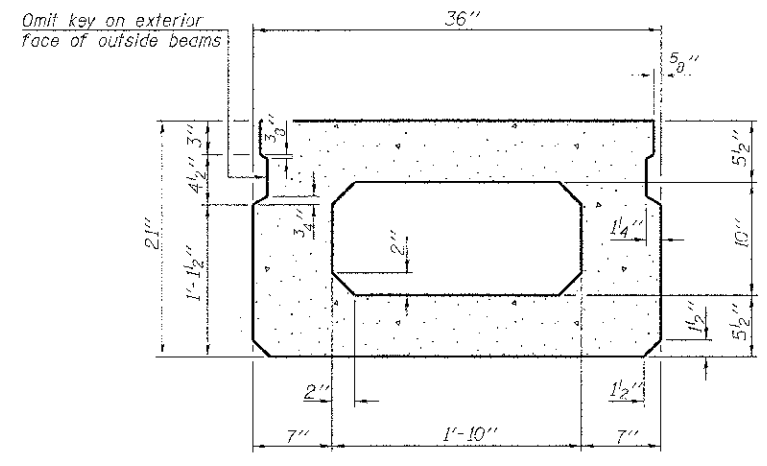

SECTION B-B
(Showing dimensions)

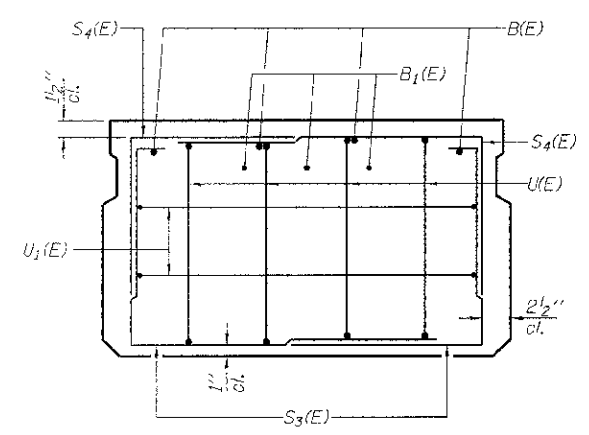

VIEW C-C

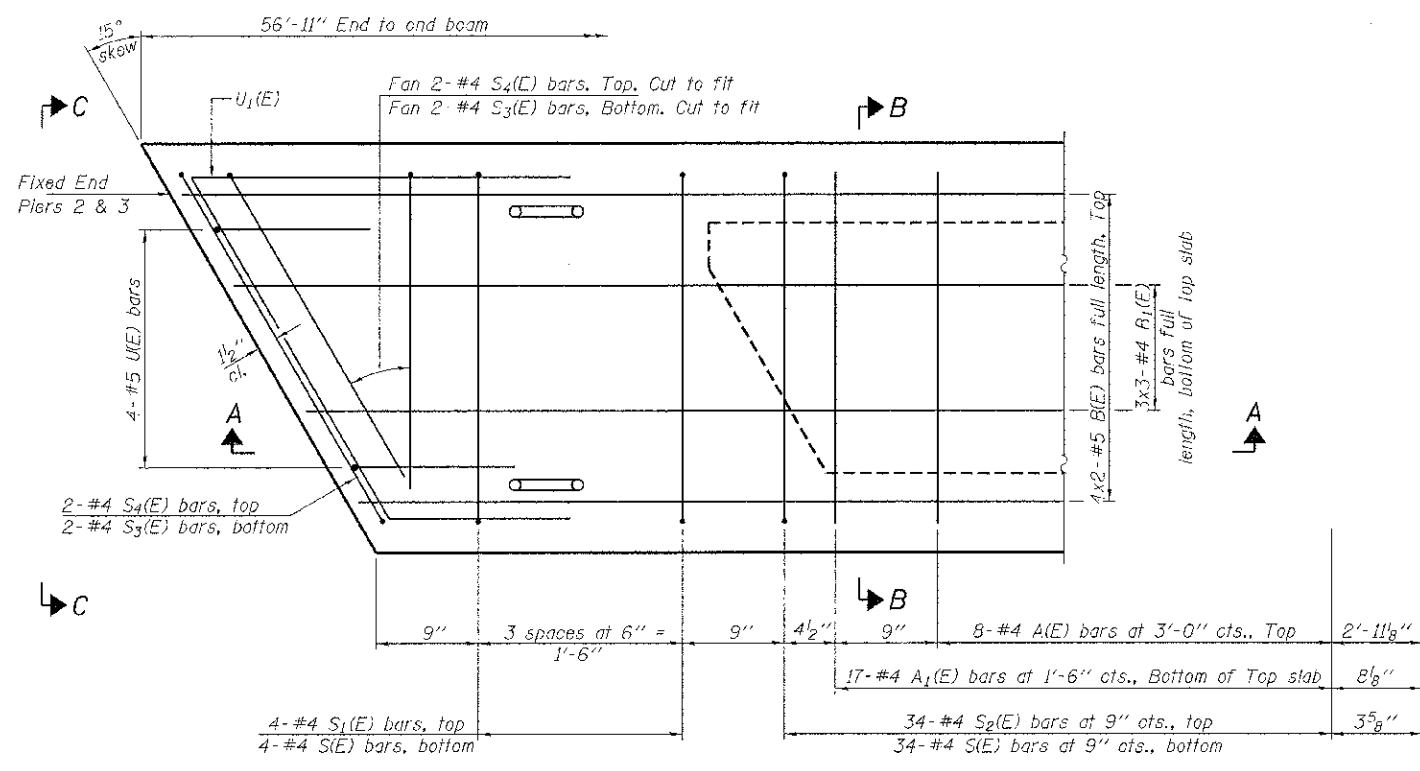

PLAN VIEW

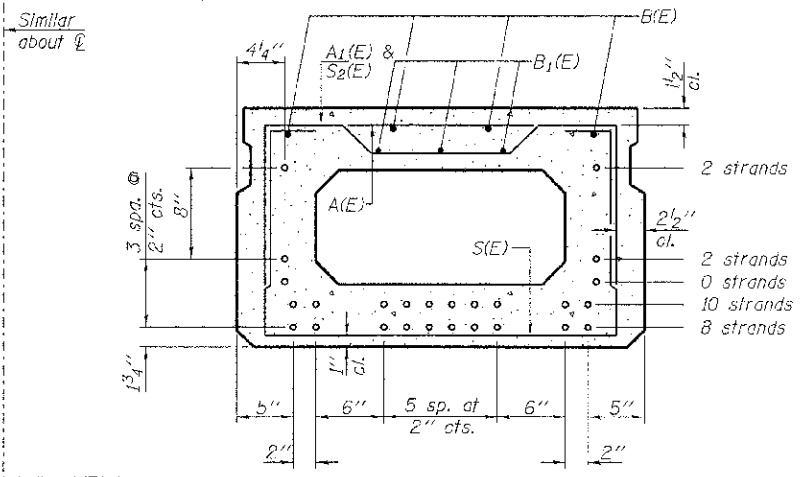

SECTION B-B
(Showing reinforcement and permissible strand locations)

Note: Place the number of strands specified in each row symmetrically about the centerline of beam in the permissible strand locations shown.

BAR LIST
ONE BEAM ONLY
(For information only)

Bar	No.	Size	Length	Shape
A(E)	17	#4	2'-7"	—
A1(E)	34	#4	2'-10"	—
B(E)	8	#5	29'-7"	—
B1(E)	9	#4	20'-3"	—
S(E)	76	#4	6'-5"	□
S1(E)	8	#4	4'-11"	□
S2(E)	68	#4	5'-2"	□
S3(E)	8	#4	4'-2"	□
S4(E)	8	#4	3'-5"	□
U(E)	8	#5	4'-0"	□
U1(E)	4	#5	5'-9"	□

Note: See sheet 10 of 21 for additional details and Bill of Material.

Notes:
Spacing of S(E) and S2(E) bars may be adjusted up to 4" in the immediate area of the transverse tie diaphragms to miss the block outs for the transverse ties.
Bars indicated thus 4x2-#5 etc. indicates 4 lines of bars with 2 lengths per line.

MINIMUM BAR LAP
#4 bar = 2'-0"
#5 bar = 2'-6"

PD-2136-R 7-1-10

FILE NAME = 120127-sh1-bridge.dgn	USER NAME =	DESIGNED - D.W.T.	REVISED -
HAMPTON, LENZINI AND RENWICK, INC.		CHECKED - S.W.M.	REVISED -
3003 STEVENSON DRIVE SUITE 201 SPRINGFIELD, ILLINOIS 62761	PLOT SCALE =	DRAWN - D.A.B.	REVISED -
ILLINOIS PROFESSIONAL DESIGN PERM LA 178 / 88 CORP. TEL 000809	PLOT DATE = 4/9/2013	CHECKED - S.W.M.	REVISED -

STATE OF ILLINOIS
DEPARTMENT OF TRANSPORTATION

21" x 36" PPC DECK BEAM - SPAN 3
STRUCTURE NO. 039-3097

SHEET NO. 9 OF 21 SHEETS

C.H.	SECTION	COUNTY	TOTAL SHEETS	SHEET NO.
11	06-00145-00-3R	JACKSON	54	42
DILLINGER ROAD		CONTRACT NO. 99509		
ILLINOIS FED. AID PROJECT				

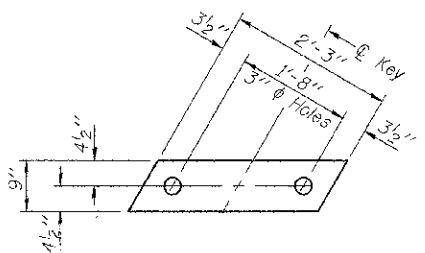

FABRIC BEARING PAD
(Interior - 16 Req'd.)

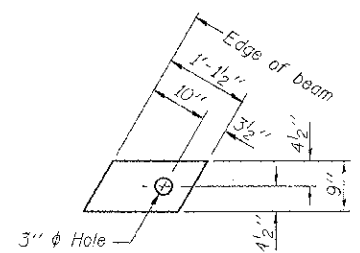

FABRIC BEARING PAD
(Exterior - 4 Req'd.)

FIXED
Notes:
All bearing pads shall be 1" thick.
Omit holes when using expansion bearings.
Expansion bearing pad shall be bonded to the substructure.

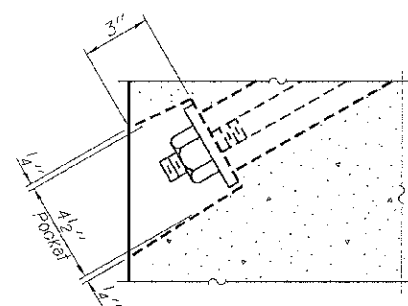

SECTION A-A

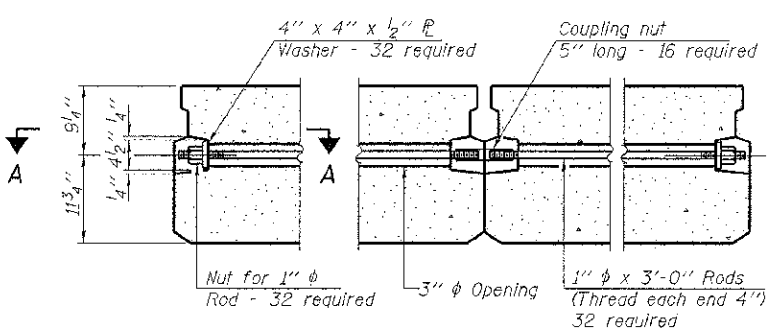

TYPICAL TRANSVERSE TIE ASSEMBLY

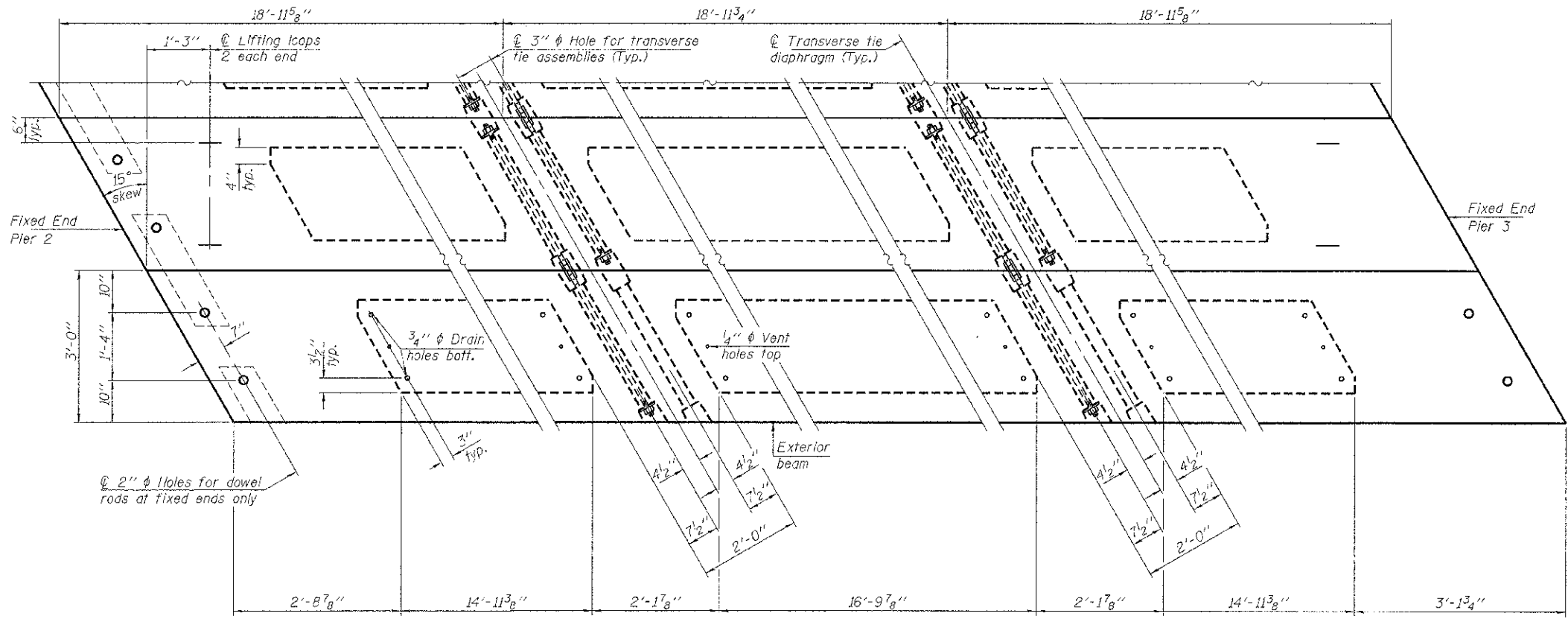

PLAN VIEW

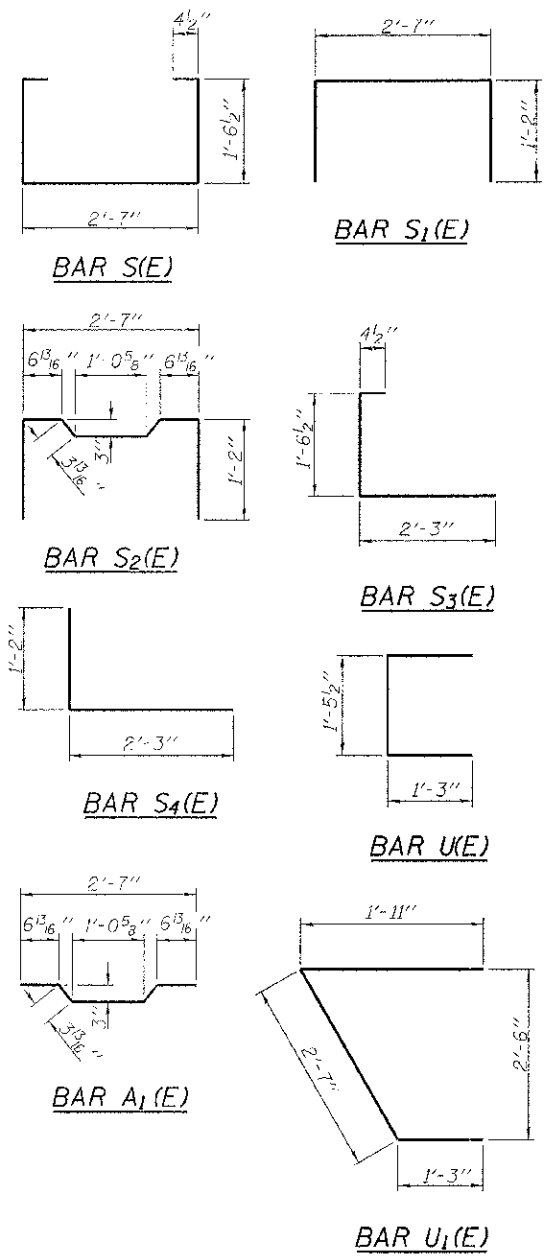

NOTES

Prestressing steel shall be uncoated high strength, low relaxation 7-wire strand, Grade 270. The nominal diameter shall be 1/2" and the nominal cross-sectional area shall be 0.153 sq. in. The 1" rods in the transverse tie assembly shall be tightened to a snug fit and the threads set. Pockets on exterior faces of bridges shall be filled with grout after transverse tie assembly is in place.
Reinforcement bars shall conform to ASTM A 706, Grade 60. (See Special Provisions).
Two 1/2" fabric adjusting shims of the dimensions of the exterior bearing pad shall be provided for each bearing pad location.
A minimum 2 1/2" lifting pin shall be used to engage the lifting loops during handling.
Corrosion inhibitor, per Article 1020.05(b)(12) and 1021.07 of the Standard Specifications, shall be used in the concrete for precast prestressed concrete deck beams.
Compressive strength of prestressed concrete, f'c, shall be 6000 psi.
Compressive strength of prestressed concrete at release, f'ci, shall be 5000 psi.
All bars shall be epoxy coated.

Note: Connect beams in pairs with the transverse tie configuration shown.

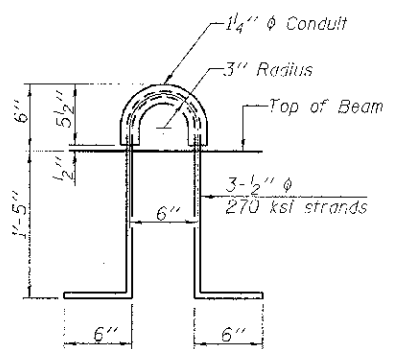

LIFTING LOOP DETAIL

BILL OF MATERIAL - SPAN 3

Material	Unit	Quantity
Precast Prestressed Conc. Deck Bms. (21" depth)	Sq. Ft.	1,537
Hot-Mix Asphalt Surface Course, Mix C, N50	Ton	19
Waterproofing Membrana System	Sq. Yd.	171
P.C. Mortar Fairing Course	Foot	114

PD-2136-RD 7-1-10

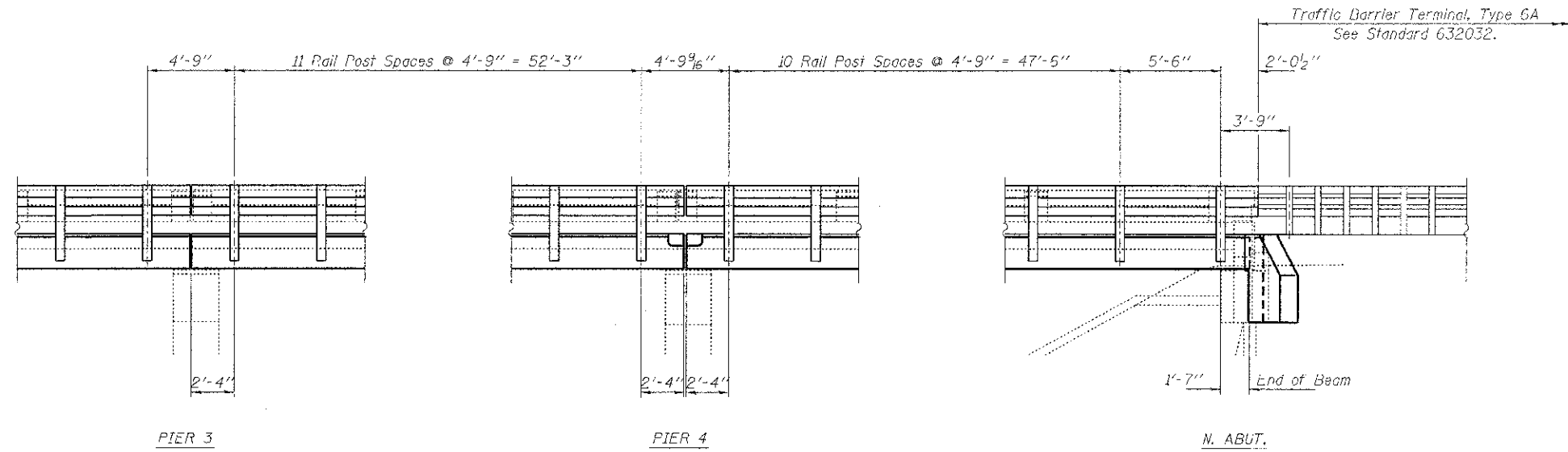
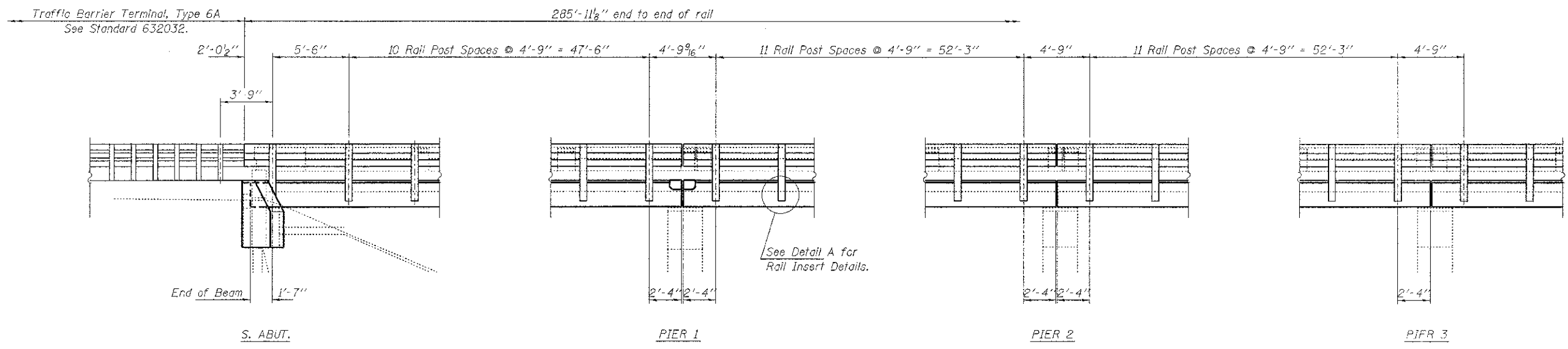

ELEVATION
Showing Rail Post Spaces

See sheet 13 of 21 for Railing Details.

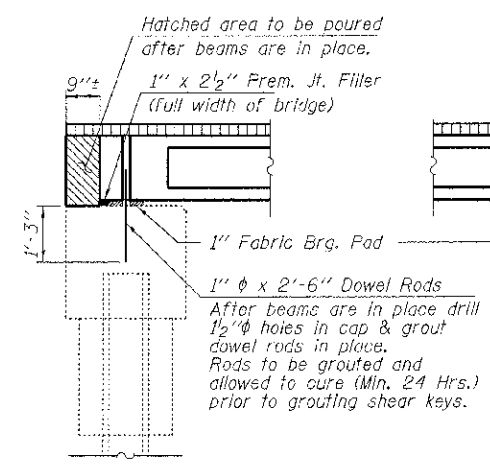

SECTION AT ABUTMENTS
@ Rt. L's

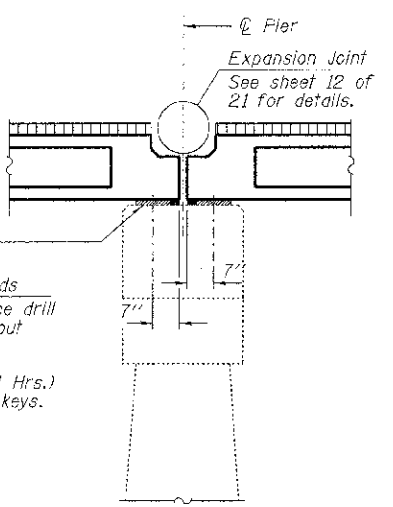

SECTION AT PIERS 1 & 4
@ Rt. L's

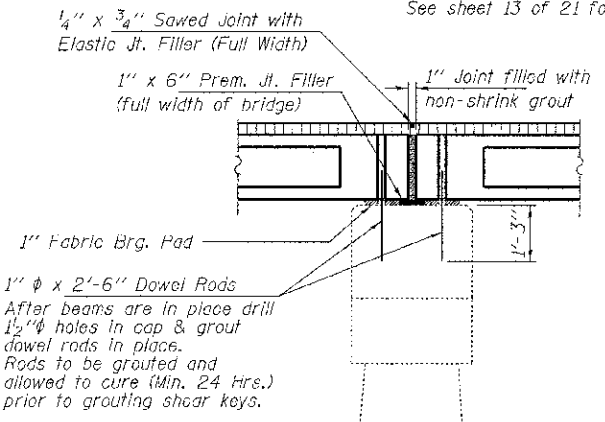

SECTION AT PIERS 2 & 3
@ Rt. L's

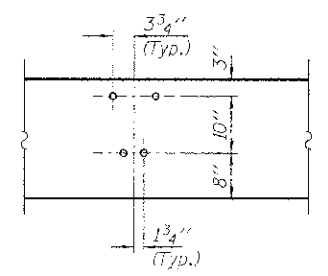

DETAIL A

FILE NAME = 128127-ahv-br-bridge.dgn	USER NAME =	DESIGNED - D.W.T.	REVISED -	STATE OF ILLINOIS DEPARTMENT OF TRANSPORTATION	SUPERSTRUCTURE DETAILS STRUCTURE NO. 039-3097	C.V.L. SECTION	COUNTY	TOTAL SHEETS	SHEET NO.	
HAMPTON, LENZINI AND RENWICK, INC. 300 STEVENSON DRIVE, SUITE 201 SPRINGFIELD, ILLINOIS 62760	PLD.Y SCALE =	CHECKED - S.W.M.	REVISED -			11	06-00145-00-BR	JACKSON	54	44
ILLINOIS PROFESSIONAL ENGINEER FIRM 501 PEERLESS CENTER, NOKIA CENTER	PLOT DATE = 4/9/2013	DRAWN - D.A.B.	REVISED -			DILLINGER ROAD CONTRACT NO. 99509				
		CHECKED - S.W.M.	REVISED -			ILLINOIS FED. AID PROJECT				
SHEET NO. 11 OF 21 SHEETS										

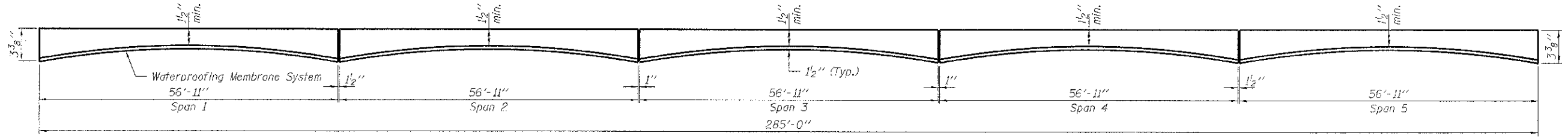

ANTICIPATED HMA WEARING SURFACE PROFILE
 (For information only - beam camber may vary in field.)

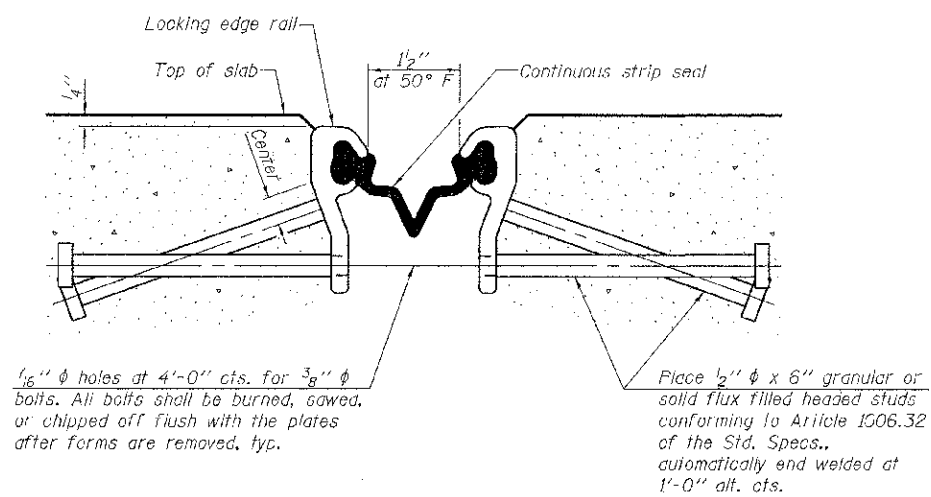

SECTION THRU STRIP SEAL JOINT FOR OVERLAY OVER DECK BEAMS

See sheet 13 of for complete rail details.

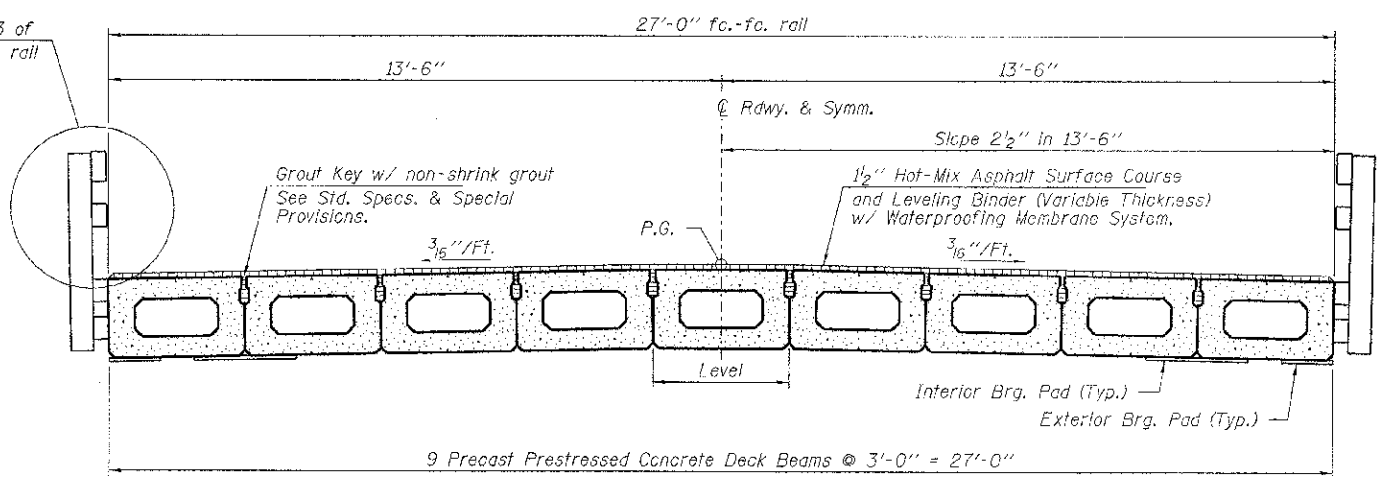

CROSS SECTION

See sheets 3 thru 10 of 21 for Superstructure.

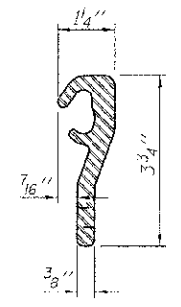

ROLLED (EXTRUDED) RAIL

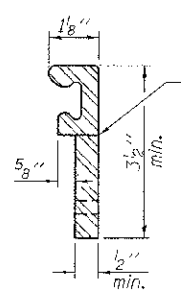

WELDED RAIL

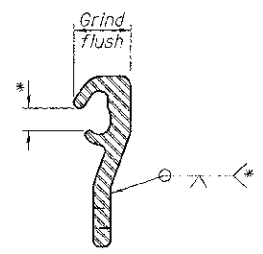

LOCKING EDGE RAIL SPLICE

Rolled rail shown, welded rail similar.

- * Omit weld at seal opening.
- ** The minimum dimension shall be 1/2 inch for installation purposes.
- *** Back gouge not required if complete joint penetration is verified by mock-up.

Notes:

The strip seal shall be made continuous and shall have a minimum thickness of 1/4 inch. The configuration of the strip seal shall match the configuration of the Locking Edge Rails.
 The height and thickness of the Locking Edge Rails shown are minimum dimensions. The actual configuration of the Locking Edge Rails and matching strip seal may vary from manufacturer to manufacturer. Flanged edge rails will not be allowed.
 The inside of the Locking Edge Rail groove shall be free of weld residue.
 Locking Edge Rails may be spliced at slope discontinuities and stage construction joints.
 The manufacturer's recommended installation methods shall be followed.
 All steel components shall be galvanized after fabrication according to Article 520.03 of the Standard Specifications.
 Maximum space between rail segments at stage lines shall be 3/16 inch, sealed with a suitable sealant.

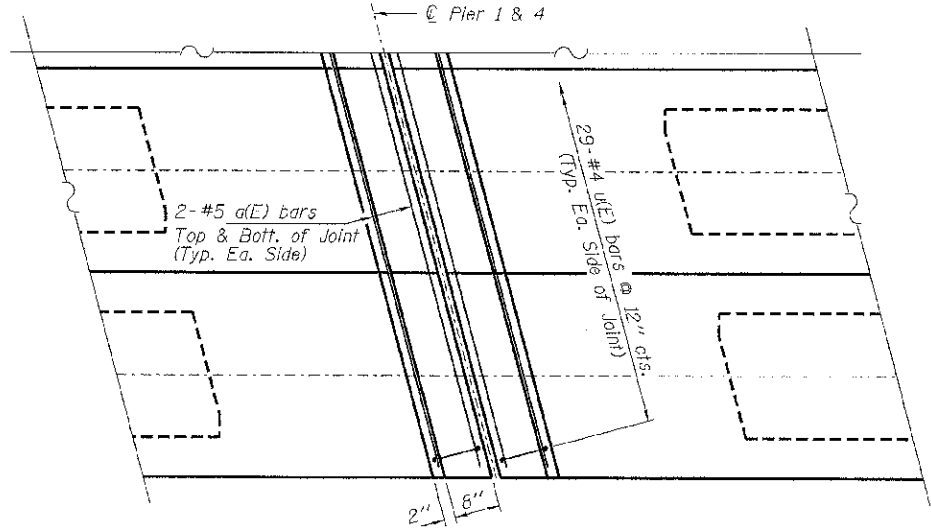

PLAN

(Typ. Expansion Joint at Piers 1 & 4)

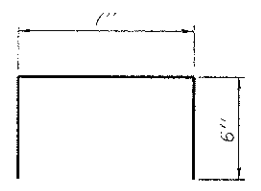

BAR u(E)

BILL OF MATERIAL

BAR	NO.	SIZE	LENGTH	SHAPE
a(E)	16	#5	27'-1"	—
u(E)	116	#4	1'-7"	U
Concrete Superstructures			Cu. Yd.	2.6
Reinforcement Bars, Epoxy Coated			Pound	580
Preformed Joint Strip Seal			Foot	56

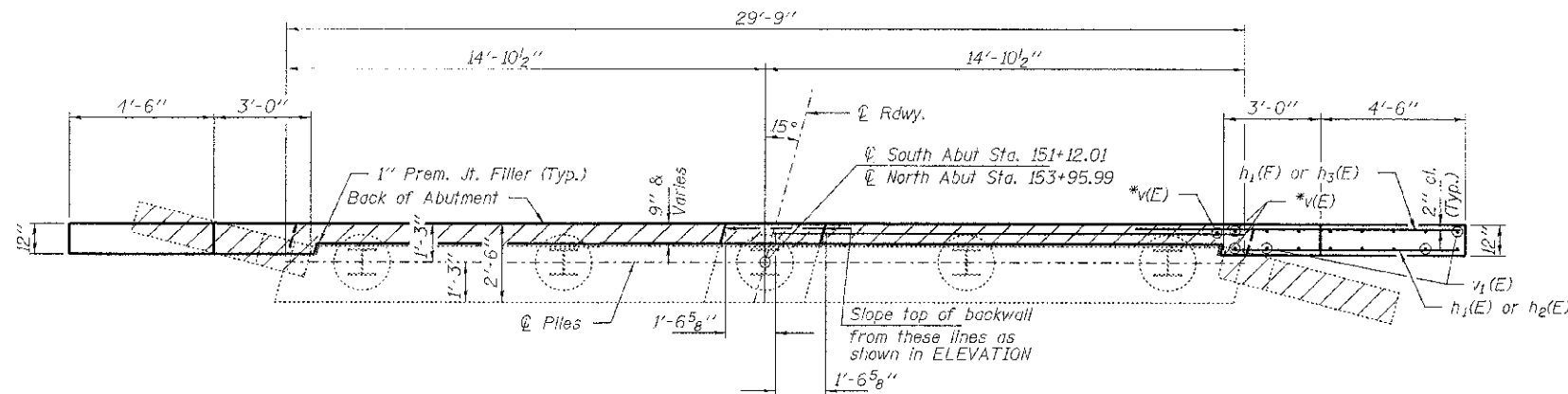

PLAN

Concrete Removal area

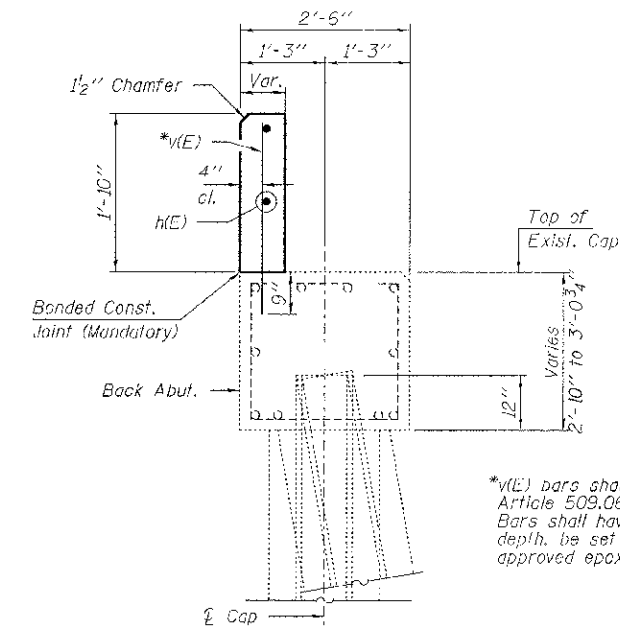

SECTION A-A

Proposed backwall to be poured after beams are in place.

*v(E) bars shall be drilled and set according to Article 509.06 of the Standard Specifications. Bars shall have a 9" minimum embedment depth, be set in 1" holes and filled with approved epoxy grout.

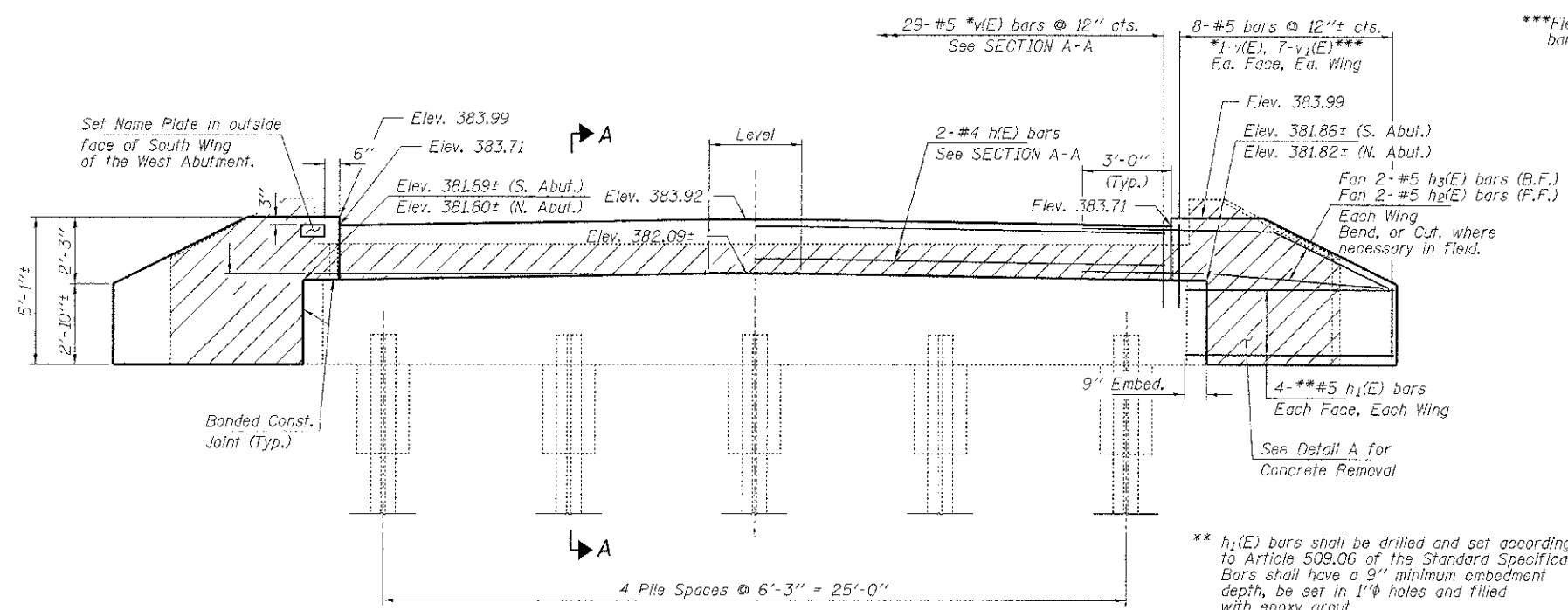

ELEVATION

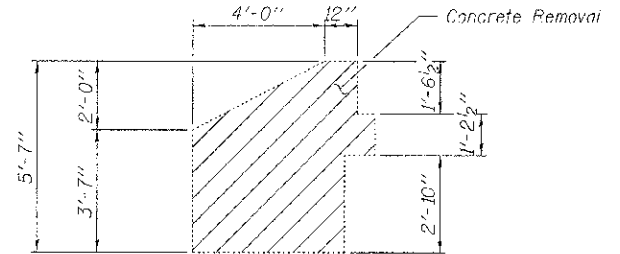

EXISTING WINGWALL DETAIL A

Notes:
 The contractor shall repair, at his own expense, any damage to the substructure caused by removal operations.
 Cost of drilling and grouting reinforcing bars included in cost for Concrete Structures.
 Structural Repair of Concrete shall be used to repair existing deterioration to the abutment as directed by the Engineer.
 Existing wingwall reinforcement which extends into the abutment cap shall be burned off flush with surface, ground smooth, and sealed with epoxy. Cost included with Concrete Removal.
 Backwall and wingwalls shall be poured after the beams are in place.

BILL OF MATERIAL - 2 ABUTS.

BAR	NO.	SIZE	LENGTH	SHAPE	
h(E)	4	#5	29'-6"	---	
h ₁ (F)	32	#5	7'-6"	---	
h ₂ (L)	8	#5	7'-8"	---	
h ₃ (L)	8	#5	11'-0"	---	
v(E)	66	#5	2'-5"	---	
v ₁ (E)	56	#5	4'-8"	---	
Concrete Structures				Cu. Yd.	7.4
Reinforcement Bars, Epoxy Coated				Pound	960
Concrete Sealer				Sq. Ft.	104
Concrete Removal				Cu. Yd.	6.0
Structural Repair of Concrete (Depth equal to or less than 5')				Sq. Ft.	20
Name Plates				Each	1

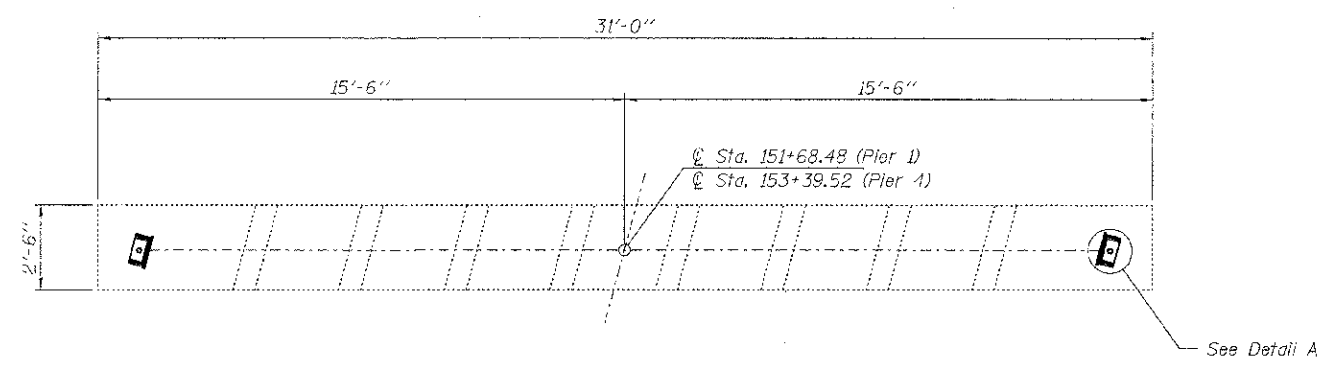

PLAN-PIERS 1 & 4

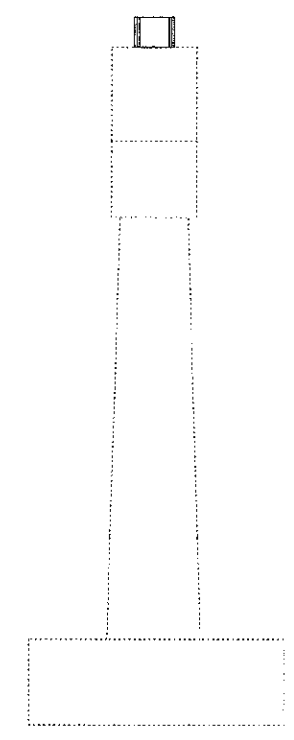

END ELEVATION-PIERS 1 & 4
(Looking East)

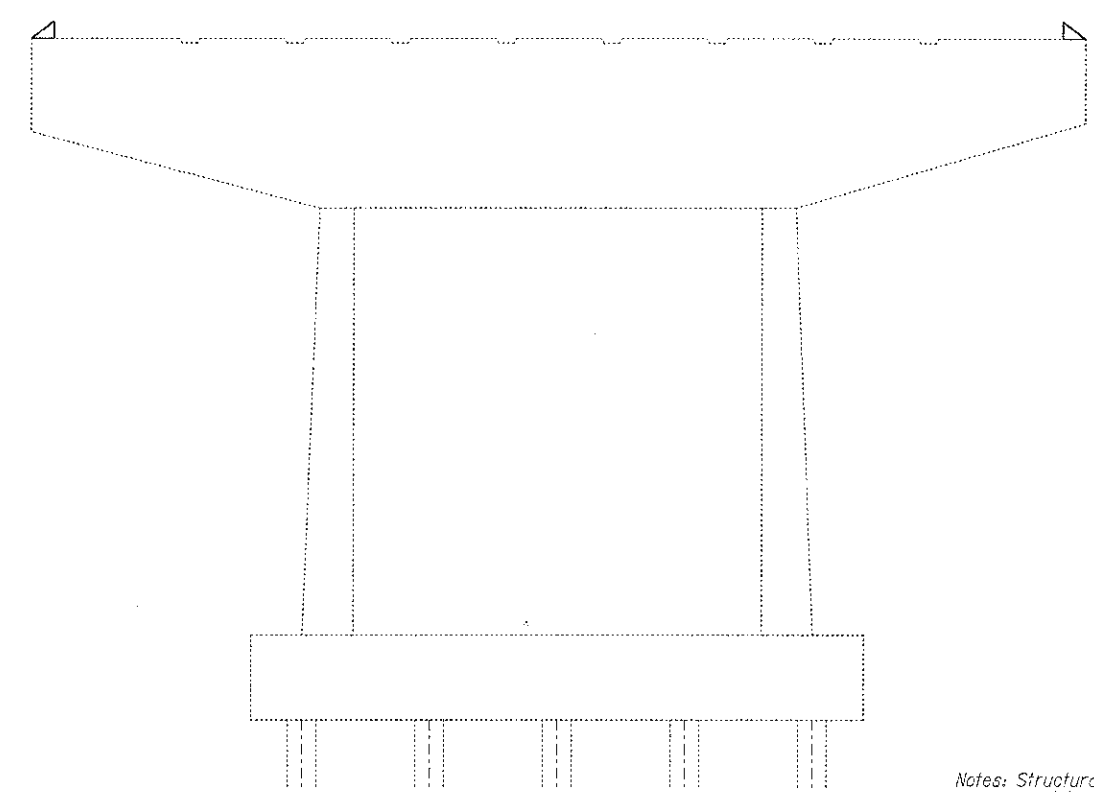

ELEVATION-PIERS
(Looking South)

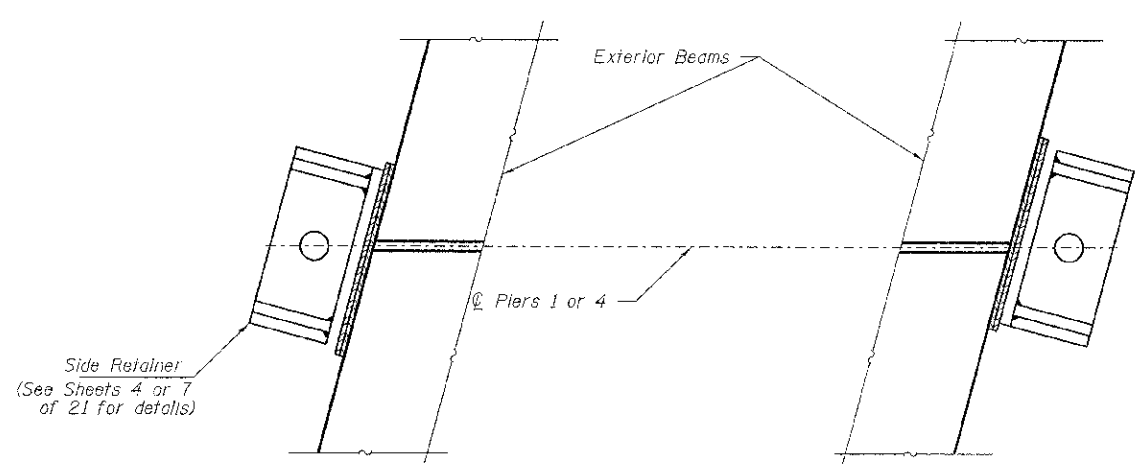

DETAIL A
Piers 1 & 4 only

Notes: Structural repair of concrete shall be used to repair existing deterioration to the piers as directed by the Engineer.
Cost of drilling and adding anchor bolts for side retainers at Piers 1 & 4 is included with cast for Precast Prestressed Concrete Deck Beams (20" Depth)

BILL OF MATERIAL - PIERS

Structural Repair of Concrete (Depth equal to or less than 5")	Sq. Ft.	40
--	---------	----

FILE NAME = 20127-441-brsage.dgn	USER NAME =	DESIGNED - D.W.T.	REVISED -	STATE OF ILLINOIS DEPARTMENT OF TRANSPORTATION	PIERS STRUCTURE NO. 039-3097	C-1	SECTION	COUNTY	TOTAL SHEETS	SHEET NO.
HAMPTON, LENZINI AND RENWICK, INC.		CHECKED - S.W.M.	REVISED -			11	06-00145-00-8R	JACKSON	54	48
JAMES STEPHENSON DATE: 2/8/13 SPRINGFIELD, ILLINOIS 62703	PLOT SCALE =	DRAWN - D.A.B.	REVISED -			DILLINGER ROAD		CONTRACT NO. 99509		
ILR ILLINOIS PROFESSIONAL DESIGN FIRM 167 P.E. / 58 CORP. 18400149	PLOT DATE = 4/9/2013	CHECKED - S.W.M.	REVISED -			SHEET NO. 15 OF 21 SHEETS		[ILLINOIS] FED. AID PROJECT		

B.M. S.W. corner of sandstone abutment
south end exist bridge Rt. Sta. 153+00
Elev. 374.40
Existing Structure - Thru truss on closed
masonry abutts., 14' rdwy.
Cntr. shall remain
offer and new
drivage shall be
in place property
Jackson Co.

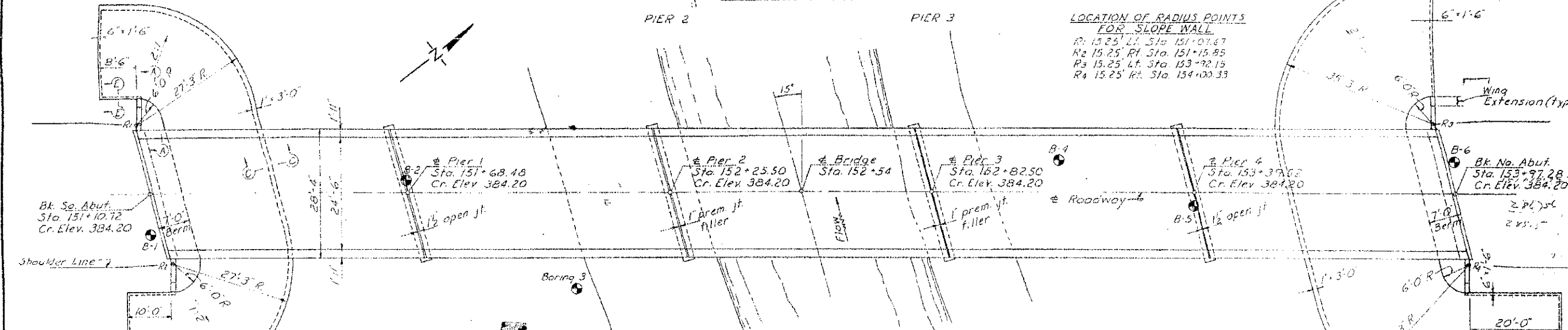
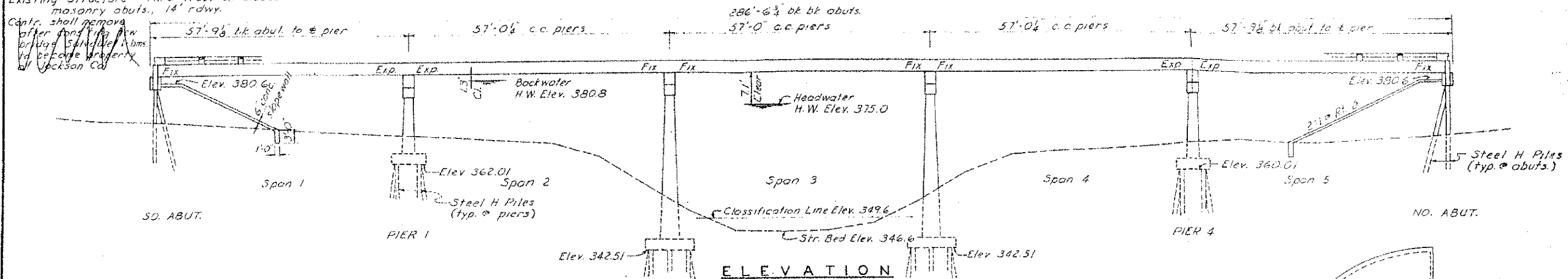

LOCATION OF RADIUS POINTS
FOR SLOPE WALL
R1 15.25 Lf. Sta. 151+07.67
R2 15.25 Rf. Sta. 151+15.85
R3 15.25 Lf. Sta. 153+92.15
R4 15.25 Rf. Sta. 154+00.33

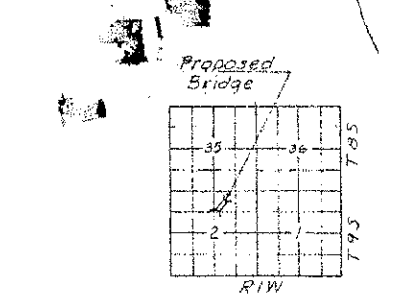
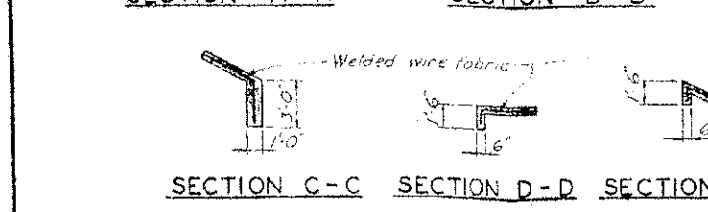
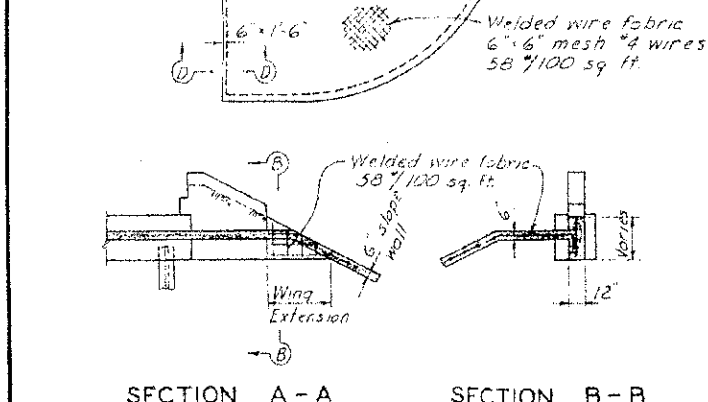

STATION 152+54
CRAB ORCHARD CREEK
SEC. 104B-TR BUILT 19
CARBONDALE RD. DIST.
JACKSON COUNTY
LOADING HS.15

LETTERING FOR NAME PLATE
See 910 211-1

WATERWAY DATA
Drainage Area 163,000 acres
Req'd. Opening (20 yrs.) 3,000 sq. ft.
Present Opening 1,800 sq. ft.
Proposed Opening 3,000 sq. ft.
below El. 375.0

TOTAL BILL OF MATERIAL

ITEM	SUPER	SUB	TOTAL
Name Plates	Each		1
Precast Prestressed Concrete Bridge Deck	Sq. Ft.	2684	2684
Class X Concrete	Cu. Yds	48.0	48.0
Class X Concrete Encasement	Cu. Yds	20	20
Handrail Concrete	Cu. Yds	18.7	18.7
Reinforcement Bars	Lbs	3420	3420
Steel Piles (88P36)	Lin. Ft.		1485
Test Piles (Steel 88P36)	Each	3	3
Slope Wall	Sq. Yds		446
Bituminous Materials (Prime Coat)	Gals.	78	78
Leveling Binder (Machine Method)	Tons	44	44
Bituminous Concrete Surface Course (Subcl. I)	Tons	44	44
Structural Steel	Lbs	825	825
Class A Excavation for Structures	Cu. Yds	202	202
Class B Excavation for Structures	Cu. Yds	128	128
Removal of Existing Structures	Each		1

* 30 Cu. Yds. included for Slope Wall

DESIGN STRESSES
fc = 2,000 psi (Prestress Bms.) fs = 20,000 (Perf.)
fc = 1,400 psi (Class X Conc.) fs = 173,400 (Prestress Cables)
n = 8 (Prestress Bms.); 10 (Cl. X Conc.) v = 18 psi (Ftg.)
Loading HS.15 - 44

See Sheet 7 of 16
for Borings
and General Notes

Mario J. Ricci
Illinois Structural No. 2134

GENERAL PLAN & ELEVATION
CRAB ORCHARD CREEK BRIDGE
SECTION 104B-TR CARBONDALE RD. DIST.
JACKSON COUNTY
STATION 152+54

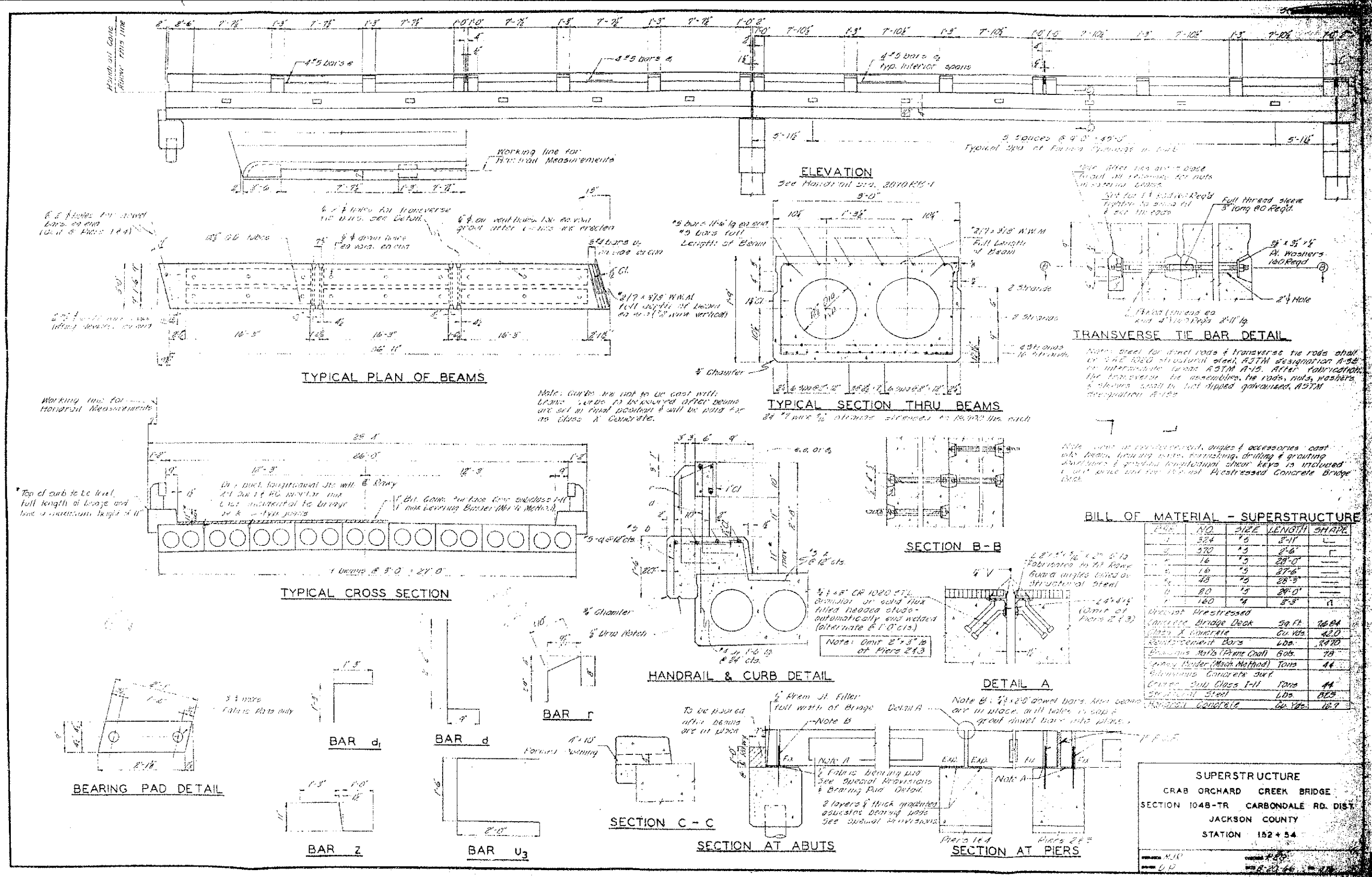

BILL OF MATERIAL - SUPERSTRUCTURE

QTY	NO.	SIZE	LENGTH	SHAPE
1	324	1/2"	2'-11"	L
3	370	1/2"	2'-6"	L
1	16	1/2"	28'-0"	L
4	16	1/2"	27'-6"	L
2	43	1/2"	28'-3"	L
0	80	1/2"	28'-0"	L
1	160	1/2"	8'-3"	L
Prestressed Concrete Bridge Deck				
			Sq. Ft.	1684
Class II Concrete				
			Cu. Yds.	420
Reinforcing Bars				
			Lbs.	3470
Prestressing Mats (Pneum. Cast)				
			Yds.	70
Formwork (Misc. Method)				
			Tons	44
Continuous Concrete Surf				
			Tons	44
Concrete 200 Class I-II				
			Tons	44
Structural Steel				
			Lbs.	555
Handrail Concrete				
			Cu. Yds.	18.7

SUPERSTRUCTURE
CRAB ORCHARD CREEK BRIDGE
SECTION 104B-TR CARBONDALE RD. DIST.
JACKSON COUNTY
STATION 152 + 54

FILE NAME: 120127-ah-crabrdgudgn
 USER NAME: *
 DESIGNED - D.W.T.
 CHECKED - S.W.M.
 DRAWN - D.A.B.
 CHECKED - S.W.M.
 PLOT SCALE: *
 PLOT DATE: 4/19/2013

DESIGNED - D.W.T.
 CHECKED - S.W.M.
 DRAWN - D.A.B.
 CHECKED - S.W.M.
 REVISED -
 REVISED -
 REVISED -
 REVISED -

STATE OF ILLINOIS
DEPARTMENT OF TRANSPORTATION

EXISTING STRUCTURE PLANS
STRUCTURE NO. 039-3097

SHEET NO. 17 OF 21 SHEETS

C.D.I. SECTION COUNTY TOTAL SHEETS SHEET NO.
 11 06-00145-00-BR JACKSON 54 50
 DILLINGER ROAD CONTRACT NO. 99509
 ILLINOIS FED. AID PROJECT



HAMPTON, LENZINI AND RENWICK, INC.
 300 STEVENSON DRIVE, SUITE 501
 SPRINGFIELD, ILLINOIS 62703
 ILLINOIS PROFESSIONAL DESIGN FIRM
 LICENSE NO. 021-000000000-0000

Sheet 17 of 21

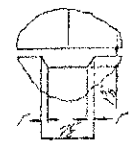

DETAIL A

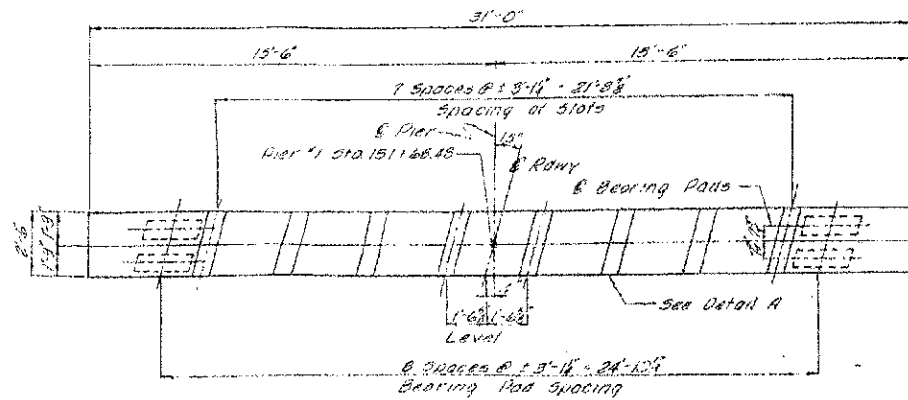

TOP PLAN

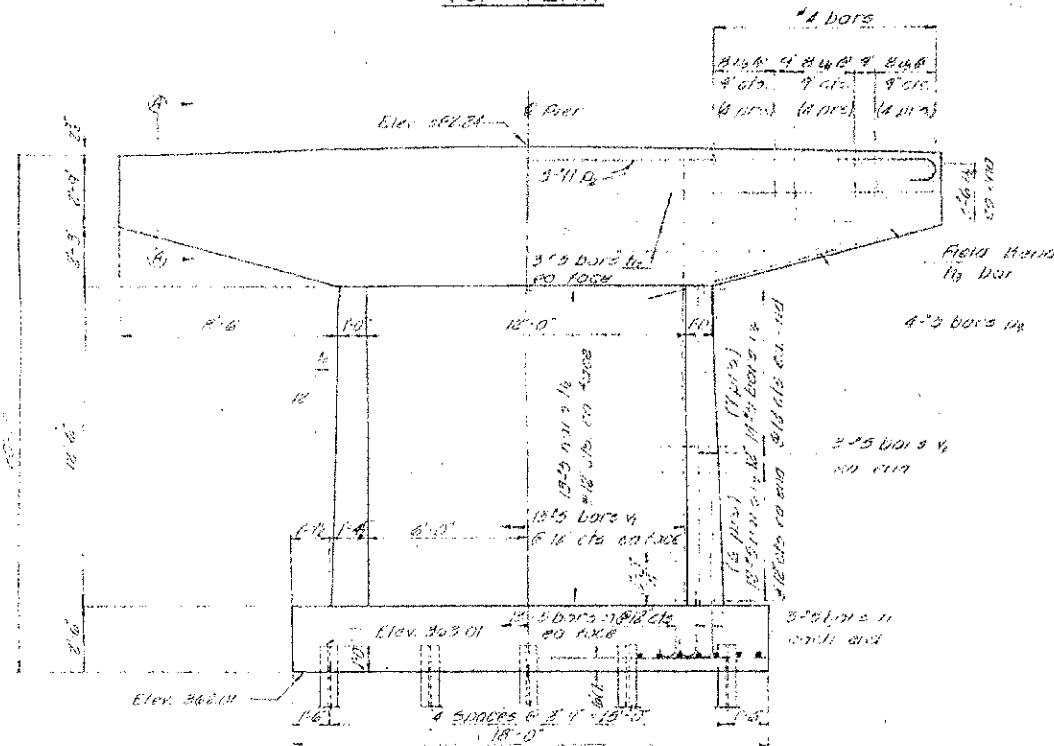

ELEVATION

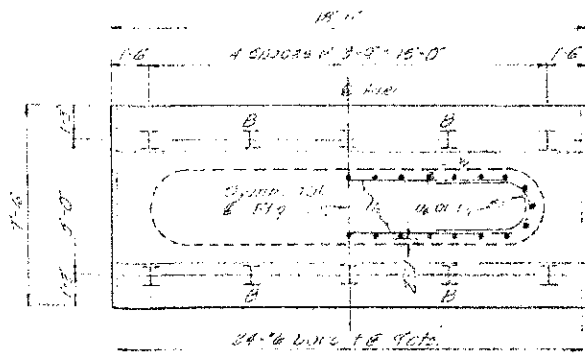

FOOTING PLAN

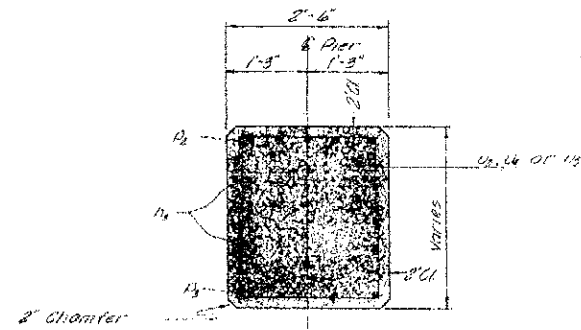

SECTION A - A

BAR	A	B
U2	2'-4"	2'-6"
U3	2'-2"	2'-10"
U4	2'-2"	2'-6"
U5	2'-2"	2'-3"

BARS U₂, U₃, U₄ & U₅

BILL OF MATERIAL - PIER I

NO.	NO.	SIZE	LENGTH	SHAPE
1	26	1/2"	12'-0"	
2	27	1/2"	30'-8"	
3	28	1/2"	8'-7"	
4	29	1/2"	24'-3"	
5	30	1/2"	10'-0"	
6	31	1/2"	17'-8"	
7	32	1/2"	17'-8"	
8	33	1/2"	17'-8"	
9	34	1/2"	17'-8"	
10	35	1/2"	17'-8"	
11	36	1/2"	17'-8"	
12	37	1/2"	17'-8"	
13	38	1/2"	17'-8"	
14	39	1/2"	17'-8"	
15	40	1/2"	17'-8"	
16	41	1/2"	17'-8"	
17	42	1/2"	17'-8"	
18	43	1/2"	17'-8"	
19	44	1/2"	17'-8"	
20	45	1/2"	17'-8"	
21	46	1/2"	17'-8"	
22	47	1/2"	17'-8"	
23	48	1/2"	17'-8"	
24	49	1/2"	17'-8"	
25	50	1/2"	17'-8"	
26	51	1/2"	17'-8"	
27	52	1/2"	17'-8"	
28	53	1/2"	17'-8"	
29	54	1/2"	17'-8"	
30	55	1/2"	17'-8"	
31	56	1/2"	17'-8"	
32	57	1/2"	17'-8"	
33	58	1/2"	17'-8"	
34	59	1/2"	17'-8"	
35	60	1/2"	17'-8"	
36	61	1/2"	17'-8"	
37	62	1/2"	17'-8"	
38	63	1/2"	17'-8"	
39	64	1/2"	17'-8"	
40	65	1/2"	17'-8"	
41	66	1/2"	17'-8"	
42	67	1/2"	17'-8"	
43	68	1/2"	17'-8"	
44	69	1/2"	17'-8"	
45	70	1/2"	17'-8"	
46	71	1/2"	17'-8"	
47	72	1/2"	17'-8"	
48	73	1/2"	17'-8"	
49	74	1/2"	17'-8"	
50	75	1/2"	17'-8"	
51	76	1/2"	17'-8"	
52	77	1/2"	17'-8"	
53	78	1/2"	17'-8"	
54	79	1/2"	17'-8"	
55	80	1/2"	17'-8"	
56	81	1/2"	17'-8"	
57	82	1/2"	17'-8"	
58	83	1/2"	17'-8"	
59	84	1/2"	17'-8"	
60	85	1/2"	17'-8"	
61	86	1/2"	17'-8"	
62	87	1/2"	17'-8"	
63	88	1/2"	17'-8"	
64	89	1/2"	17'-8"	
65	90	1/2"	17'-8"	
66	91	1/2"	17'-8"	
67	92	1/2"	17'-8"	
68	93	1/2"	17'-8"	
69	94	1/2"	17'-8"	
70	95	1/2"	17'-8"	
71	96	1/2"	17'-8"	
72	97	1/2"	17'-8"	
73	98	1/2"	17'-8"	
74	99	1/2"	17'-8"	
75	100	1/2"	17'-8"	

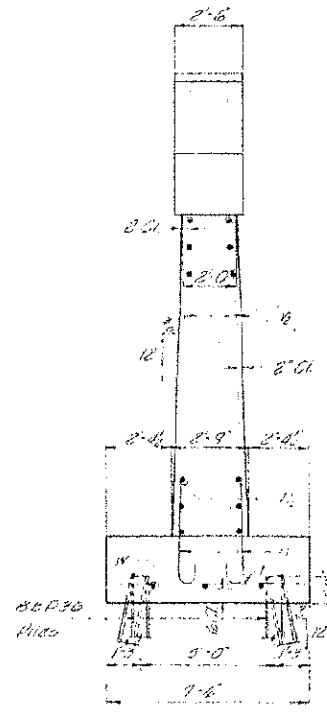

END VIEW

BAR D

BAR P₂

BARS U₂ & U₃

PILE DATA

TYPE: Steel (BBR34)
 NO. Required: 13
 Est. Length: 35 ft
 Note: Shall be driven to refusal

BAR	P	C
U2	17	2-1
U3	15	2-1

PIER I
 CRAB ORCHARD CREEK BRIDGE
 SECTION 104B-TR CARBONDALE RD. DIST.
 JACKSON COUNTY
 STATION 152 + 54

DESIGNED BY: MJK
 CHECKED BY: JLB
 DATE: 8-20-66

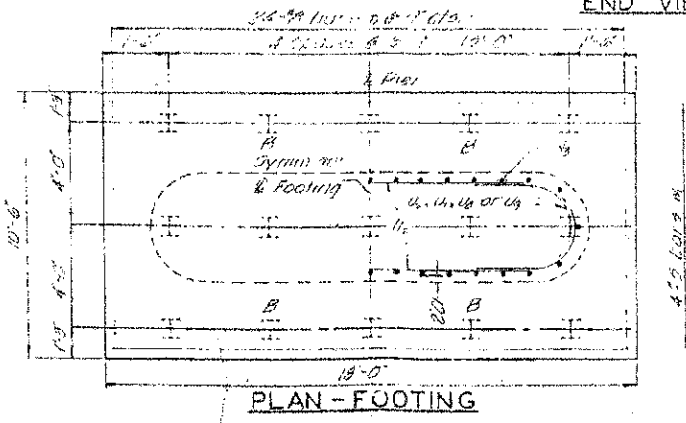
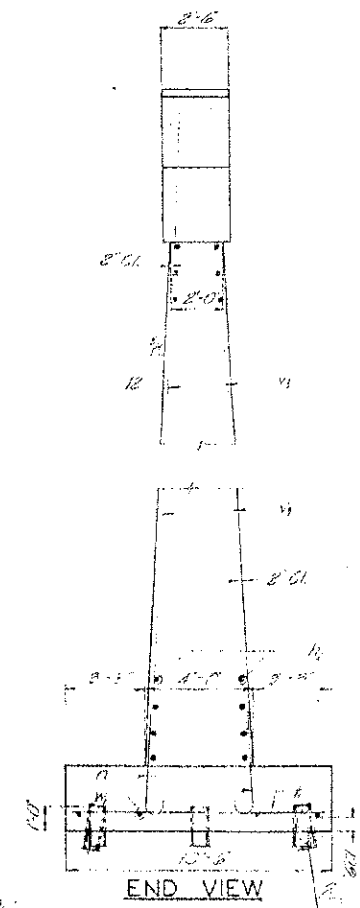
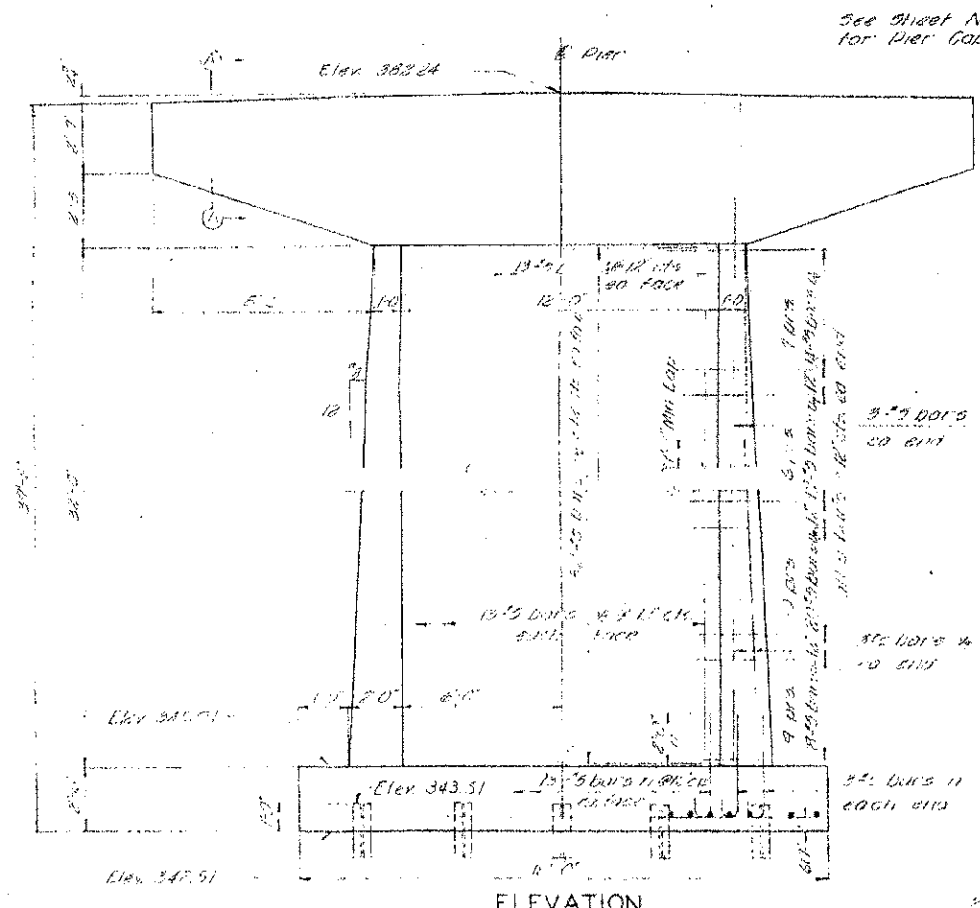
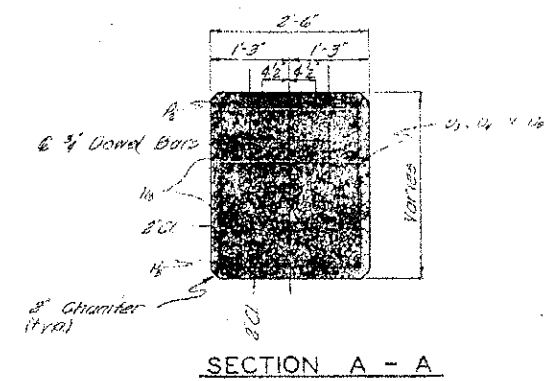
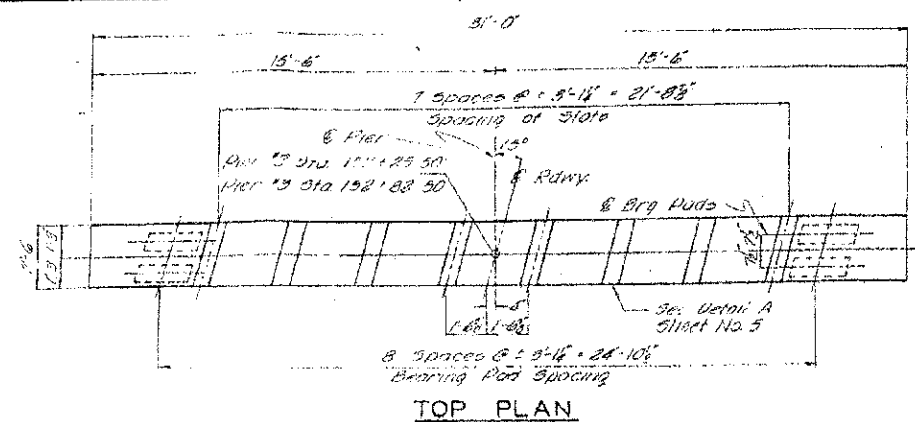

BILL OF MATERIAL - 2 PIERS

BAR NO.	SIZE	LENGTH	SHAPE
1	#4	12'-0"	U
2	#4	30'-8"	U
3	#4	7'-7"	U
4	#4	34'-2"	U
5	#4	10'-8"	U
6	#4	10'-8"	U
7	#4	7'-7"	U
8	#4	7'-7"	U
9	#4	7'-7"	U
10	#4	7'-7"	U
11	#4	7'-7"	U
12	#4	7'-7"	U
13	#4	7'-7"	U
14	#4	7'-7"	U
15	#4	7'-7"	U
16	#4	7'-7"	U
17	#4	7'-7"	U
18	#4	7'-7"	U
19	#4	7'-7"	U
20	#4	7'-7"	U
21	#4	7'-7"	U
22	#4	7'-7"	U
23	#4	7'-7"	U
24	#4	7'-7"	U
25	#4	7'-7"	U
26	#4	7'-7"	U
27	#4	7'-7"	U
28	#4	7'-7"	U
29	#4	7'-7"	U
30	#4	7'-7"	U
31	#4	7'-7"	U
32	#4	7'-7"	U
33	#4	7'-7"	U
34	#4	7'-7"	U
35	#4	7'-7"	U
36	#4	7'-7"	U
37	#4	7'-7"	U
38	#4	7'-7"	U
39	#4	7'-7"	U
40	#4	7'-7"	U
41	#4	7'-7"	U
42	#4	7'-7"	U
43	#4	7'-7"	U
44	#4	7'-7"	U
45	#4	7'-7"	U
46	#4	7'-7"	U
47	#4	7'-7"	U
48	#4	7'-7"	U
49	#4	7'-7"	U
50	#4	7'-7"	U
51	#4	7'-7"	U
52	#4	7'-7"	U
53	#4	7'-7"	U
54	#4	7'-7"	U
55	#4	7'-7"	U
56	#4	7'-7"	U
57	#4	7'-7"	U
58	#4	7'-7"	U
59	#4	7'-7"	U
60	#4	7'-7"	U
61	#4	7'-7"	U
62	#4	7'-7"	U
63	#4	7'-7"	U
64	#4	7'-7"	U
65	#4	7'-7"	U
66	#4	7'-7"	U
67	#4	7'-7"	U
68	#4	7'-7"	U
69	#4	7'-7"	U
70	#4	7'-7"	U
71	#4	7'-7"	U
72	#4	7'-7"	U
73	#4	7'-7"	U
74	#4	7'-7"	U
75	#4	7'-7"	U
76	#4	7'-7"	U
77	#4	7'-7"	U
78	#4	7'-7"	U
79	#4	7'-7"	U
80	#4	7'-7"	U
81	#4	7'-7"	U
82	#4	7'-7"	U
83	#4	7'-7"	U
84	#4	7'-7"	U
85	#4	7'-7"	U
86	#4	7'-7"	U
87	#4	7'-7"	U
88	#4	7'-7"	U
89	#4	7'-7"	U
90	#4	7'-7"	U
91	#4	7'-7"	U
92	#4	7'-7"	U
93	#4	7'-7"	U
94	#4	7'-7"	U
95	#4	7'-7"	U
96	#4	7'-7"	U
97	#4	7'-7"	U
98	#4	7'-7"	U
99	#4	7'-7"	U
100	#4	7'-7"	U

BAR	R	C
U8	1'-4"	3'-9"
U9	1'-8"	3'-3"

BARS U₈ & U₉

For Bar Details and Laps See Sheet No. 5

PILE DATA

Type: Steel Pipe
 No. Piles: 2
 Eol Length: 13'-0" (2' 5" above ground)
 Piles shall be driven to refusal
 *Includes one test pile to be driven in Pier 2.

PIERS 2 & 3
 CRAB ORCHARD CREEK BRIDGE
 SECTION 104B-TR CARBONDALE RD. DIST.
 JACKSON COUNTY
 STATION 152 + 54

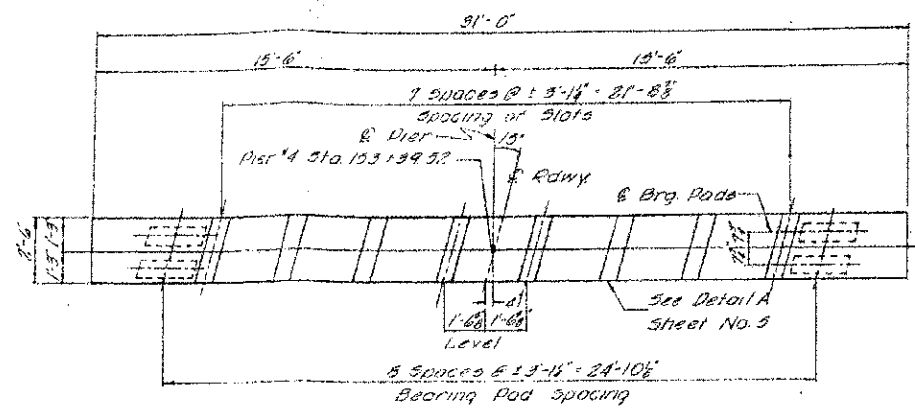

TOP PLAN

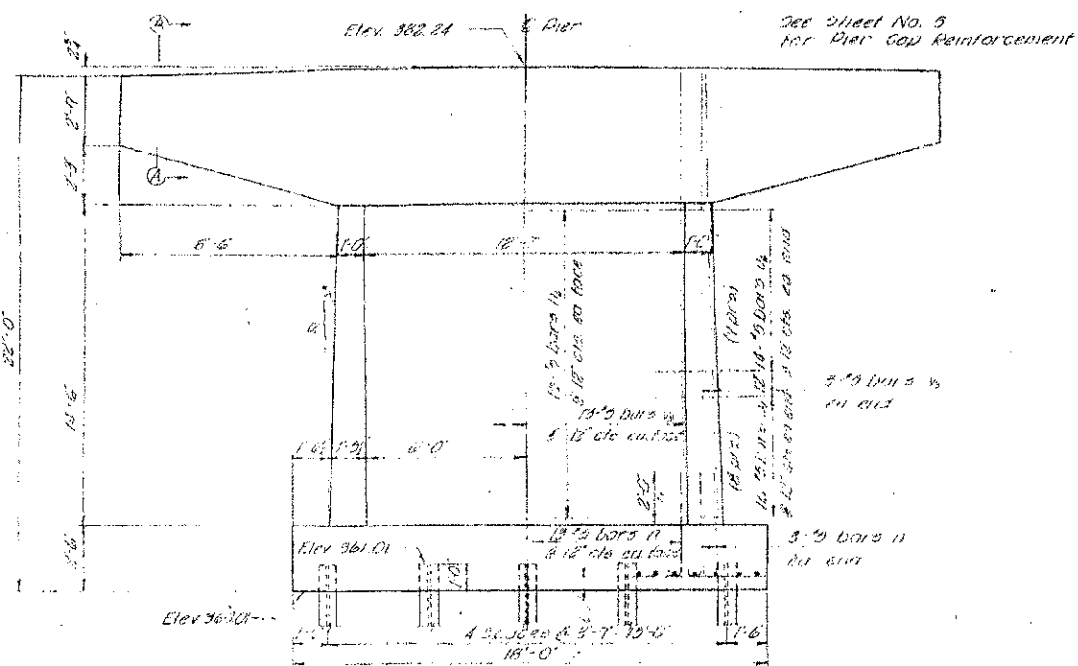

ELEVATION

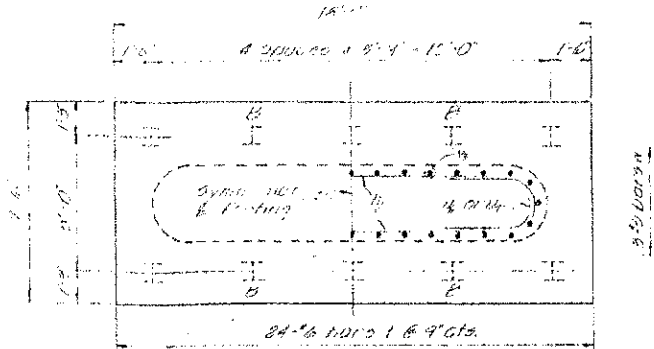

FOOTING PLAN

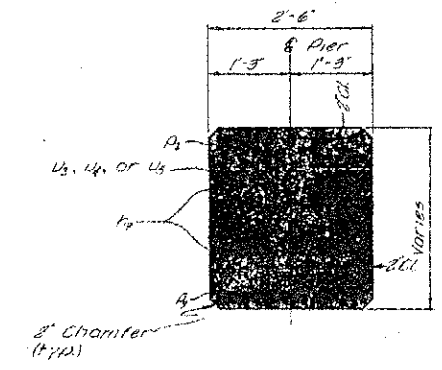

SECTION A-A

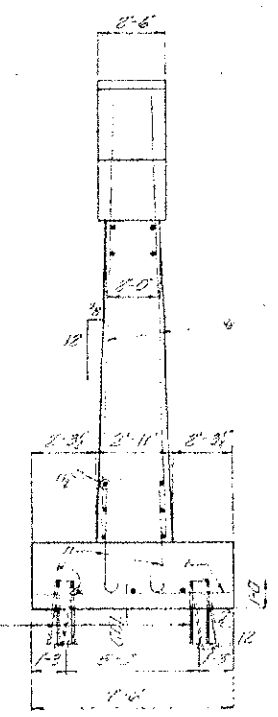

END VIEW

PILE DATA

Type: Steel (A.C.P.S.)
 No. Required: 10
 Est. Length: 12 ft.
 Piles shall be driven to refusal.
 *Includes one test pile to be driven in Pier #4.

BILL OF MATERIAL - PIER 4

BAR	NO.	SIZE	LENGTH	SHAPE	
1	20	#4	12'-0"	---	
2	4	#4	50'-8"	---	
3	21	#4	47'-0"	---	
4	3	#4	34'-3"	---	
5	4	#4	10'-0"	---	
6	24	#4	78'-0"	---	
7	6	#4	71'-0"	---	
8	16	#4	78'-0"	---	
9	16	#4	68'-0"	---	
10	28	#4	37'-0"	---	
11	32	#4	37'-0"	---	
12	32	#4	19'-3"	---	
13	8	#4	17'-0"	---	
Concrete				cu. yds	441
Reinforcement Bars				lbs	3200
Formwork (B.E.P.S.)				sq. ft.	111
Excavation (Total)				Each	1
Excavation				cu. yds	96

See End Details See Sheet # of 7
 10 16

PIER 4
 CRAB ORCHARD CREEK BRIDGE
 SECTION 104B-TR CARBONDALE RD. DIST.
 JACKSON COUNTY
 STATION 152 + 54

REVISIONS: REC, 8-20-66, 416