

F.A.P. RTE.	SECTION	COUNTY	TOTAL SHEETS	SHEET NO.
55	100 (I&2) I-9	WILL	305	162
STA.		TO STA.		
FED. ROAD DIST. NO.		ILLINOIS FED. AID PROJECT		
DETLs - 28 OF 30				

POST	CONCRETE FOUNDATION TABLE							POST TO STUB POST CONNECTION DATA										FUSE PLATE DATA				
	Foundation		Concrete (1) cu. yds.	Reinforcement			Stub Post Length	Bolt Size	A	B	C	D	E	t1	t2	R	W	J	K	L	t3	
	Diameter	Minimum Depth		Vertical Bars Length	Bar Diameter	Spirals Length																lbs. (2)
W6x9	2'-0"	6'-0"	0.70	5'-9"	1'-8 1/2"	79'-0"	78	2'-3"	5/8" x 3/4"	6"	2 1/4"	1 1/4"	3 1/2"	1 1/4"	3/4"	1/2"	1 1/2"	1 1/4"	4"	2 1/4"	7/8"	1/4"
W6x15	2'-0"	6'-0"	0.70	5'-9"	1'-8 1/2"	79'-0"	78	2'-6"	5/8" x 3/4"	6"	2 1/4"	1 1/4"	3 1/2"	1 1/4"	3/4"	1/2"	1 1/2"	1 1/4"	6"	3 1/2"	1 1/4"	3/8"
W8x18	2'-0"	6'-0"	0.70	5'-9"	1'-8 1/2"	79'-0"	78	2'-6"	3/4" x 3/4"	6"	2 1/2"	1 3/8"	3 1/4"	1 3/8"	1"	1/2"	1 1/2"	5/8"	5 1/4"	2 3/4"	1 1/4"	3/8"
W10x22	2'-6"	6'-6"	1.18	6'-3"	2'-2 1/2"	105'-0"	92	3'-0"	3/4" x 3/4"	6"	2 1/2"	1 3/8"	3 1/4"	1 3/8"	1"	1/2"	1 1/2"	5/8"	5 3/4"	2 3/4"	1 1/2"	1/2"
W10x26	2'-6"	7'-0"	1.27	6'-9"	2'-2 1/2"	112'-0"	98	3'-0"	7/8" x 4"	7"	2 3/4"	1 1/2"	4"	1 1/2"	1"	3/4"	5/32"	3/8"	5 3/4"	2 3/4"	1 1/2"	5/8"
W12x26	2'-6"	7'-9"	1.41	7'-6"	2'-2 1/2"	119'-0"	107	3'-0"	7/8" x 4"	7"	2 3/4"	1 1/2"	4"	1 1/2"	1"	3/4"	5/32"	3/8"	6 1/2"	3 1/2"	1 1/2"	5/8"
W14x30	3'-0"	7'-3"	1.90	7'-0"	2'-8 1/2"	145'-0"	113	3'-0"	7/8" x 4"	7"	2 3/4"	1 1/2"	4"	1 1/2"	1"	3/4"	5/32"	3/8"	6 3/4"	3 1/2"	1 5/8"	1/2"
W14x38	3'-0"	8'-0"	2.09	7'-9"	2'-8 1/2"	153'-0"	122	3'-6"	1" x 4 1/2"	7 1/2"	3"	1 3/4"	4"	1 3/4"	1 1/4"	3/4"	1 1/2"	3/8"	6 3/4"	3 1/2"	1 5/8"	1/2"
W16x45	3'-0"	8'-6"	2.23	8'-3"	2'-8 1/2"	162'-0"	130	3'-6"	1" x 4 1/2"	7 1/2"	3"	1 3/4"	4"	1 3/4"	1 1/4"	3/4"	1 1/2"	3/8"	7"	3 1/2"	1 3/4"	1/2"

*Dimensional changes required for varying site conditions shall be approved by the Engineer.

POST	FUSE PLATE BOLT SIZE													
	Sign Depth													
	4'-0"	5'-0"	6'-0"	7'-0"	8'-0"	9'-0"	10'-0"	11'-0"	12'-0"	13'-0"	14'-0"	15'-0"	16'-0"	
W6x9	1/2" x 1 1/2"	1/2" x 1 1/2"	1/2" x 1 1/2"	5/8" x 1 3/4"	5/8" x 1 3/4"	5/8" x 1 3/4"	---	---	---	---	---	---	---	
W6x15	1/2" x 1 3/4"	1/2" x 1 3/4"	5/8" x 2"	5/8" x 2"	3/4" x 2"	3/4" x 2"	3/4" x 2"	3/4" x 2"	7/8" x 2"	7/8" x 2"	---	---	---	
W8x18	1/2" x 1 3/4"	1/2" x 1 3/4"	5/8" x 2"	5/8" x 2"	5/8" x 2"	3/4" x 2"	3/4" x 2"	7/8" x 2 1/4"	7/8" x 2 1/4"	7/8" x 2 1/4"	7/8" x 2 1/4"	7/8" x 2 1/4"	7/8" x 2 1/4"	
W10x22	1/2" x 2"	1/2" x 2"	1/2" x 2"	5/8" x 2"	5/8" x 2"	3/4" x 2 1/4"	3/4" x 2 1/4"	7/8" x 2 1/4"	7/8" x 2 1/4"	7/8" x 2 1/4"	1" x 2 1/2"	1" x 2 3/4"	1" x 2 3/4"	
W10x26	1/2" x 2"	1/2" x 2"	1/2" x 2"	5/8" x 2 1/4"	5/8" x 2 1/4"	3/4" x 2 1/2"	3/4" x 2 1/2"	7/8" x 2 1/2"	7/8" x 2 1/2"	1" x 2 3/4"	1" x 2 3/4"	1" x 2 3/4"	1 1/8" x 3"	
W12x26	---	---	---	---	---	5/8" x 2 1/4"	---	---	7/8" x 2 1/2"	7/8" x 2 1/2"	1" x 2 1/2"	1" x 2 3/4"	1" x 2 3/4"	
W14x30	1/2" x 2"	1/2" x 2"	1/2" x 2"	1/2" x 2"	1/2" x 2"	5/8" x 2"	3/4" x 2 1/4"	3/4" x 2 1/4"	3/4" x 2 1/4"	7/8" x 2 1/2"	1" x 2 1/2"	1" x 2 3/4"	1" x 2 3/4"	
W14x38	---	1/2" x 2"	1/2" x 2"	1/2" x 2"	1/2" x 2"	5/8" x 2 1/4"	3/4" x 2 1/4"	3/4" x 2 1/2"	3/4" x 2 1/2"	7/8" x 2 1/2"	7/8" x 2 1/2"	1" x 2 1/2"	1" x 2 3/4"	
W16x45	---	---	---	1/2" x 2"	1/2" x 2"	5/8" x 2 1/4"	5/8" x 2 1/4"	3/4" x 2 1/4"	3/4" x 2 1/2"	3/4" x 2 1/2"	7/8" x 2 1/2"	7/8" x 2 1/2"	1" x 2 3/4"	

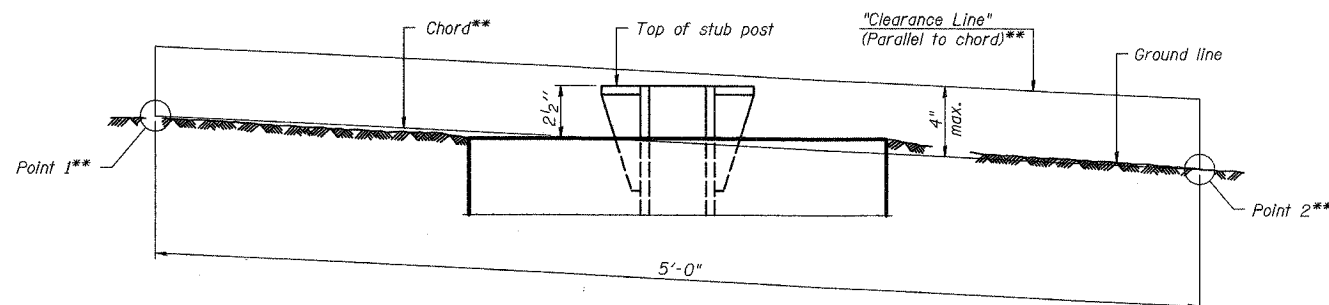

**ELEVATION
GROUND LINE & STUB POST**

** For all "Point 1" and "Point 2" locations, "Clearance Line" must be at or above top of stub post.

- ① Quantity includes all concrete necessary for one foundation.
- ② Includes reinforcement bars and spiral hooping for one foundation.

NUMBER	REVISION	DATE

DAVID MASON & ASSOCIATES
Civil Engineering
Structural Engineering
Surveying
445 E. Illinois, Suite 640
Chicago, IL 60611
(312) 945-9600

PARSONS BRINCKERHOFF

REVISIONS	
NAME	DATE

BAW-A-2 1-7-05
ILLINOIS DEPARTMENT OF TRANSPORTATION
F.A.I. I-55
143rd STREET TO WEBER RD.
BREAK-AWAY WIDE FLANGE
STEEL SIGN POST TABLES
SCALE: DRAWN BY: JS, LC
DATE: FEBRUARY 23, 2007 CHECKED BY: SE