

F.A.U. RTE.	SECTION	COUNTY	TOTAL SHEETS	SHEET NO.
3887	(E-1, P, G, H & R) RS-5	KANE	43	1

STATE OF ILLINOIS
DEPARTMENT OF TRANSPORTATION
DIVISION OF HIGHWAYS

D-91-250-07

FOR INDEX OF SHEETS, SEE SHEET NO. 2

PROPOSED HIGHWAY PLANS

IMPROVEMENT LOCATED IN THE CITY OF ELGIN & THE VILLAGE OF WEST DUNDEE

F.A.U. 3887: IL 31

SECTION: (E-1, P, G, H & R) RS-5

TOLLGATE RD. TO ELGIN STATE HOSPITAL
SOUTH ENTRANCE AND OVER TYLER CREEK
RESURFACING (3P) & BRIDGE DECK REPAIR
KANE COUNTY

C-91-250-07

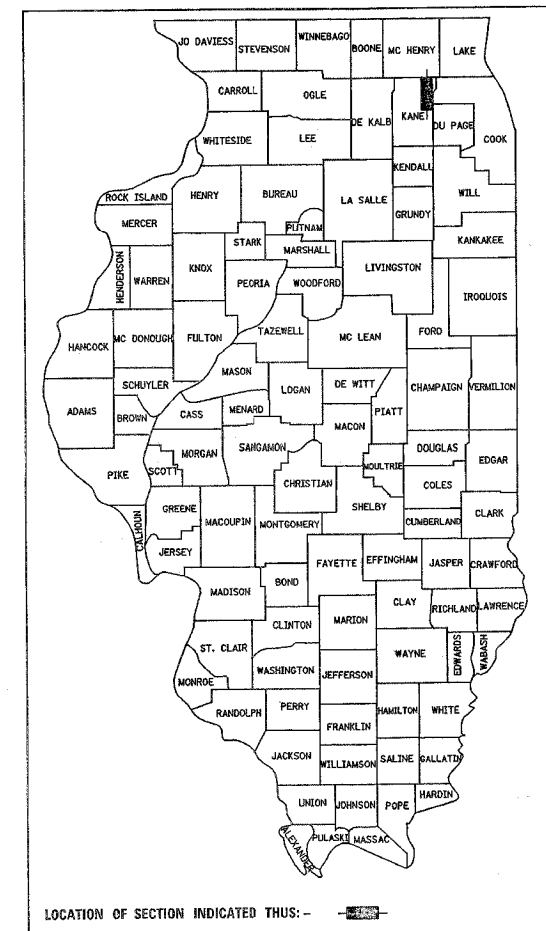

DISTRICT ONE - DESIGN: PLAN PREPARATION ENGINEER KEN ENG / LONG TRAN (847) 705-4240

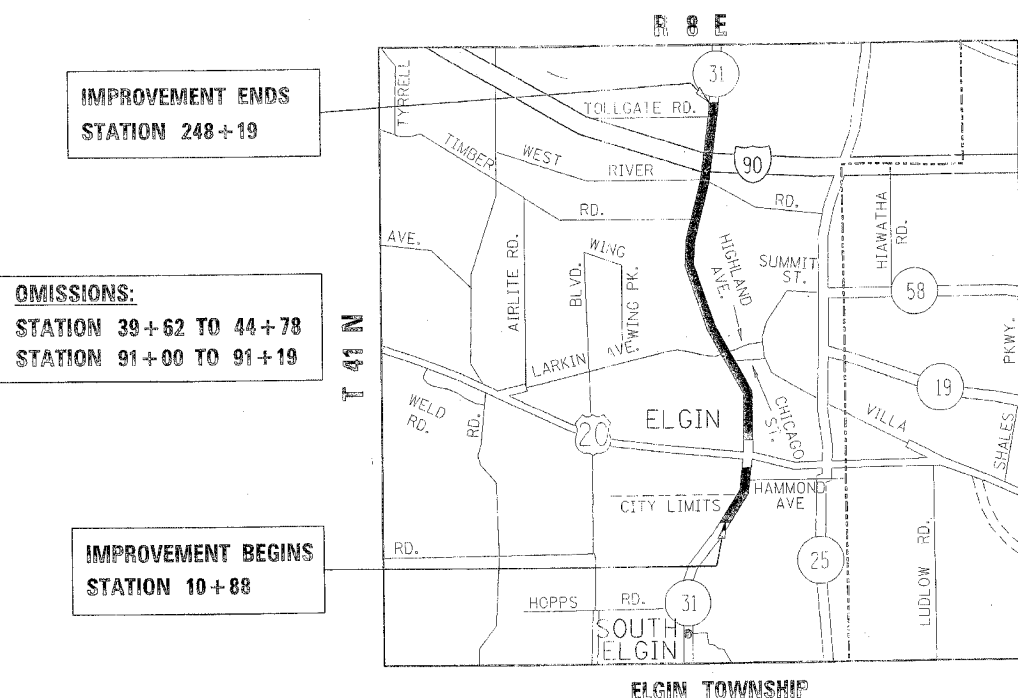

IMPROVEMENT ENDS
STATION 248+19

OMISSIONS:
STATION 39+62 TO 44+78
STATION 91+00 TO 91+19

IMPROVEMENT BEGINS
STATION 10+88

TRAFFIC DATA
2005 ADT = 32,800
POSTED SPEED = 35 MPH

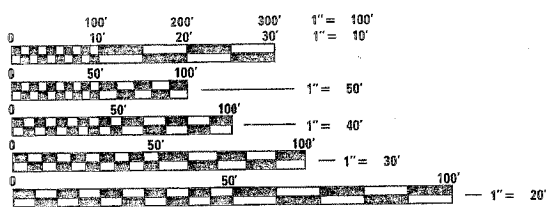

FULL SIZE PLANS HAVE BEEN PREPARED USING STANDARD ENGINEERING SCALES, REDUCED SIZED PLANS WILL NOT CONFORM TO STANDARD SCALES, IN MAKING MEASUREMENTS ON REDUCED PLANS, THE ABOVE SCALES MAY BE USED.

CONTRACT NO. 60C64

GROSS & NET LENGTH OF IMPROVEMENT = 23,731 FEET = 4.49 MILES
NET LENGTH OF IMPROVEMENT = 23,196 FEET = 4.39 MILES

STATE OF ILLINOIS
DEPARTMENT OF TRANSPORTATION
DIVISION OF HIGHWAYS

SUBMITTED April 18 2007
Diane O'Keefe
DEPUTY DIRECTOR OF HIGHWAYS, REGION ENGINEER

May 11 2007
Eric E. Harman
ENGINEER OF DESIGN AND ENVIRONMENT

May 11 2007
Milton R. See P.E.
DIRECTOR OF HIGHWAYS, CHIEF ENGINEER

PRINTED BY THE AUTHORITY OF THE STATE OF ILLINOIS

FOR UTILITY INFORMATION
CALL J.U.L.I.E. 1-800-892-0123
"JOINT UTILITY LOCATION INFORMATION FOR EXCAVATION"

F.A.U. RTE.	SECTION	COUNTY	TOTAL SHEETS	SHEET NO.
3887	(E-1, P, G, H & R) RS-5	KANE	43	2
STA. +		TO STA. +		
FED. ROAD DIST. NO. 1		ILLINOIS		HIGHWAY PROJECT

INDEX OF SHEETS

- 1 COVER SHEET
- 2 INDEX OF SHEETS, STATE STANDARDS, AND GENERAL NOTES
- 3-4 SUMMARY OF QUANTITIES
- 5-9 EXISTING & PROPOSED TYPICAL SECTIONS
- 10-18 ROADWAY & PAVEMENT MARKING PLANS
- 19-21 BRIDGE REPAIR PLANS
- 22-32 DETECTOR LOOP REPLACEMENT PLANS
- 33 DETAILS FOR FRAMES & LIDS ADJUSTMENT WITH MILLING
- 34 PAVEMENT PATCHING FOR HMA SURFACED PAVEMENT
- 35 CURB OR CURB AND GUTTER REMOVAL & REPLACEMENT
- 36 BUTT JOINT AND HMA TAPER DETAILS
- 37 TRAFFIC CONTROL AND PROTECTION FOR SIDE ROADS, INTERSECTION, AND DRIVEWAYS
- 38 TRAFFIC CONTROL AND PROTECTION AT TURN BAYS (TO REMAIN OPEN TO TRAFFIC)
- 39 DISTRICT 1 DETECTOR LOOP INSTALLATION DETAILS FOR ROADWAY RESURFACING
- 40 DISTRICT ONE TYPICAL PAVEMENT MARKINGS
- 41 TYPICAL APPLICATIONS RAISED REFLECTIVE PAVEMENT MARKERS (SNOW-PLOW RESISTANT)
- 42 ARTERIAL ROAD INFORMATION SIGN
- 43 PAVEMENT MARKING LETTERS AND SYMBOLS FOR TRAFFIC STAGING

GENERAL NOTES

BEFORE STARTING ANY EXCAVATION, THE CONTRACTOR SHALL CALL "JULIE" AT 1-800-892-0123 FOR FIELD LOCATIONS OF BURIED ELECTRIC, TELEPHONE AND GAS FACILITIES. (48 HOUR NOTIFICATION IS REQUIRED).

THE MAXIMUM GRADE DIFFERENTIAL BETWEEN LANES SHALL NOT EXCEED 40MM (1-1/2 INCHES) WHERE THE SPEED LIMIT IS 80 KM/H (45 MPH) OR LESS AND 25MM (1 INCH) WHERE THE SPEED LIMIT IS GREATER THAN 80 KM/H (45 MPH).

THE CONTRACTOR SHALL COORDINATE CONSTRUCTION ACTIVITIES WITH UTILITY COMPANIES, THE CITY OF ELGIN, AND THE VILLAGE OF WEST DUNDEE.

THE CONTRACTOR WILL NOT BE ABLE TO SET UP A YARD OR FIELD OFFICE ON STATE PROPERTY WITHOUT WRITTEN PERMISSION FROM THE DEPARTMENT.

THE RESIDENT ENGINEER SHOULD CONTACT MR. DON CHIARUGI, AREA TRAFFIC FIELD ENGINEERS, AT (847) 741-9857 OR (847) 715-8416 (CELL) PRIOR TO INSTALLING ANY PAVEMENT MARKING.

THE CONTRACTOR SHALL CONTACT THE DISTRICT ONE ARTERIAL TRAFFIC CONTROL SUPERVISOR AT (847) 705-4470 A MINIMUM OF 72 HOURS IN ADVANCE OF BEGINNING WORK.

THE RESIDENT ENGINEER SHALL VERIFY ALL EXISTING PAVEMENT MARKINGS PRIOR TO MILLING AND/OR RESURFACING OPERATION.

THE RESIDENT ENGINEER SHALL MAKE ANY NECESSARY CHANGES TO DETECTOR LOOP QUANTITIES ACCORDINGLY, IF THERE ARE ANY CHANGES IN RESURFACING LIMITS.

LIMITS OF RESURFACING ON SIDE-STREETS THROUGH OUT THE IMPROVEMENT SHALL BE TO THE RADIUS OF RETURN, AS SHOWN ON THE PLANS, AND/OR AS DIRECTED BY THE ENGINEER.

ALL FINAL PAVEMENT MARKINGS SHALL BE THERMOPLASTIC (OF THE EXTRUDED TYPE) AND SHOULD BE PLACED IN ACCORDANCE WITH "DISTRICT ONE TYPICAL PAVEMENT MARKINGS" DETAIL, (TC-13).

ALL RAISED REFLECTIVE PAVEMENT MARKERS SHALL BE PLACED IN ACCORDANCE WITH THE DISTRICT ONE "TYPICAL APPLICATIONS RAISED REFLECTIVE MARKER DETAIL," (TC-11).

STATE STANDARDS

- 000001-04 STANDARD SYMBOLS, ABBREVIATIONS AND PATTERNS
- 442201-02 CLASS C AND D PATCHES
- 604001-02 FRAME AND LIDS, TYPE 1
- 604086-01 FRAME AND GRATE, TYPE 23
- 701411-03 LANE CLOSURE, MULTILANE, AT ENTRANCE OR EXIT RAMP, FOR SPEEDS \geq 45 MPH
- 701501-03 URBAN LANE CLOSURE, 2L, 2W, UNDIVIDED
- 701601-04 URBAN LANE CLOSURE, MULTILANE, 1W OR 2W WITH NONTRAVERSABLE MEDIAN
- 701606-04 URBAN LANE CLOSURE, MULTILANE, 2W WITH MOUNTABLE MEDIAN
- 701701-04 URBAN LANE CLOSURE, MULTILANE INTERSECTION
- 701801-03 URBAN LANE CLOSURE, MULTILANE 1W OR 2W CROSSWALK OR SIDEWALK CLOSURE
- 702001-06 TRAFFIC CONTROL DEVICES

REVISIONS	
NAME	DATE

ILLINOIS DEPARTMENT OF TRANSPORTATION
 INDEX OF SHEETS, GENERAL NOTES,
 AND STATE STANDARDS

SCALE: VERT. DRAWN BY
 HORIZ. CHECKED BY
 DATE 4/18/2007

F.A. RTE.	SECTION	COUNTY	TOTAL SHEETS	SHEET NO.
3887	4E-1, P, G, H & R) RS-5	KANE	43	3
FED. ROAD DIST. NO. 1		ILLINOIS	HIGHWAY PROJECT	

SUMMARY OF QUANTITIES			CONSTRUCTION TYPE CODE					
CODE NO	ITEM	UNIT	TOTAL QUANTITIES 100% STATE	URBAN I000 ROADWAY	URBAN SFTY-2A SN: 045-0015			
20201006	GRADING AND SHAPING SHOULDERS	UNIT	44	44				
40600200	BITUMINOUS MATERIALS (PRIME COAT)	TON	45	45				
40600300	AGGREGATE (PRIME COAT)	TON	215	215				
40600400	MIXTURE FOR CRACKS, JOINTS, AND FLANGEWAYS	TON	65	65				
40600895	CONSTRUCTING TEST STRIP	EACH	3	3				
40600982	HOT-MIX ASPHALT SURFACE REMOVAL - BUTT JOINT	SQ YD	950	950				
40601005	HOT-MIX ASPHALT REPLACEMENT OVER PATCHES	TON	4855	4855				
40603595	POLYMERIZED HOT-MIX ASPHALT SURFACE COURSE, MIX "F", N90	TON	10555	10555				
42001300	PROTECTIVE COAT	SQ YD	3407	3120	287			
44000156	HOT-MIX ASPHALT SURFACE REMOVAL, 1 3/4"	SQ YD	270	270				
44000159	HOT-MIX ASPHALT SURFACE REMOVAL, 2 1/2"	SQ YD	104545	104545				
44000915	HOT-MIX ASPHALT SURFACE REMOVAL (DECK)	SQ YD	287		287			
44001700	COMBINATION CONCRETE CURB AND GUTTER REMOVAL AND REPLACEMENT	FOOT	14020	14020				
44002220	HOT-MIX ASPHALT REMOVAL OVER PATCHES, 5"	SQ YD	16825	16825				
44201765	CLASS D PATCHES, TYPE II, 10 INCH	SQ YD	12098	12098				
44201769	CLASS D PATCHES, TYPE III, 10 INCH	SQ YD	486	486				
44201771	CLASS D PATCHES, TYPE IV, 10 INCH	SQ YD	4241	4241				
48102100	AGGREGATE WEDGE SHOULDER, TYPE B	TON	176	176				
50300260	BRIDGE DECK GROOVING	SQ YD	270		270			
55039700	STORM SEWERS TO BE CLEANED	FOOT	1200	1200				
60255800	MANHOLES TO BE ADJUSTED WITH NEW TYPE 1 FRAME, CLOSED LID	EACH	5	5				
60261530	INLETS TO BE ADJUSTED WITH NEW TYPE 23 FRAME AND GRATE	EACH	5	5				
60300305	FRAMES AND LIDS TO BE ADJUSTED	EACH	10	10				
60300310	FRAMES AND LIDS TO BE ADJUSTED (SPECIAL)	EACH	180	180				
67000400	ENGINEER'S FIELD OFFICE, TYPE A	CAL MO	6	5	1			

SUMMARY OF QUANTITIES			CONSTRUCTION TYPE CODE					
CODE NO	ITEM	UNIT	TOTAL QUANTITIES 100% STATE	URBAN I000 ROADWAY	URBAN SFTY-2A SN: 045-0015			
67100100	MOBILIZATION	L SUM	1	0.9	0.1			
70102620	TRAFFIC CONTROL AND PROTECTION, STANDARD 701501	L SUM	1	1				
70102625	TRAFFIC CONTROL AND PROTECTION, STANDARD 701606	L SUM	1	0.8	0.2			
70102630	TRAFFIC CONTROL AND PROTECTION, STANDARD 701601	L SUM	1	1				
70102635	TRAFFIC CONTROL AND PROTECTION, STANDARD 701701	L SUM	1	1				
70102640	TRAFFIC CONTROL AND PROTECTION, STANDARD 701801	L SUM	1		1			
70102670	TRAFFIC CONTROL AND PROTECTION, STANDARD 701601, SPECIAL	L SUM	1		1			
70300100	SHORT-TERM PAVEMENT MARKING	FOOT	17375	17375				
70300210	TEMPORARY PAVEMENT MARKING - LETTERS AND SYMBOLS	SQ FT	1840	1840				
70300220	TEMPORARY PAVEMENT MARKING - LINE 4"	FOOT	43585	43585				
70300240	TEMPORARY PAVEMENT MARKING - LINE 6"	FOOT	7810	7810				
70300250	TEMPORARY PAVEMENT MARKING - LINE 8"	FOOT	4310	4310				
70300260	TEMPORARY PAVEMENT MARKING - LINE 12"	FOOT	2150	2150				
70300280	TEMPORARY PAVEMENT MARKING - LINE 24"	FOOT	1156	1156				
70301000	WORK ZONE PAVEMENT MARKING REMOVAL	SQ FT	16100	16100				
* 78000100	THERMOPLASTIC PAVEMENT MARKING - LETTERS AND SYMBOLS	SQ FT	1840	1840				
* 78000200	THERMOPLASTIC PAVEMENT MARKING - LINE 4"	FOOT	43585	43585				
* 78000400	THERMOPLASTIC PAVEMENT MARKING - LINE 6"	FOOT	7810	7810				
* 78000500	THERMOPLASTIC PAVEMENT MARKING - LINE 8"	FOOT	4310	4310				
* 78000600	THERMOPLASTIC PAVEMENT MARKING - LINE 12"	FOOT	2150	2150				
* 78000650	THERMOPLASTIC PAVEMENT MARKING - LINE 24"	FOOT	1156	1156				

* SPECIALTY ITEM
~~# NON PARTICIPATING ITEM~~

* SPECIALTY ITEM
~~# NON PARTICIPATING ITEM~~

REVISIONS	
NAME	DATE

ILLINOIS DEPARTMENT OF TRANSPORTATION
 SUMMARY OF QUANTITIES
 IL 31: ELGIN STATE HOSPITAL SOUTH
 ENTRANCE TO TOLLGATE ROAD AND
 OVER TYLER CREEK

4/18/2007 2:48:01 PM C:\p\collec\elstaf\5011\plan_04v.dwg

F.A.U. RTE.	SECTION	COUNTY	TOTAL SHEETS	SHEET NO.
3887	(E-1, P, G, H & R) RS-5	KANE	43	4
FED. ROAD DIST. NO. 1	ILLINOIS	HIGHWAY PROJECT		

SUMMARY OF QUANTITIES			TOTAL QUANTITIES 100% STATE	CONSTRUCTION TYPE CODE				
CODE NO	ITEM	UNIT		URBAN 1000 ROADWAY	URBAN SFTY-2A SN: 045-0015			
* 78008210	POLYUREA PAVEMENT MARKING TYPE I - LINE 4"	FOOT	178		178			
* 78008230	POLYUREA PAVEMENT MARKING TYPE I - LINE 6"	FOOT	37		37			
* 78100100	RAISED REFLECTIVE PAVEMENT MARKER	EACH	1605	1605				
* 78100105	RAISED REFLECTIVE PAVEMENT MARKER (BRIDGE)	EACH	5		5			
78300200	RAISED REFLECTIVE PAVEMENT MARKER REMOVAL	EACH	1410	1405	5			
* 88600600	DETECTOR LOOP REPLACEMENT	FOOT	3079	3079				
X0325768	SILICONE JOINT SEALER 1/2"	FOOT	37		37			
X0322256	TEMPORARY INFORMATION SIGNING	SQ FT	51.4	51.4				
X0322489	BRIDGE DECK LATEX CONCRETE OVERLAY, 2 1/2 INCHES	SQ YD	287		287			
X4067107	POLYMERIZED LEVELING BINDER (MACHINE METHOD), IL-4.75, N50	TON	4525	4525				
X7011420	TRAFFIC CONTROL AND PROTECTION, STANDARD 701411	L SUM	1	0.5	0.5			
XX002267	MEDIAN REMOVAL AND REPLACEMENT	SQ FT	450	450				
Z0006204	BRIDGE DECK HYDRO-SCARIFICATION 1/2"	SQ YD	287		287			
Z0018500	DRAINAGE STRUCTURES TO BE CLEANED	EACH	50	50				
Z0048665	RAILROAD PROTECTIVE LIABILITY INSURANCE	L SUM	1	1				

SUMMARY OF QUANTITIES			TOTAL QUANTITIES	CONSTRUCTION TYPE CODE			
CODE NO	ITEM	UNIT					

* SPECIALTY ITEM
~~# NON-PARTICIPATING ITEM~~

REVISIONS	
NAME	DATE

ILLINOIS DEPARTMENT OF TRANSPORTATION
 SUMMARY OF QUANTITIES
 IL 31: ELGIN STATE HOSPITAL SOUTH
 ENTRANCE TO TOLLGATE ROAD AND
 OVER TYLER CREEK

Rev.

4/18/2007

F.A.U. RTE.	SECTION	COUNTY	TOTAL SHEETS	SHEET NO.
3887	E-1, F, G, H & RI RS-5	KANE	43	5
STA. +	TO STA. +			
FED. ROAD DIST. NO. 1	ILLINOIS	HIGHWAY PROJECT		

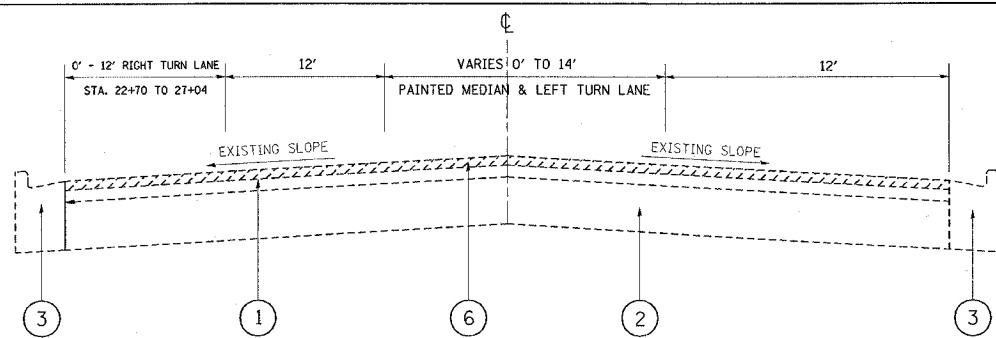

EXISTING TYPICAL CROSS SECTION
STA. 10+88 TO STA. 32+00

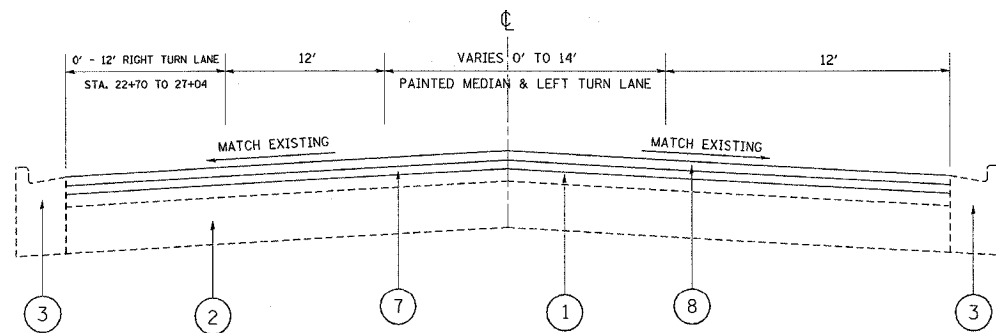

PROPOSED TYPICAL CROSS SECTION
STA. 10+88 TO STA. 32+00

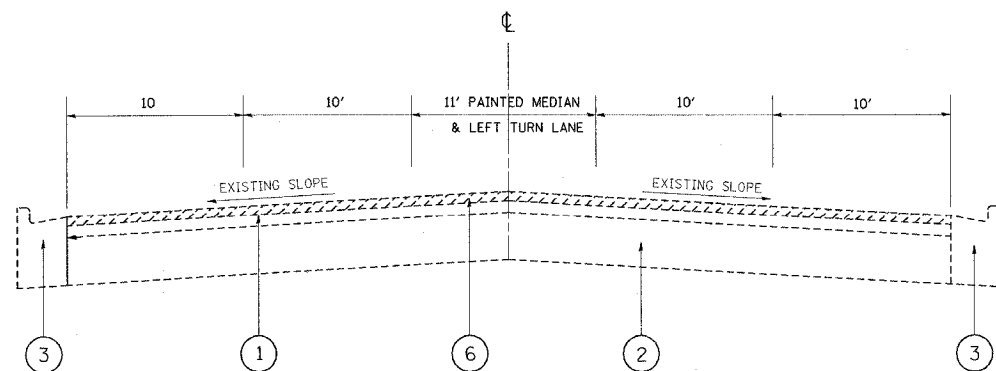

EXISTING TYPICAL CROSS SECTION
STA. 32+00 TO STA. 39+62

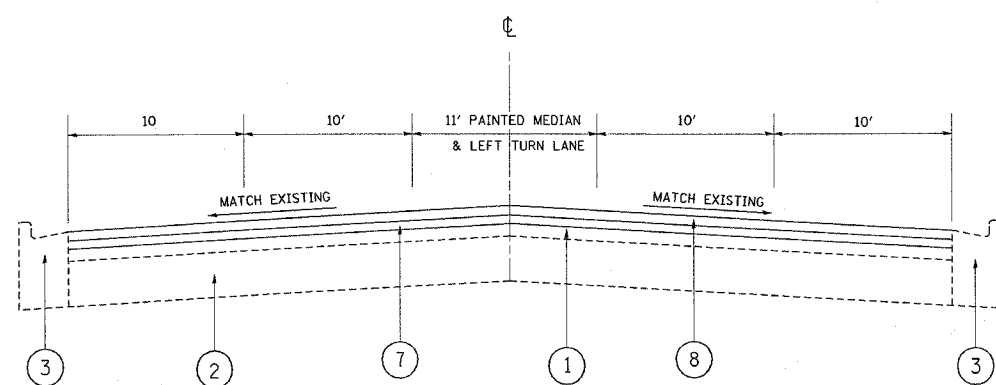

PROPOSED TYPICAL CROSS SECTION
STA. 32+00 TO STA. 39+62

LEGEND

- ① EXISTING HOT-MIX ASPHALT OVERLAY, 5" (±)
- ② EXISTING P.C.C. BASE COURSE, 10" (±)
- ③ EXISTING COMBINATION CONCRETE CURB & GUTTER
- ④ EXISTING RAISED MEDIAN
- ⑤ PROPOSED HOT-MIX ASPHALT SURFACE REMOVAL, 1 3/4" (PARKING LANES AND BRIDGE APPROACH SLAB)
- ⑥ PROPOSED HOT-MIX ASPHALT SURFACE REMOVAL, 2 1/2"
- ⑦ PROPOSED POLYMERIZED LEVELING BINDER (MM), IL-4.75, N50, (3/4")
- ⑧ PROPOSED POLYMERIZED HMA SURFACE COURSE, MIX "F", N90, (1 3/4")

▨ DENOTES REMOVAL

HMA MIXTURE REQUIREMENTS

MIXTURE USE	AC TYPE	AIR VOIDS (%)
PAVEMENT PATCHING		
HMA REPLACEMENT OVER PATCHES (HMA BINDER IL-19.0 mm)	PG 64-22/58-22*	4 % @ 70 GYR.
CLASS D PATCHES (HMA BINDER IL-19.0 mm)	PG 64-22/58-22*	4 % @ 70 GYR.
PAVEMENT RESURFACING		
POLYMERIZED HMA SURFACE COURSE, MIX "F", N90, (IL-9.5 mm)	5B5/5BR PG 70-22	4 % @ 90 GYR.
POLYMERIZED HMA LEVELING BINDER (MM), IL-4.75, N50, 3/4"	5B5/5BR PG 76-28/22	4 % @ 70 GYR.

THE UNIT WEIGHT USED TO CALCULATE ALL HOT-MIX ASPHALT SURFACE MIXTURES IS 112 IBS/SY.IN
 * WHEN RAP EXCEEDS 20% THE NEW ASPHALT BINDER IN THE MIX SHALL BE PG 58-22

REVISIONS	
NAME	DATE

ILLINOIS DEPARTMENT OF TRANSPORTATION
IL 31
 EXISTING AND PROPOSED
 TYPICAL SECTIONS

SCALE: VERT. NONE
 HORIZ. DATE 4/18/2007
 DRAWN BY
 CHECKED BY

Rev.

F.A.U. RTE.	SECTION	COUNTY	TOTAL SHEETS	SHEET NO.
3887	(E-1, P, G, H & R) RS-5	KANE	43	6
STA. +	TO STA. +			
FED. ROAD DIST. NO. 1	ILLINOIS	HIGHWAY PROJECT		

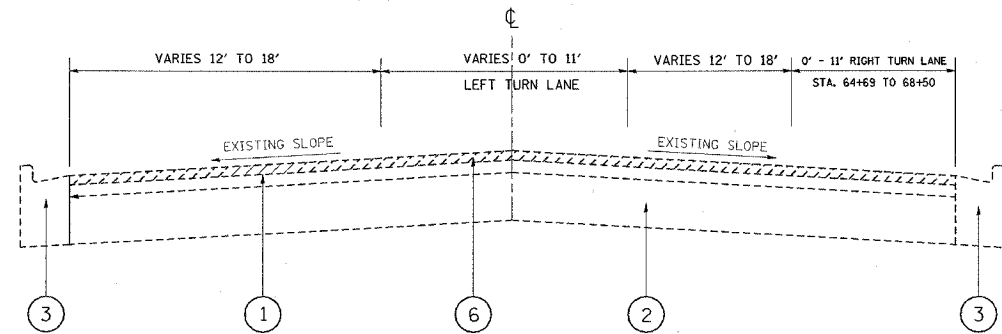

EXISTING TYPICAL CROSS SECTION
STA. 44+78 TO STA. 96+88

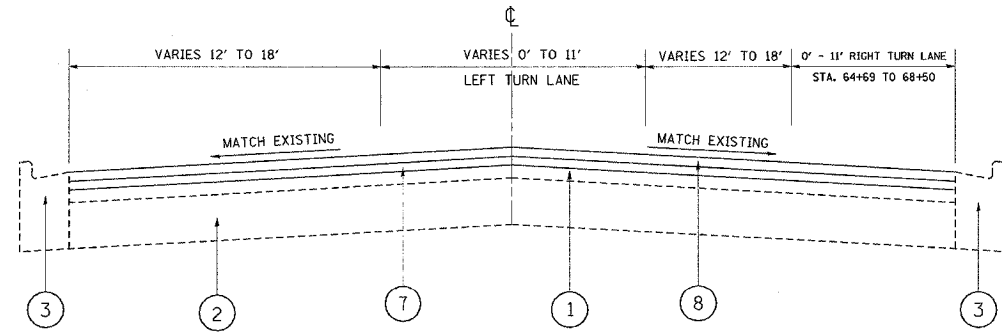

PROPOSED TYPICAL CROSS SECTION
STA. 44+78 TO STA. 96+88

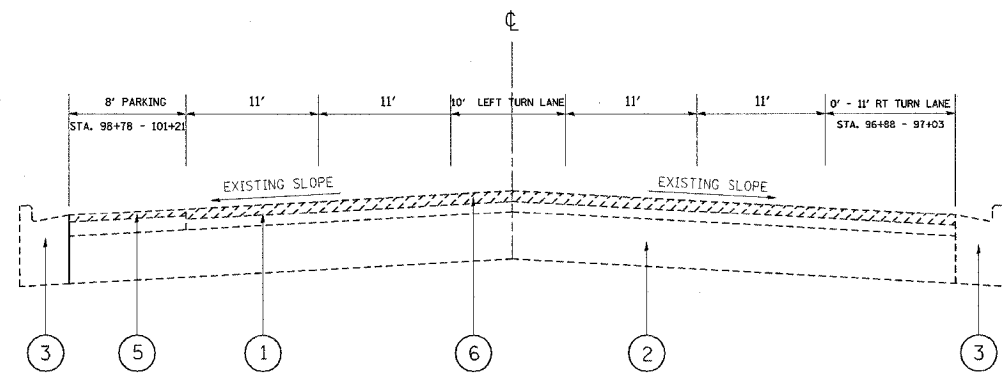

EXISTING TYPICAL CROSS SECTION
STA. 96+88 TO STA. 101+21

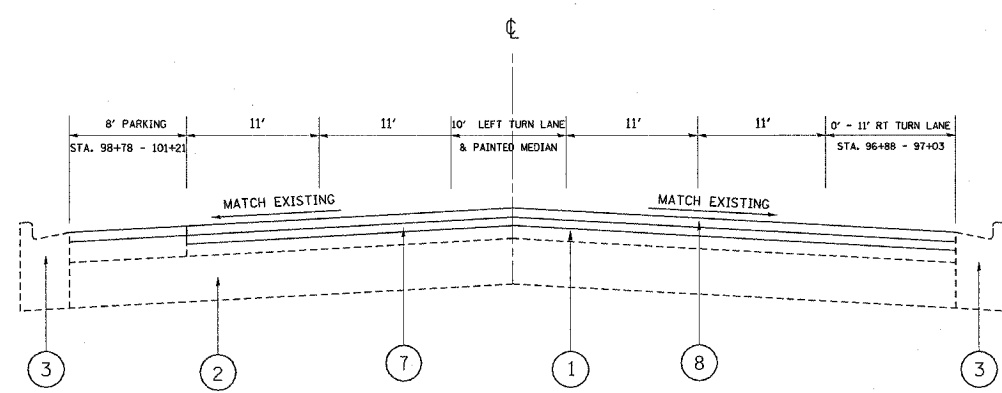

PROPOSED TYPICAL CROSS SECTION
STA. 96+88 TO STA. 101+21

LEGEND

- ① EXISTING HOT-MIX ASPHALT OVERLAY, 5" (±)
- ② EXISTING P.C.C. BASE COURSE, 10" (±)
- ③ EXISTING COMBINATION CONCRETE CURB & GUTTER
- ④ EXISTING RAISED MEDIAN
- ⑤ PROPOSED HOT-MIX ASPHALT SURFACE REMOVAL, 1 3/4" (PARKING LANES AND BRIDGE APPROACH SLAB)
- ⑥ PROPOSED HOT-MIX ASPHALT SURFACE REMOVAL, 2 1/2"
- ⑦ PROPOSED POLYMERIZED LEVELING BINDER (MM), IL-4.75, N50, (3/4")
- ⑧ PROPOSED POLYMERIZED HMA SURFACE COURSE, MIX "F", N90, (1 3/4")

DENOTES REMOVAL

REVISIONS	
NAME	DATE

ILLINOIS DEPARTMENT OF TRANSPORTATION
IL 31
EXISTING AND PROPOSED TYPICAL SECTIONS

SCALE: VERT. NONE
HORIZ. DATE 4/18/2007

DRAWN BY
CHECKED BY

CONTRACT: 60C64				
F.A.U. RTE.	SECTION	COUNTY	TOTAL SHEETS	SHEET NO.
3887	(E-1, P, G, H & R) RS-5	KANE	43	7
STA. +	TO STA. +			
FED. ROAD DIST. NO. 1	ILLINOIS	HIGHWAY PROJECT		

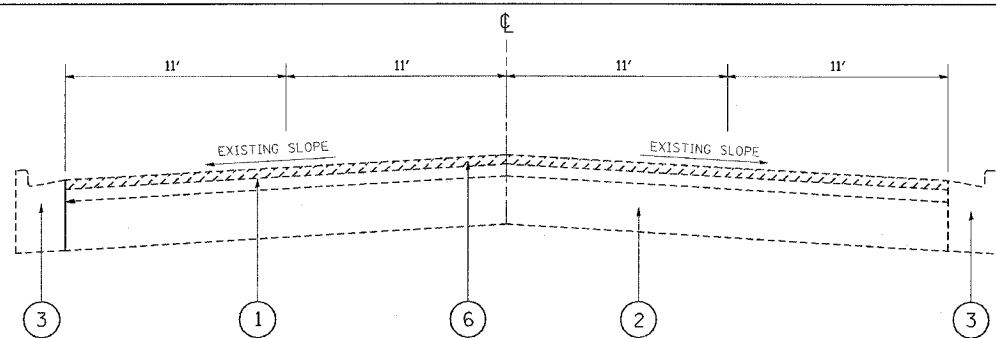

EXISTING TYPICAL CROSS SECTION
STA. 101+21 TO STA. 111+65

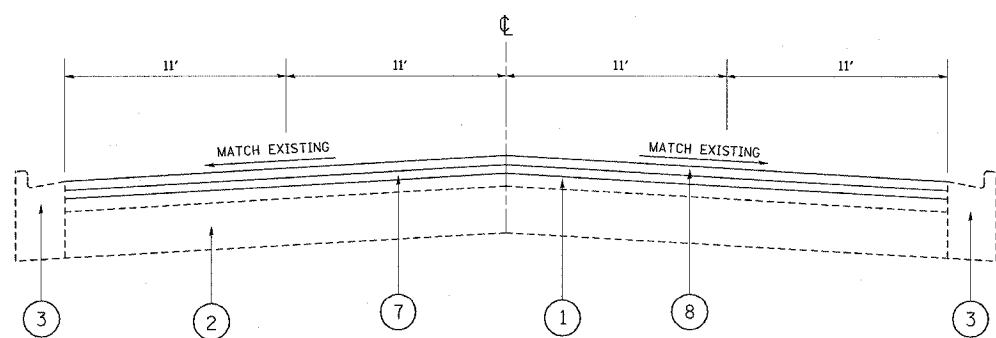

PROPOSED TYPICAL CROSS SECTION
STA. 101+21 TO STA. 111+65

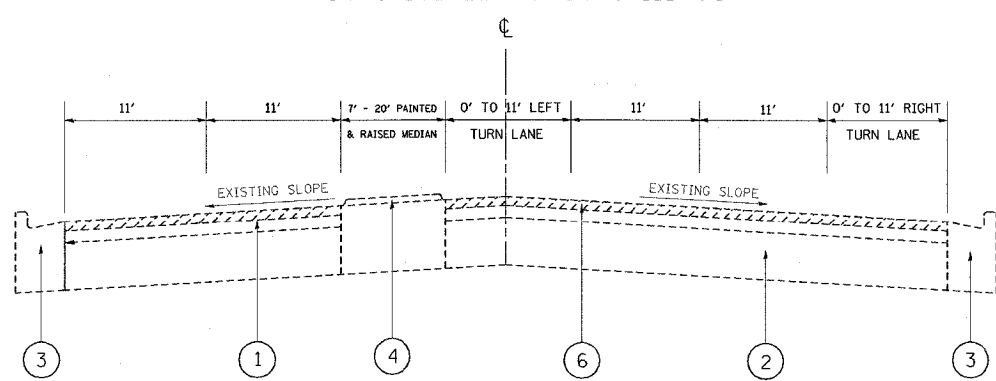

EXISTING TYPICAL CROSS SECTION
STA. 111+65 TO STA. 119+10

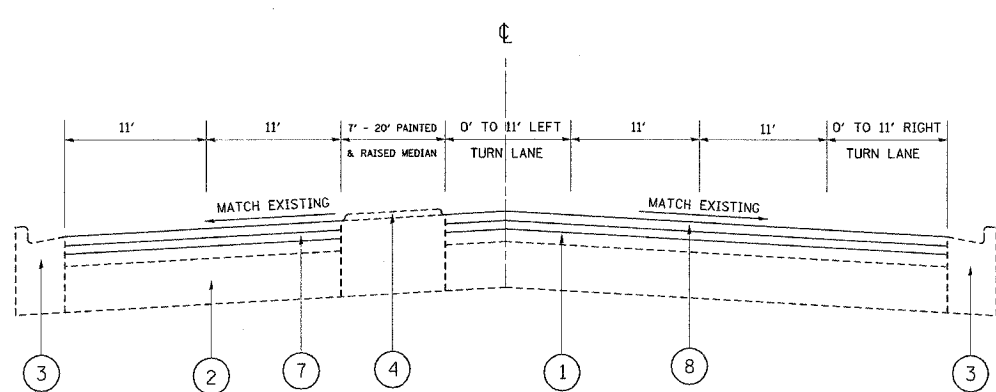

PROPOSED TYPICAL CROSS SECTION
STA. 111+65 TO STA. 119+10

LEGEND

- ① EXISTING HOT-MIX ASPHALT OVERLAY, 5" (±)
- ② EXISTING P.C.C. BASE COURSE, 10" (±)
- ③ EXISTING COMBINATION CONCRETE CURB & GUTTER
- ④ EXISTING RAISED MEDIAN
- ⑤ PROPOSED HOT-MIX ASPHALT SURFACE REMOVAL, 1 3/4" (PARKING LANES AND BRIDGE APPROACH SLAB)
- ⑥ PROPOSED HOT-MIX ASPHALT SURFACE REMOVAL, 2 1/2"
- ⑦ PROPOSED POLYMERIZED LEVELING BINDER (MM), IL-4.75, N50, (3/4")
- ⑧ PROPOSED POLYMERIZED HMA SURFACE COURSE, MIX "F", N90, (1 3/4")

DENOTES REMOVAL

REVISIONS	
NAME	DATE

ILLINOIS DEPARTMENT OF TRANSPORTATION
IL 31
EXISTING AND PROPOSED
TYPICAL SECTIONS
SCALE: VERT. NONE
 HORIZ. DRAWN BY
DATE 4/18/2007 CHECKED BY

CONTRACT: 60C64				
F.A.U. RTE.	SECTION	COUNTY	TOTAL SHEETS	SHEET NO.
3887	(E-1, P, G, H & R) RS-5	KANE	43	8
STA. +	TO STA. +			
FED. ROAD DIST. NO. 1	ILLINOIS	HIGHWAY PROJECT		

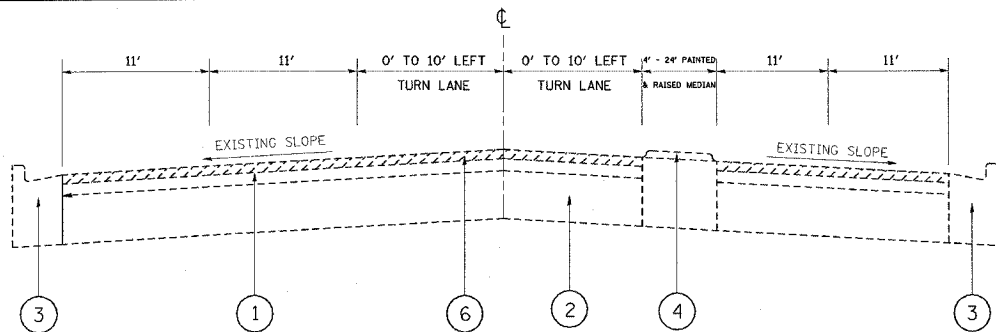

EXISTING TYPICAL CROSS SECTION
STA. 119+10 TO STA. 127+50

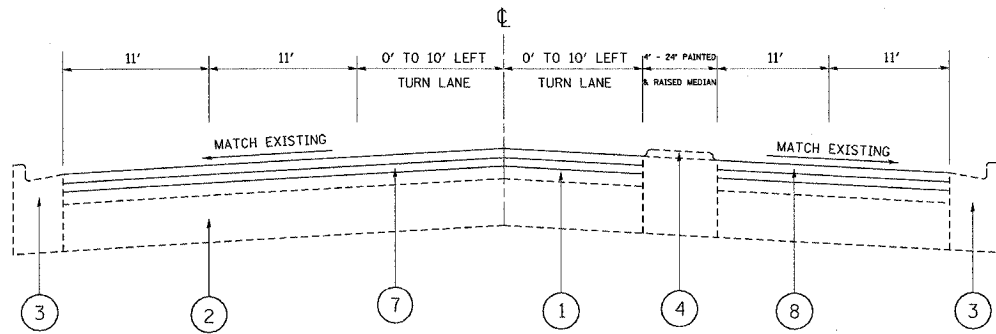

PROPOSED TYPICAL CROSS SECTION
STA. 119+10 TO STA. 127+50

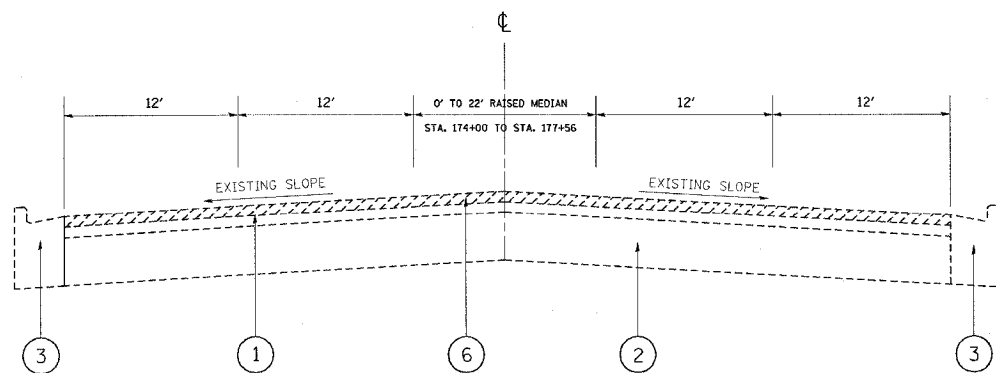

EXISTING TYPICAL CROSS SECTION
STA. 127+50 TO STA. 178+00

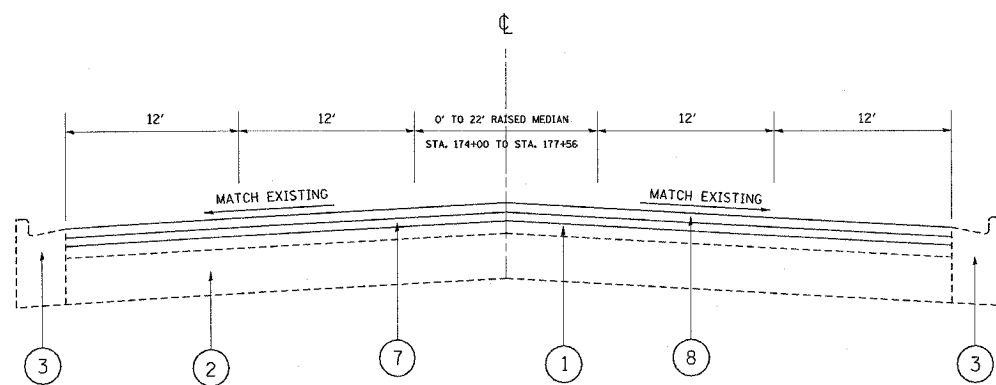

PROPOSED TYPICAL CROSS SECTION
STA. 127+50 TO STA. 178+00

LEGEND

- ① EXISTING HOT-MIX ASPHALT OVERLAY, 5" (±)
- ② EXISTING P.C.C. BASE COURSE, 10" (±)
- ③ EXISTING COMBINATION CONCRETE CURB & GUTTER
- ④ EXISTING RAISED MEDIAN
- ⑤ PROPOSED HOT-MIX ASPHALT SURFACE REMOVAL, 1 3/4" (PARKING LANES AND BRIDGE APPROACH SLAB)
- ⑥ PROPOSED HOT-MIX ASPHALT SURFACE REMOVAL, 2 1/2"
- ⑦ PROPOSED POLYMERIZED LEVELING BINDER (MM), IL-4.75, N50, (3/4")
- ⑧ PROPOSED POLYMERIZED HMA SURFACE COURSE, MIX "F", N90, (1 3/4")

DENOTES REMOVAL

REVISIONS	
NAME	DATE

ILLINOIS DEPARTMENT OF TRANSPORTATION
IL 31
EXISTING AND PROPOSED
TYPICAL SECTIONS
SCALE: VERT. NONE
HORIZ. DATE 4/18/2007
DRAWN BY
CHECKED BY

CONTRACT: 60C64			
F.A.U. RTE.	SECTION	COUNTY	TOTAL SHEETS
3887	(E-1, P, G, H & R) RS-5	KANE	43
STA. +	TO STA. +		
FED. ROAD DIST. NO. 1	ILLINOIS	HIGHWAY PROJECT	

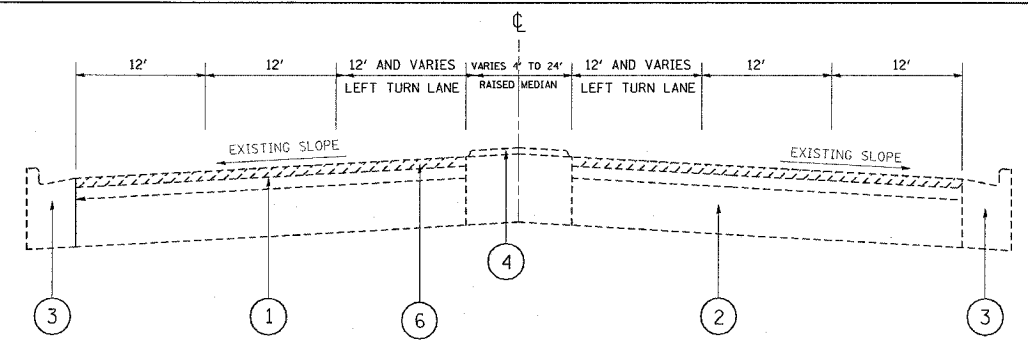

EXISTING TYPICAL CROSS SECTION
STA. 178+00 TO STA. 248+19

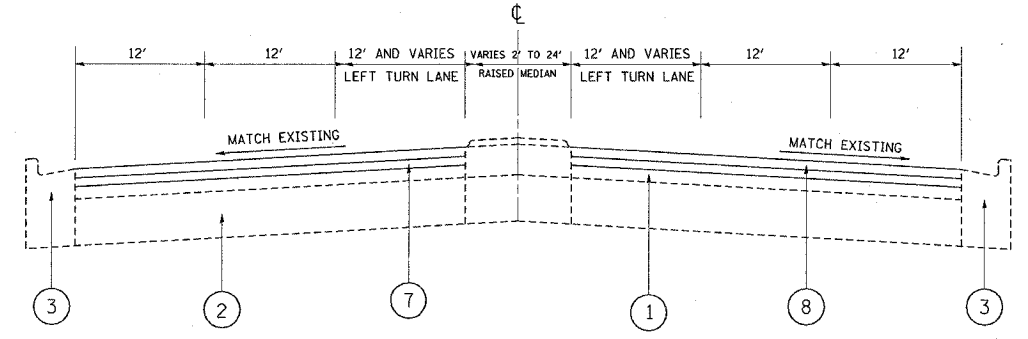

PROPOSED TYPICAL CROSS SECTION
STA. 178+00 TO STA. 248+19

LEGEND

- ① EXISTING HOT-MIX ASPHALT OVERLAY, 5" (±)
- ② EXISTING P.C.C. BASE COURSE, 10" (±)
- ③ EXISTING COMBINATION CONCRETE CURB & GUTTER
- ④ EXISTING RAISED MEDIAN
- ⑤ PROPOSED HOT-MIX ASPHALT SURFACE REMOVAL, 1 3/4" (PARKING LANES AND BRIDGE APPROACH SLAB)
- ⑥ PROPOSED HOT-MIX ASPHALT SURFACE REMOVAL, 2 1/2"
- ⑦ PROPOSED POLYMERIZED LEVELING BINDER (MM), IL-4.75, N50, (3/4")
- ⑧ PROPOSED POLYMERIZED HMA SURFACE COURSE, MIX "F", N90, (1 3/4")

DENOTES REMOVAL

REVISIONS	
NAME	DATE

ILLINOIS DEPARTMENT OF TRANSPORTATION

IL 31
EXISTING AND PROPOSED
TYPICAL SECTIONS

VERT. NONE
SCALE: HORIZ.
DATE 4/18/2007

DRAWN BY
CHECKED BY

F.A.U. RTE.	SECTION	COUNTY	TOTAL SHEETS	SHEET NO.
3887	E-1, P, G, H & R/ RS-5	KANE	43	10
STA. 10+88 TO STA. 39+00		FED. ROAD DIST. NO. 1 ILLINOIS HIGHWAY PROJECT		

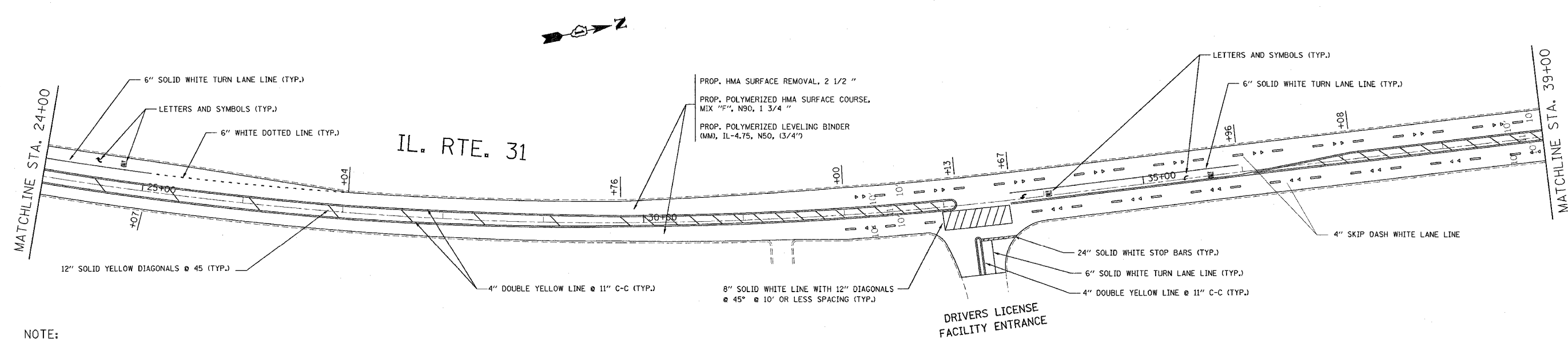
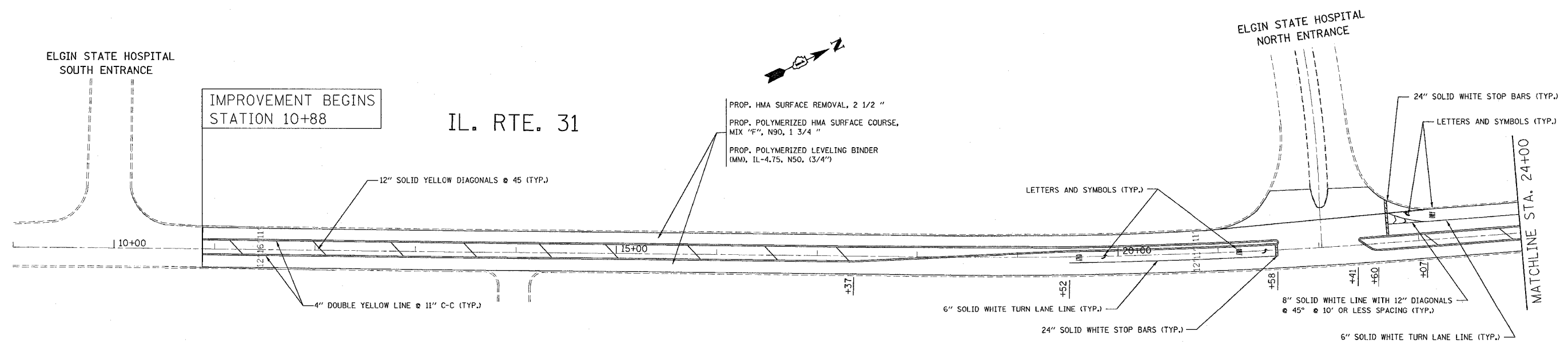

NOTE:

LIMIT OF RESURFACING ON SIDE ROADS AND STREETS SHALL BE TO THE RADIUS OF RETURN (WHERE APPLICABLE) OR AS DIRECTED BY THE ENGINEER.

ALL PERMANENT PAVEMENT MARKINGS SHALL BE THERMOPLASTIC UNLESS OTHERWISE NOTED. SEE "DISTRICT ONE TYPICAL PAVEMENT MARKINGS" DETAIL (TC-13)

RAISED REFLECTIVE PAVEMENT MARKERS SHALL BE USED THROUGH THE IMPROVEMENT LIMITS. SEE "DISTRICT ONE TYPICAL APPLICATIONS RAISED REFLECTIVE PAVEMENT MARKERS" DETAIL (TC-11)

REVISIONS	
NAME	DATE

ILLINOIS DEPARTMENT OF TRANSPORTATION
 IL 31: ELGIN STATE HOSPITAL SOUTH ENTRANCE TO TOLLGATE RD.
 ROADWAY & PAVEMENT MARKING PLANS

SCALE: VERT. 1"=50'
 HORIZ. 1"=50'
 DATE 4/18/2007

DRAWN BY
 CHECKED BY

F.A.U. RTE.	SECTION	COUNTY	TOTAL SHEETS	SHEET NO.
3887	E-1, P, G, H & R1 R5-5	KANE	43	11
STA. 39+00 TO STA. 67+00		FED. ROAD DIST. NO. 1 ILLINOIS HIGHWAY PROJECT		



IL. RTE. 31

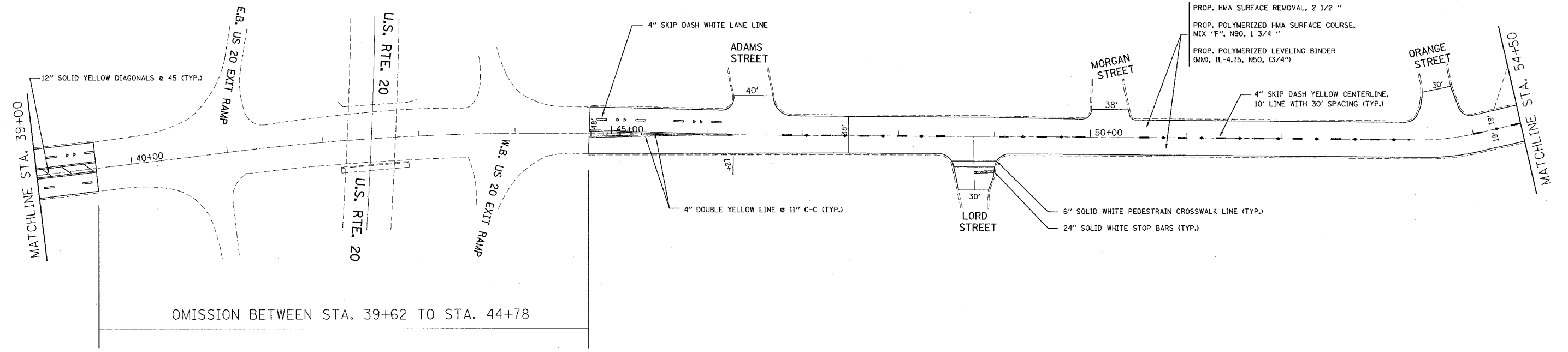

OMISSION BETWEEN STA. 39+62 TO STA. 44+78

IL RTE. 31

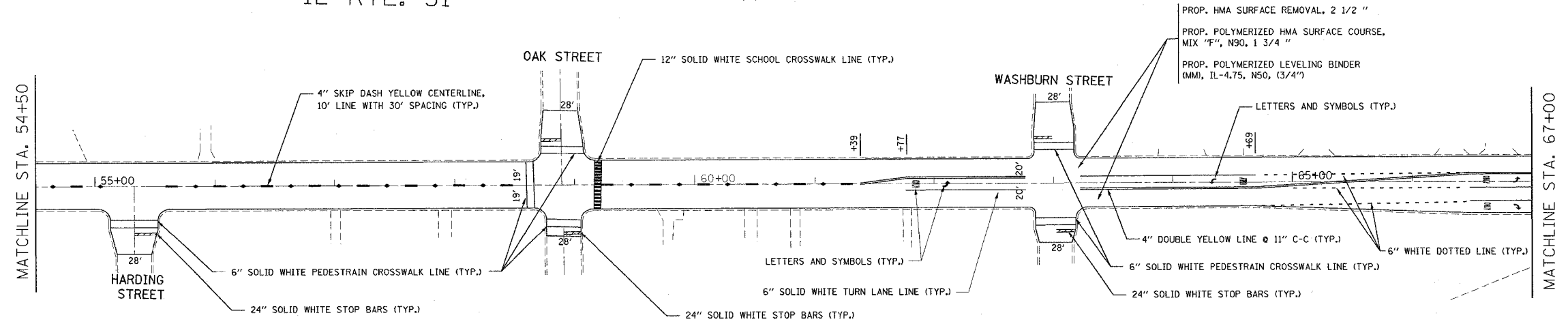
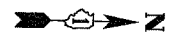

PLOT DATE = 4/18/2007
 FILE NAME = c:\pav\elg\elg31\elg31.dwg
 USER NAME = j...

REVISIONS	
NAME	DATE

ILLINOIS DEPARTMENT OF TRANSPORTATION

IL 31: ELGIN STATE HOSPITAL SOUTH ENTRANCE TO TOLLGATE RD.

ROADWAY & PAVEMENT MARKING PLANS

SCALE: VERT. 1"=50'
 HORIZ. 1"=50'
 DATE 4/18/2007

DRAWN BY
 CHECKED BY

F.A.U. RTE.	SECTION	COUNTY	TOTAL SHEETS	SHEET NO.
3887	(E-1, P, G, H & R) RS-5	KANE	43	12
STA. 67+00 TO STA. 93+00				
FED. ROAD DIST. NO. 1		ILLINOIS	HIGHWAY PROJECT	

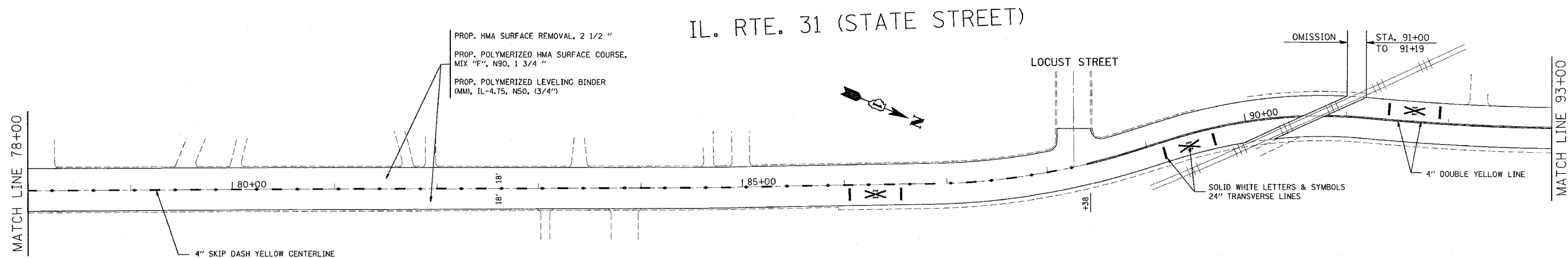
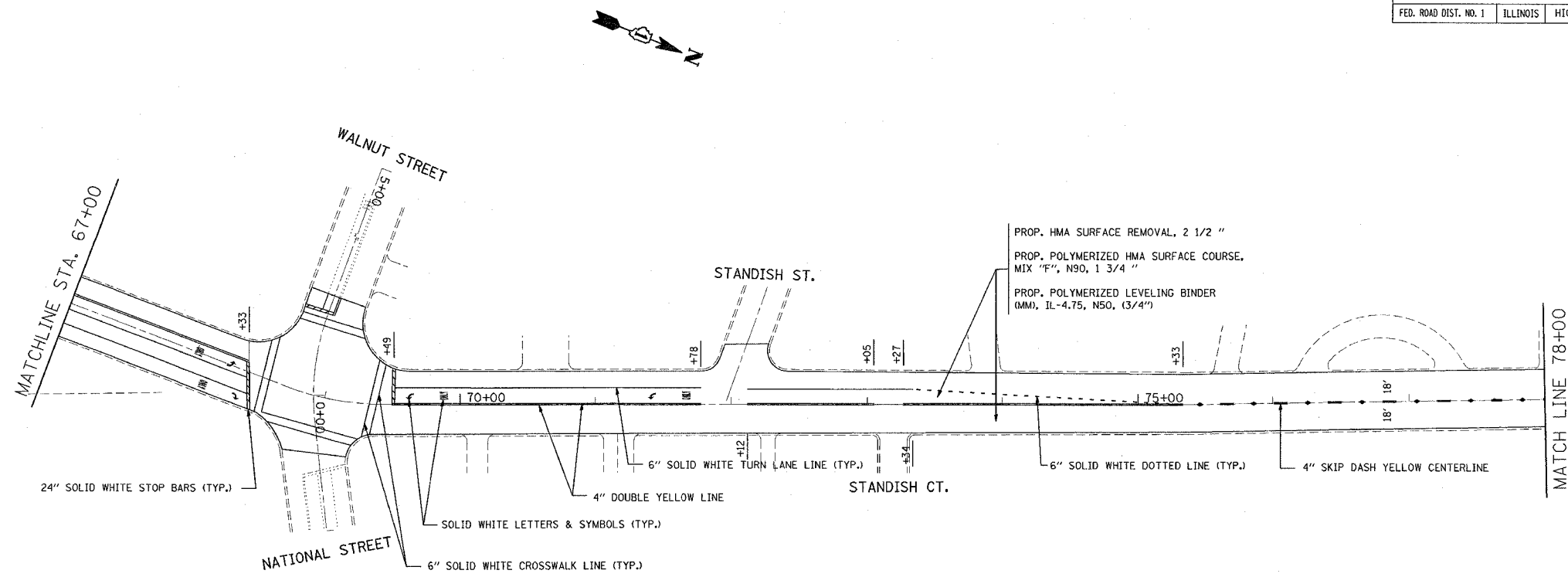

PLOT DATE = 4/19/2007
 PLOT SCALE = 1/8" = 1'-0"
 PLOT SIZE = 11" x 17"
 USER NAME = brcat

REVISIONS	
NAME	DATE

ILLINOIS DEPARTMENT OF TRANSPORTATION

IL 31: ELGIN STATE HOSPITAL SOUTH ENTRANCE TO TOLLGATE RD.

ROADWAY & PAVEMENT MARKING PLANS

SCALE: VERT. _____
 DATE: _____

DRAWN BY _____
 CHECKED BY _____

F.A.U. RTE.	SECTION	COUNTY	TOTAL SHEETS	SHEET NO.
3887	(E-1, P, G, H & R) RS-5	KANE	43	13
STA. 93+00		TO STA. 123+00		
FED. ROAD DIST. NO. 1		ILLINOIS	HIGHWAY PROJECT	

IL. RTE. 31 (STATE STREET)

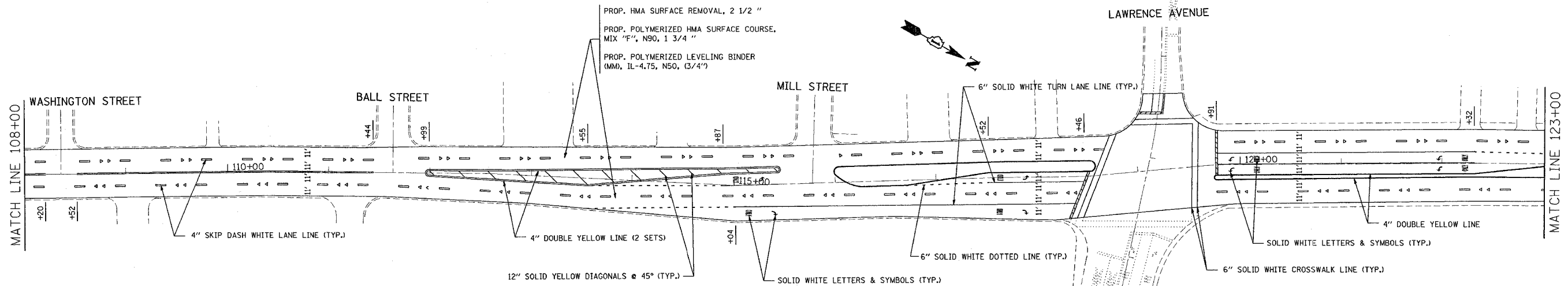
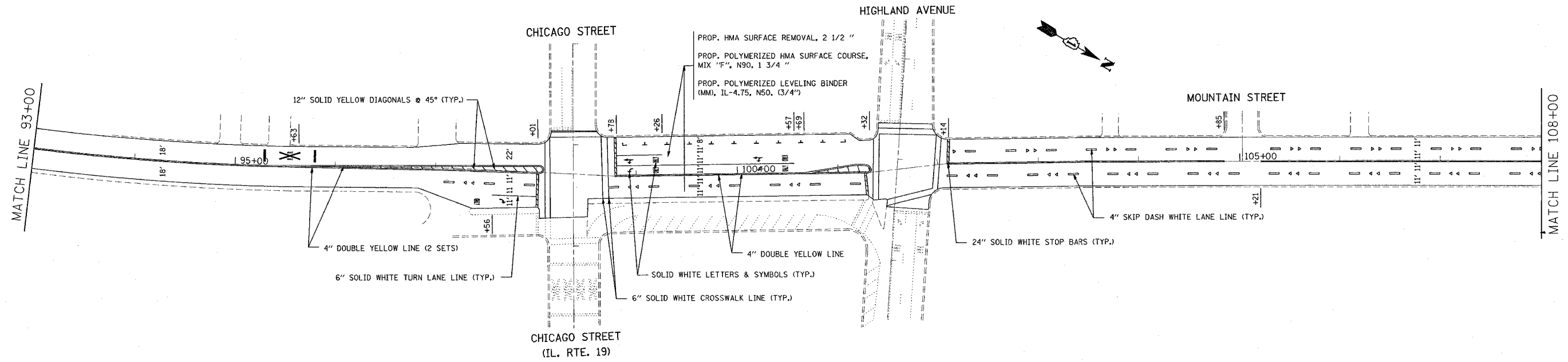

PLOT DATE = 4/18/2007
 FILE NAME = c:\projects\60c64\123007\sh_rday.dgn
 PLOT SCALE = 80.0000' / 1" IN.
 USER NAME = tgrant

REVISIONS	
NAME	DATE

ILLINOIS DEPARTMENT OF TRANSPORTATION
 IL 31: ELGIN STATE HOSPITAL SOUTH
 ENTRANCE TO TOLLGATE RD.
 ROADWAY & PAVEMENT MARKING PLANS
 SCALE: VERT. DRAWN BY
 DATE: HORIZ. CHECKED BY

CONTRACT NO. 60C64				
F.A.I.L. RTE.	SECTION	COUNTY	TOTAL SHEETS	SHEET NO.
3887	E-1, P, G, H & RJ RS-5	KANE	43	14
STA. 123+00		TO STA. 153+00		
FED. ROAD DIST. NO. 1	ILLINOIS	HIGHWAY PROJECT		

IL. RTE. 31 (STATE STREET)

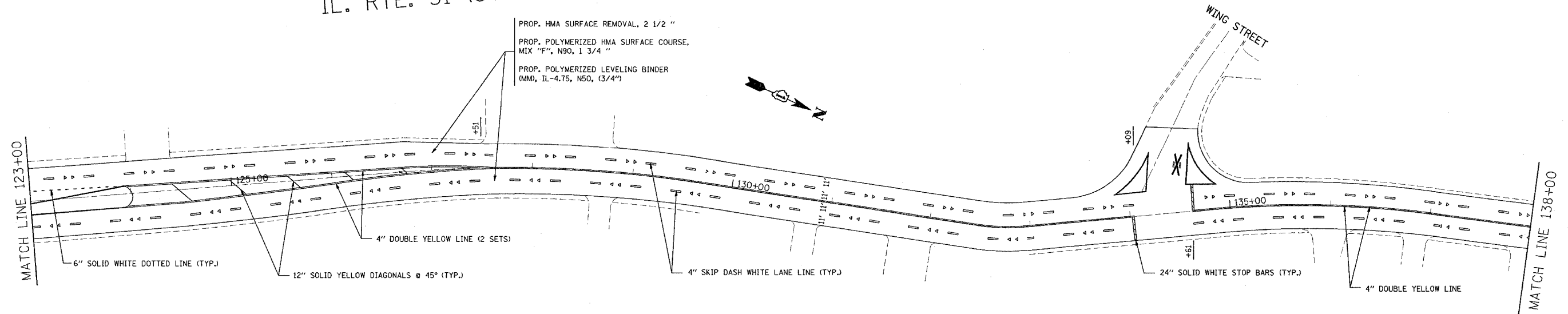

IL. RTE. 31 (STATE STREET)

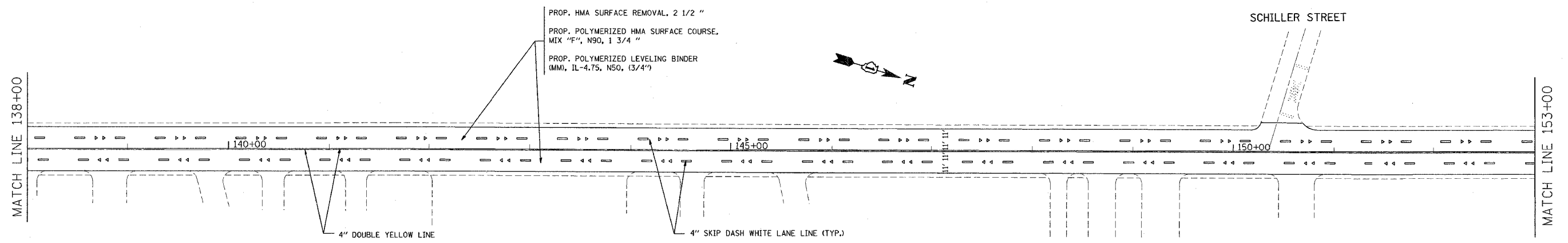

PLOT DATE = 4/15/2007
 PLOT SCALE = 800/8000 = 1/10
 USER NAME = srent

REVISIONS	
NAME	DATE

ILLINOIS DEPARTMENT OF TRANSPORTATION

IL 31: ELGIN STATE HOSPITAL SOUTH ENTRANCE TO TOLLGATE RD.

ROADWAY & PAVEMENT MARKING PLANS

SCALE: VERT. _____
 HORIZ. _____

DATE _____ DRAWN BY _____
 CHECKED BY _____

CONTRACT NO. 60C64				
F.A.U. RTE.	SECTION	COUNTY	TOTAL SHEETS	SHEET NO.
3887	(E-1, P, G, H & R) RS-5	KANE	43	15
STA. 153+00		TO STA. 183+00		
FED. ROAD DIST. NO. 1		ILLINOIS	HIGHWAY PROJECT	

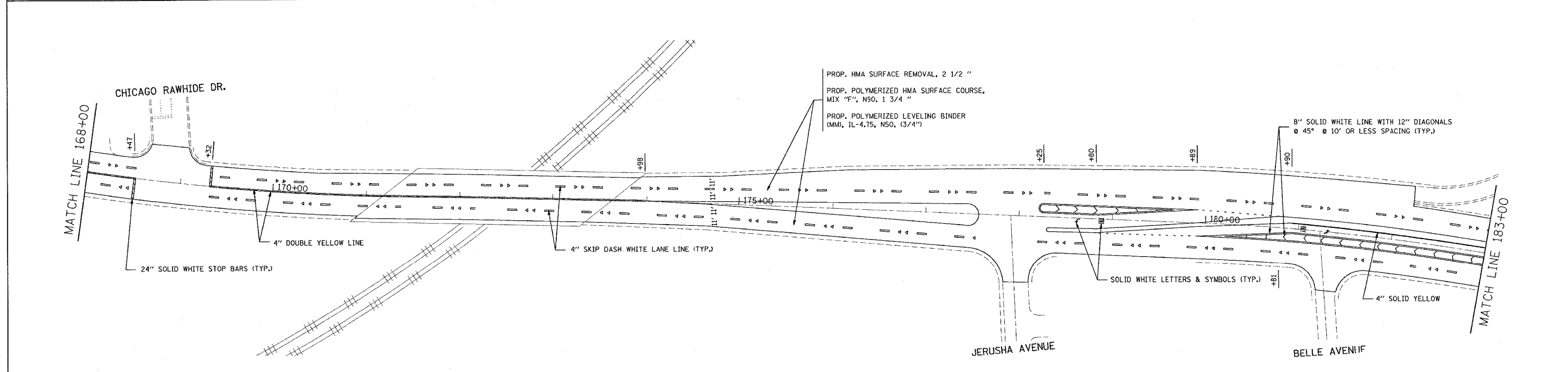
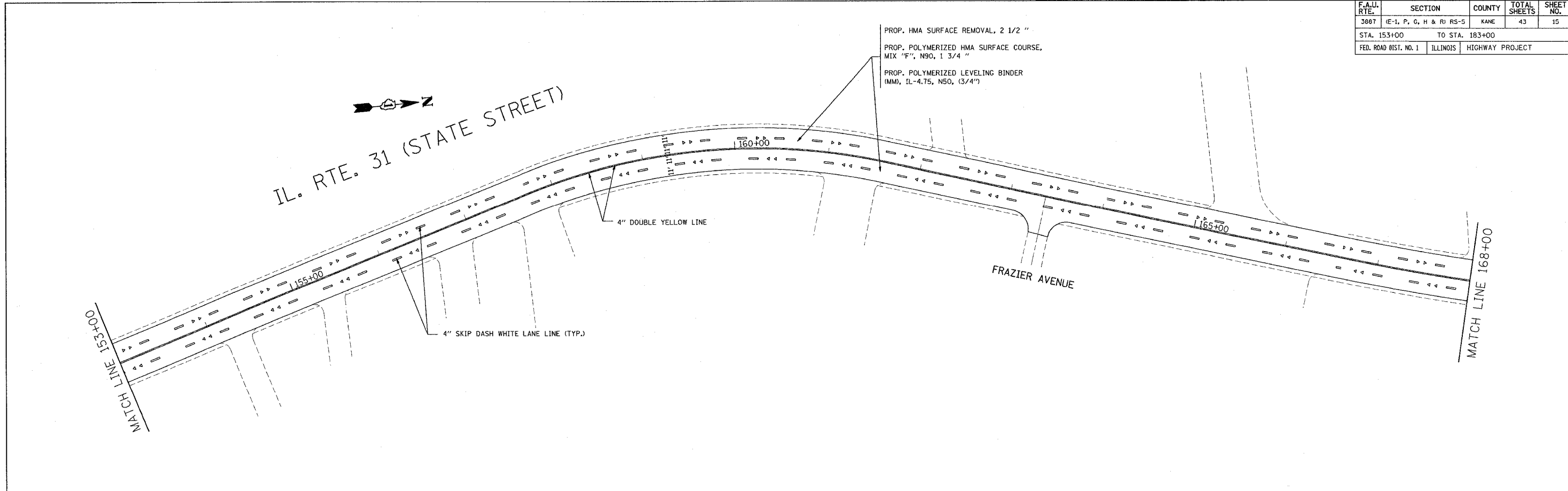

PLOT DATE = 4/18/2007
 FILE NAME = c:\p\projects\125687\11_rdw.dgn
 PLOT SCALE = 3/8" = 1'-0"
 USER NAME = dwg1

REVISIONS		ILLINOIS DEPARTMENT OF TRANSPORTATION
NAME	DATE	
		IL 31: ELGIN STATE HOSPITAL SOUTH ENTRANCE TO TOLLGATE RD. ROADWAY & PAVEMENT MARKING PLANS
SCALE: VERT. _____		DRAWN BY _____
DATE _____		

F.A.U. RTE.	SECTION	COUNTY	TOTAL SHEETS	SHEET NO.
3887	E-1, P, G, H & R) RS-5	KANE	43	16
STA. 183+00 TO STA. 213+00		FED. ROAD DIST. NO. 1 ILLINOIS HIGHWAY PROJECT		

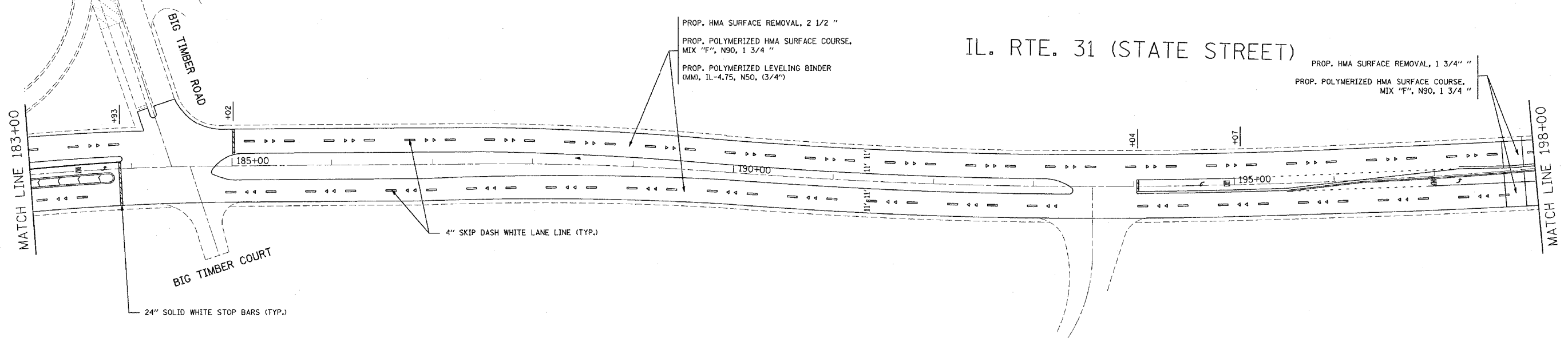

NOTE: THE CONTRACTOR SHALL MILL ONLY 3/4" FOR THE TWO APPROACH SLABS OF THE BRIDGE OVER TYLER CREEK (STA. 197+69 TO STA. 197+89) AND (STA. 198+27 TO STA. 198+47).

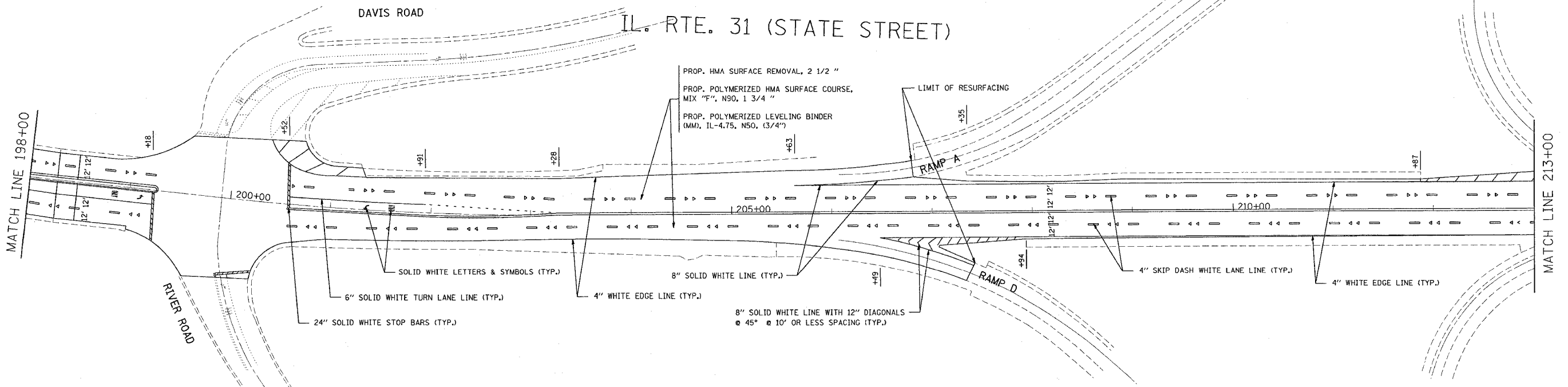
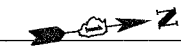

NOTE: THE CONTRACTOR SHALL MILL ONLY 3/4" FOR THE TWO APPROACH SLABS OF THE BRIDGE OVER TYLER CREEK (STA. 197+69 TO STA. 197+89) AND (STA. 198+27 TO STA. 198+47).

REVISIONS	
NAME	DATE

ILLINOIS DEPARTMENT OF TRANSPORTATION
 IL 31: ELGIN STATE HOSPITAL SOUTH ENTRANCE TO TOLLGATE RD.
 ROADWAY & PAVEMENT MARKING PLANS
 SCALE: VERT. _____ HORIZ. _____
 DATE _____ DRAWN BY _____ CHECKED BY _____

PLOT DATE = 4/18/2007
 FILE NAME = c:\p\o\m\c\m\dl25687\h_r\pav\pav.dgn
 PLOT SCALE = 50.0000 / IN.
 USER NAME = grant

CONTRACT NO. 60C64				
F.A.U. RTE.	SECTION	COUNTY	TOTAL SHEETS	SHEET NO.
3887	(E-1, P, G, H & R) RS-5	KANE	43	17
STA. 213+00		TO STA. 243+00		
FED. ROAD DIST. NO. 1		ILLINOIS	HIGHWAY PROJECT	

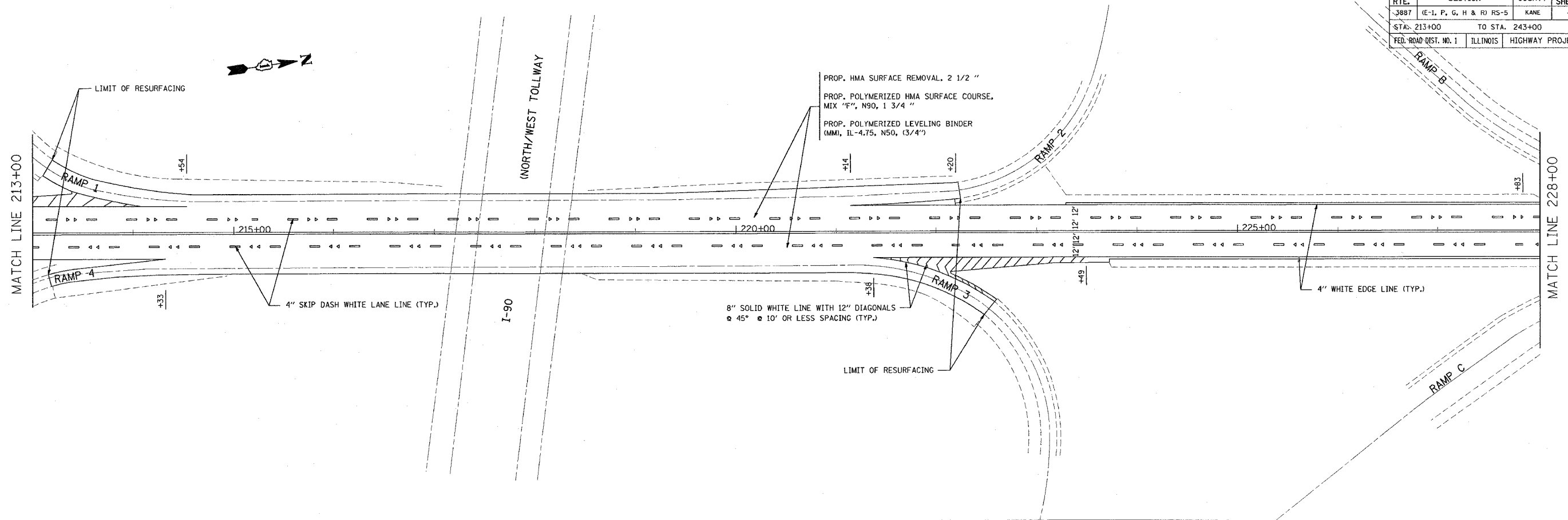

IL. RTE. 31 (STATE STREET)

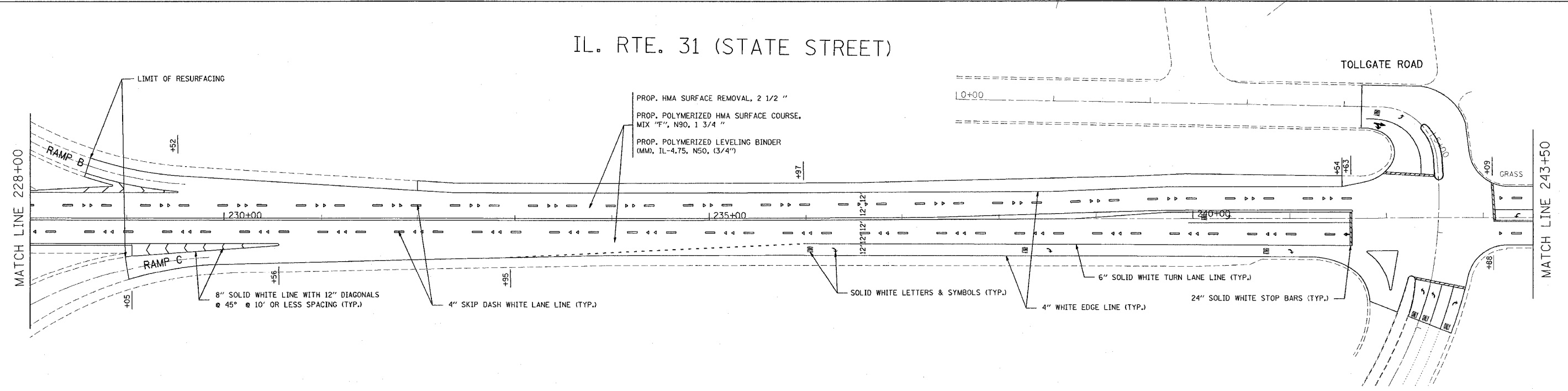

REVISIONS	
NAME	DATE

ILLINOIS DEPARTMENT OF TRANSPORTATION

IL 31: ELGIN STATE HOSPITAL SOUTH ENTRANCE TO TOLLGATE RD.

ROADWAY & PAVEMENT MARKING PLANS

SCALE: VERT. _____
 DATE _____

DRAWN BY _____
 CHECKED BY _____

PLOT DATE = 4/16/2007
 PLOT SCALE = 1/8" = 1'-0"
 USER NAME = ttrans1

F.A.U. RTE.	SECTION	COUNTY	TOTAL SHEETS	SHEET NO.
3887	(E-1, P, G, H & R) RS-5	KANE	43	18
STA. 243+00		TO STA. 248+19		
FED. ROAD DIST. NO. 1		ILLINOIS	HIGHWAY PROJECT	

IL. RTE. 31 (STATE STREET)

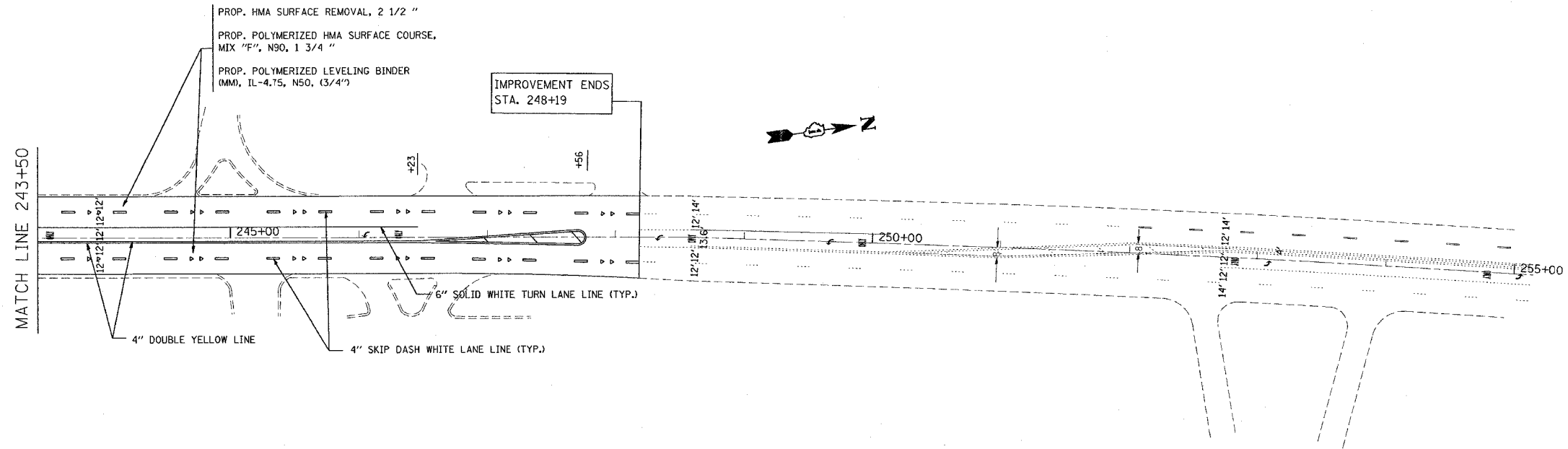

PROP. HMA SURFACE REMOVAL, 2 1/2 \"

PROP. POLYMERIZED HMA SURFACE COURSE, MIX \"F\", N90, 1 3/4 \"

PROP. POLYMERIZED LEVELING BINDER (MM), IL-4.75, N50, (3/4\")

IMPROVEMENT ENDS STA. 248+19



MATCH LINE 243+50

4\"/>

4\"/>

6\"/>

PLOT DATE = 4/18/2007
 FILE NAME = c:\p\proj\31\24350\24350.dgn
 PLOT SCALE = 50.0000 / IN.
 USER NAME = grant

REVISIONS	
NAME	DATE

ILLINOIS DEPARTMENT OF TRANSPORTATION

IL 31: ELGIN STATE HOSPITAL SOUTH ENTRANCE TO TOLLGATE RD.

ROADWAY & PAVEMENT MARKING PLANS

SCALE: VERT. DRAWN BY
 HORIZ. CHECKED BY

DATE

F.A.U. RTE.	SECTION	COUNTY	TOTAL SHEETS	SHEET NO.
3887	(E-1,P,G,H&R)RS-5	KANE	43	19
STA.		TO STA.		
FED. ROAD DIST. NO.	ILLINOIS	FED. AID PROJECT		

GENERAL NOTES

Plan dimensions and details relative to existing plans are subject to routine variations. The Contractor shall field verify existing dimensions and details affecting new construction and make necessary approved adjustments prior to construction or ordering of materials. Such variations shall not be cause for additional compensation for a change in scope of the work, however, the Contractor will be paid for the quantity actually furnished based upon the unit price bid for the work.

Care shall be taken not to damage the existing floor drains. Overlay shall be sloped to drain as required.

The sidewalk under the bridge shall be closed per Highway Std 701801 while the Contractor is working on the bridge.

Polyurea Pavement Markings shall not be placed until the final pavement markings are to be placed on the roadway. The Polyurea pavement markings shall align with the final pavement markings. Until the final pavement markings can be placed, Temporary Pavement Markings shall be used and match the alignment of the existing pavement markings.

TOTAL BILL OF MATERIAL

ITEM	UNIT	TOTAL
Protective Coat	SQ YD	287
Hot-Mix Asphalt Surface Removal (Deck)	SQ YD	287
Bridge Deck Grooving	SQ YD	270
Raised Reflective Pavement Marker (Bridge)	EACH	5
Raised Reflective Pavement Marker Removal	EACH	5
Silicone Joint Sealer, 1/2"	FOOT	37
Bridge Deck Latex Concrete Overlay, 2 1/2"	SQ YD	287
Bridge Deck Hydro-scarification 1/2"	SQ YD	287

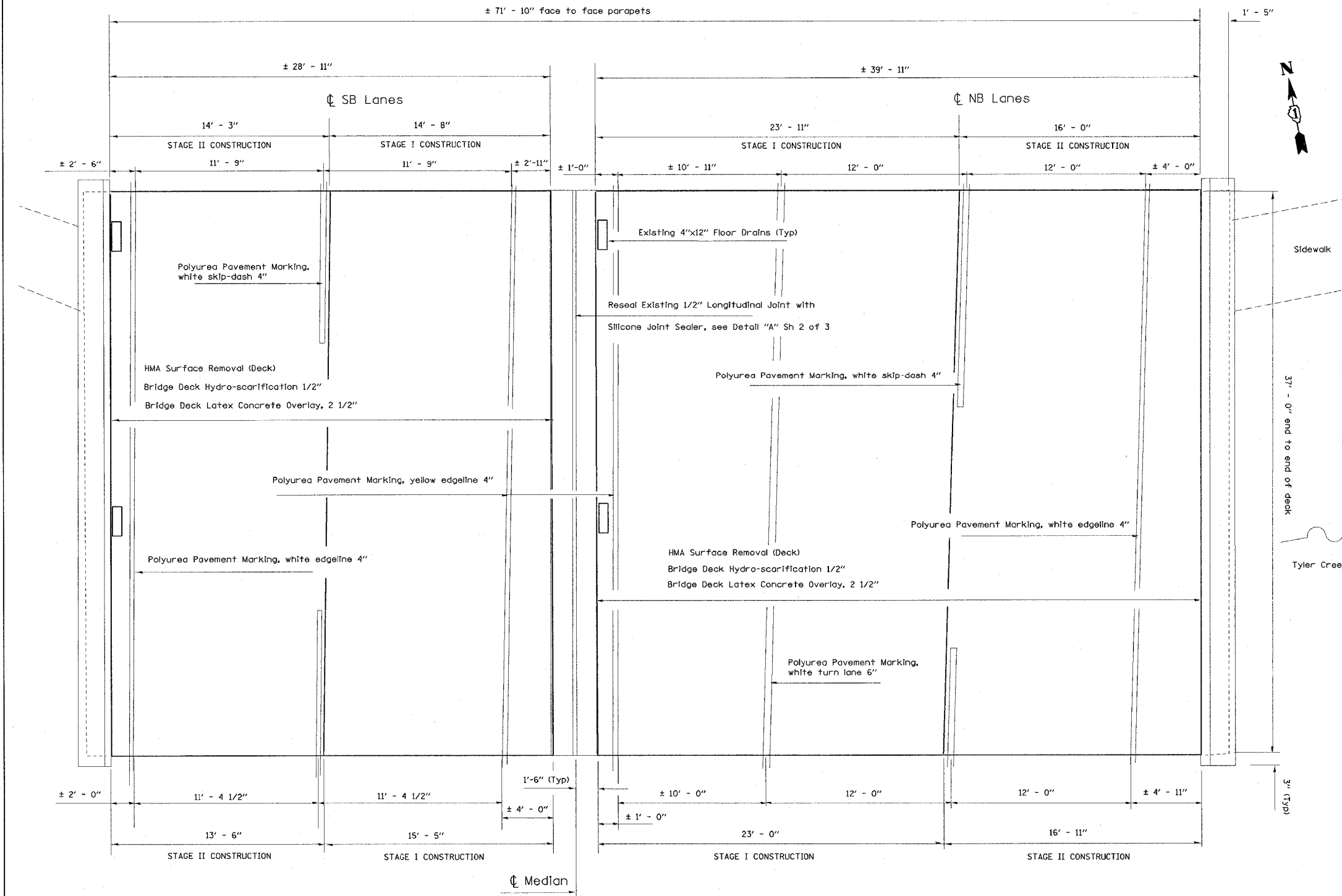

DECK PLAN

DATE OF SURVEY 3/12/2007 S. WILSON

PLOT DATE = 4/18/2007
 PLOT SCALE = 50' = 1" IN.
 USER NAME = lbarrett

REVISIONS		ILLINOIS DEPARTMENT OF TRANSPORTATION
NAME	DATE	
		IL 31 OVER TYLER CREEK SN 045-0015 BRIDGE REPAIR PLANS

SCALE: VERT. _____
 HORIZ. _____
 DATE _____ DRAWN BY _____
 CHECKED BY _____

F.A.U. RTE.	SECTION	COUNTY	TOTAL SHEETS	SHEET NO.
3887	IE-LP,G,H&RIS-5	KANE	43	20
STA.	TO STA.			
FED. ROAD DIST. NO.	ILLINOIS	FED. AID PROJECT		

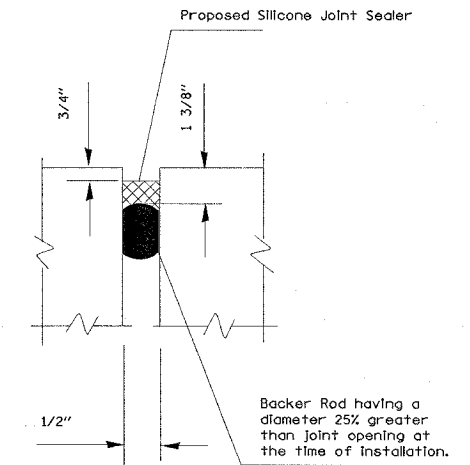
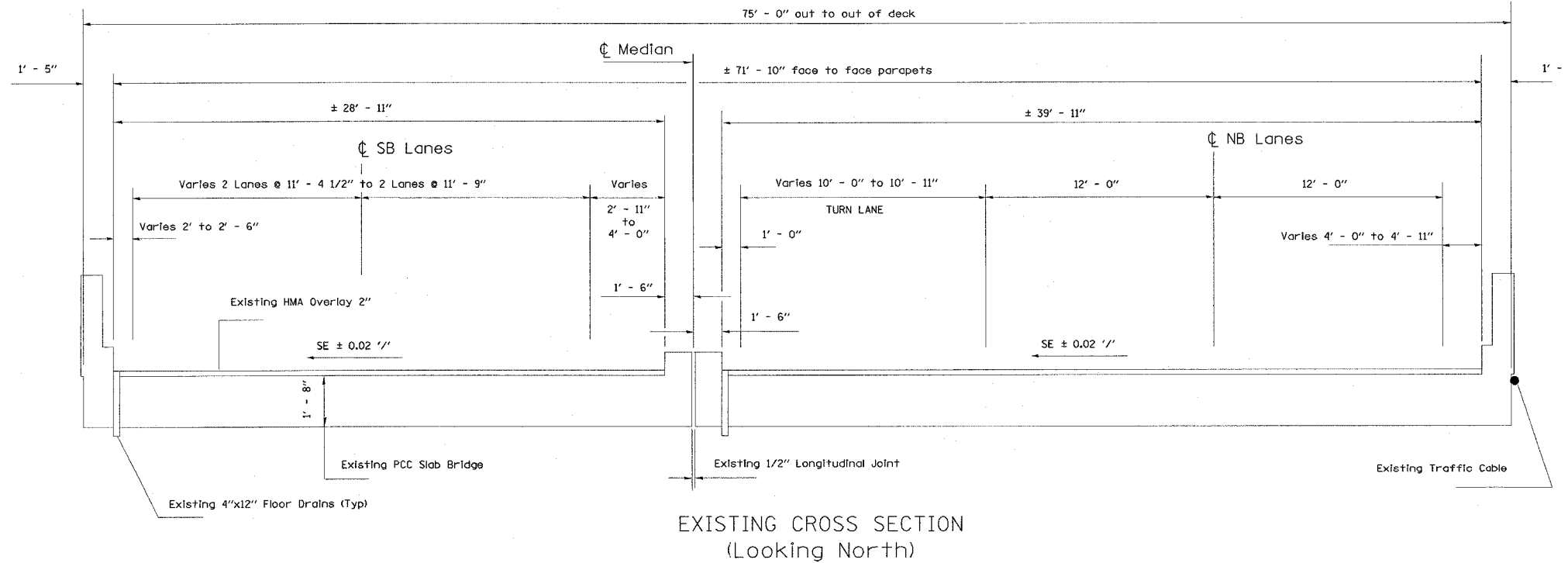

Removal of existing Hot-poured Joint Filler Elastic Type is Included in the cost of the Silicone Joint Sealer

DETAIL "A"

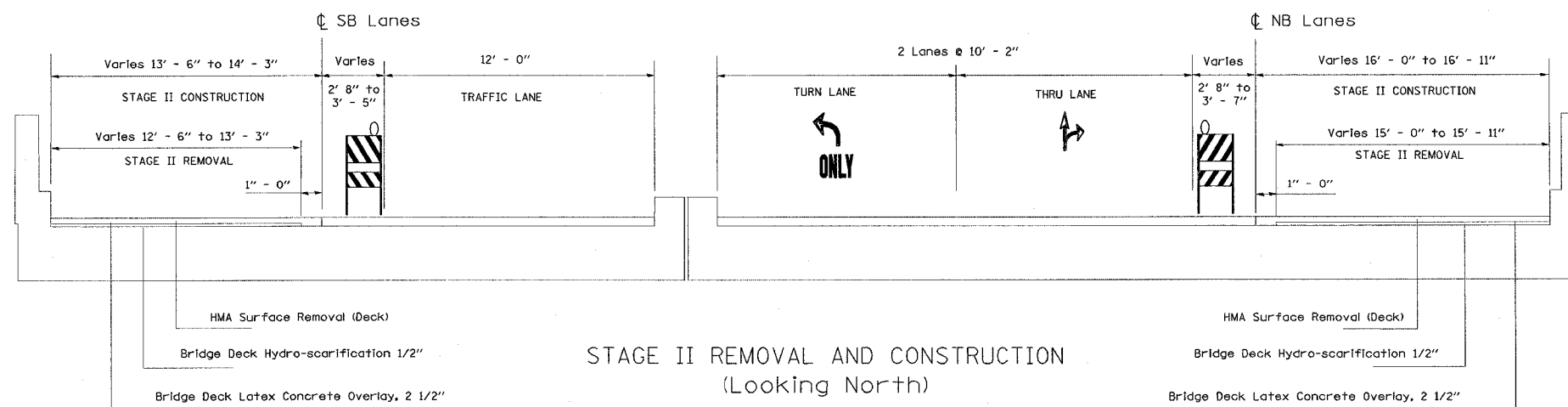
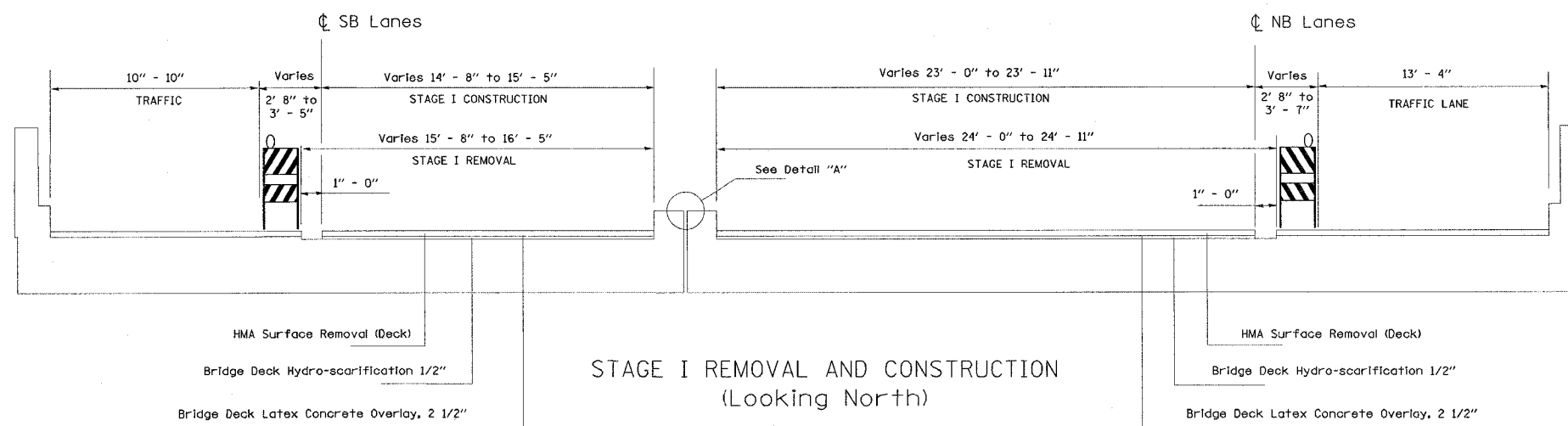

REVISIONS	
NAME	DATE

ILLINOIS DEPARTMENT OF TRANSPORTATION

IL 31 OVER TYLER CREEK

SN 045-0015

CROSS SECTIONS

STAGE CONSTRUCTION

SCALE: VERT. DATE

HORIZ. DATE

DRAWN BY

CHECKED BY

PLOT DATE = 4/19/2007

PLOT SCALE = 50,000 / IN

USER NAME = benort

F.A.U. RTE.	SECTION	COUNTY	TOTAL SHEETS	SHEET NO.
3887	IE-LP,G,H&RIS-5	KANE	43	21
STA.	TO STA.			
FED. ROAD DIST. NO.	ILLINOIS	FED. AID PROJECT		

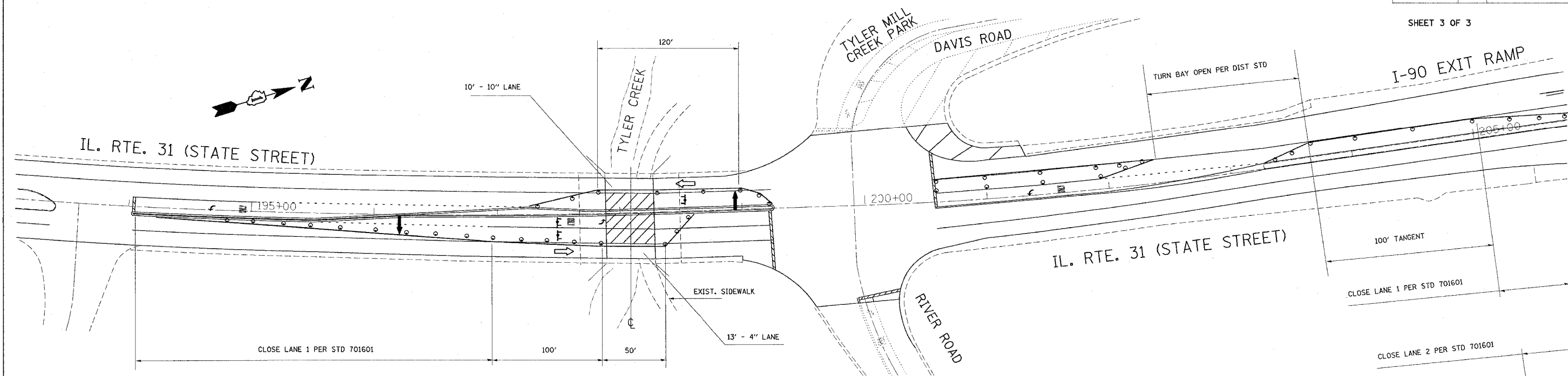

STAGE I CONSTRUCTION

- WORK ZONE
- DIRECTION OF TRAFFIC
- SIGN
- ARROW BOARD
- TYPE III BARRICADES W/ STEADY BURN LIGHTS
- DRUMS WITH STEADY BURN MONODIRECTIONAL LIGHTS
50' CTS ON TANGENT
25' CTS ON TAPER

COVER EXISTING CONFLICTING PAVEMENT MARKINGS WITH BLACK TYPE III TAPE. UNLESS SPECIFIED ELSEWHERE, THE COST OF THE TYPE III TAPE AND ITS REMOVAL IS INCLUDED IN THE COST OF "TRAFFIC CONTROL & PROTECTION 701601 (SPECIAL)".

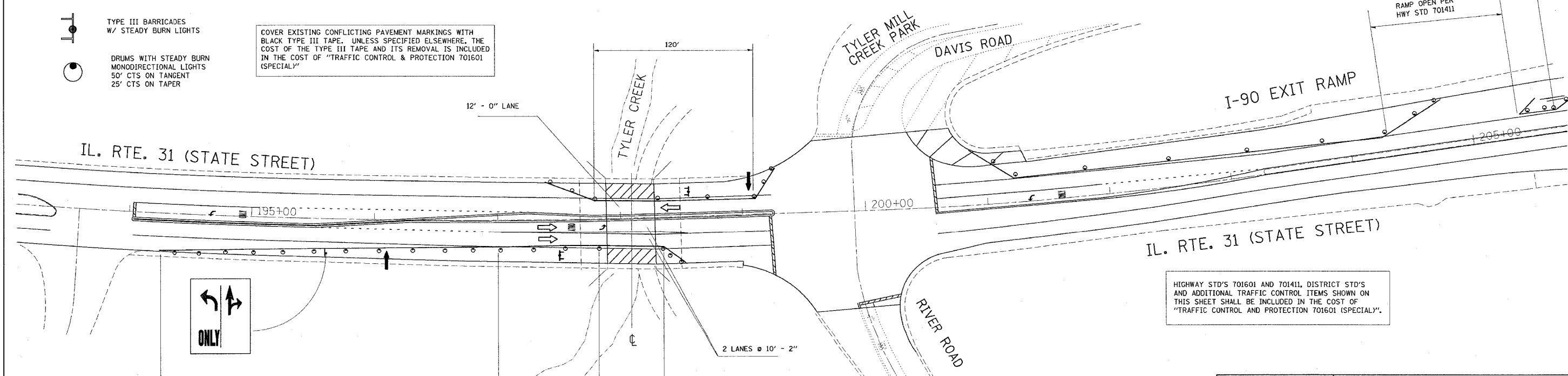

STAGE II CONSTRUCTION

HIGHWAY STD'S 701601 AND 701411, DISTRICT STD'S AND ADDITIONAL TRAFFIC CONTROL ITEMS SHOWN ON THIS SHEET SHALL BE INCLUDED IN THE COST OF "TRAFFIC CONTROL AND PROTECTION 701601 (SPECIAL)".

REVISIONS	
NAME	DATE

ILLINOIS DEPARTMENT OF TRANSPORTATION
 IL 31 OVER TYLER CREEK
 SN 045-0015
 TRAFFIC STAGING PLAN
 SCALE: VERT. 1"=50'
 HORIZ. 1"=50'
 DATE 4/19/2007
 DRAWN BY
 CHECKED BY

PLOT DATE = 4/19/2007
 PLOT SCALE = 1/8"=1'-0"
 PLOT USER = jrb
 PLOT USER = jrb

CONTRACT 600.64

P. & U. BYE	SECTION	COUNTY	TOTAL SHEETS	SHEET NO.
3887	*	KANE	43	22
STA.		TO STA.		
FED. ROAD DIST. NO. & Y.		ILLINOIS	FED. AID PROJECT	

* (E-1, P, G, H & R) RS-5

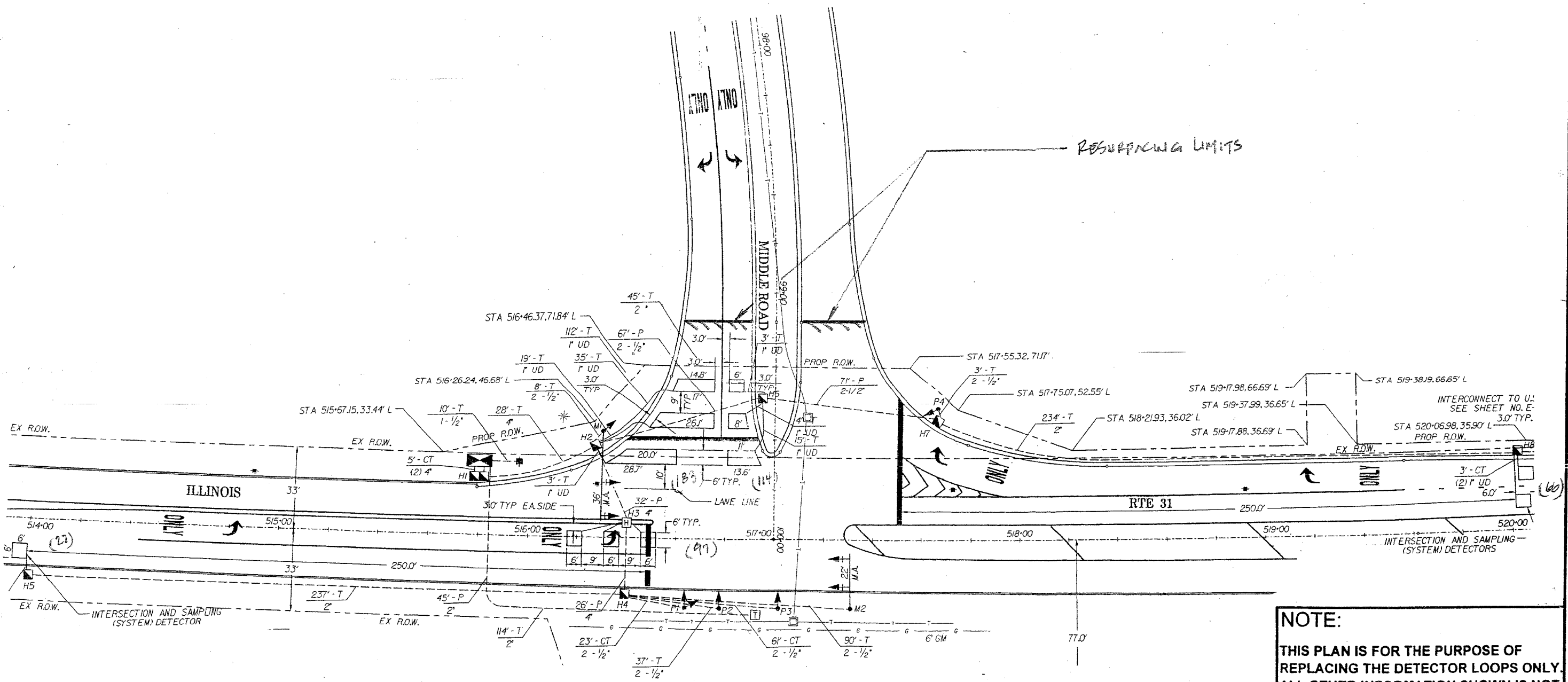
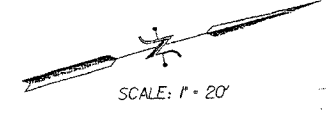

NOTE:
 THIS PLAN IS FOR THE PURPOSE OF REPLACING THE DETECTOR LOOPS ONLY. ALL OTHER INFORMATION SHOWN IS NOT RELATED AND WILL BE DISREGARDED.

REPLACE ALL DETECTOR LOOPS AS SHOWN
 (WITHIN THE RESURFACING LIMITS)

CODE NO.	QUANTITY	UNIT	ITEM
86600600	487	Foot	Detector Loop Replacement

REVISIONS	
NAME	DATE

ILLINOIS DEPARTMENT OF TRANSPORTATION
DETECTOR LOOP REPLACEMENT

SCALE: NONE
 DATE: MAR. 2007

DRAWN BY: JHE
 DESIGNED BY: JHE
 CHECKED BY: DAD

CONTRACT GDC6A

SECTION	COUNTY	TOTAL SHEETS	SHEET NO.
3887	ROUSE	43	23
STA.	TO STA.		FED. ROAD DIST. NO. 7
			ILLINOIS
		FED. AID PROJECT	

*(E-1, P, G, H & R) RS-5

LIMIT RESURFACING

CABLE PLAN

- VEHICLE DETECTOR, INDUCTION LOOP
- ⊙ DENOTES NUMBER OF CONDUCTORS (NEV) ALL CABLE NO. 12 EXCEPT AS INDICATED
- ⊙ INDICATES EXISTING CABLE
- MAGNETIC DETECTOR
- OPTICAL DETECTOR
- Ⓟ SIGNAL FACE WITH BACKPLATE 'P' INDICATES PROGRAMMED

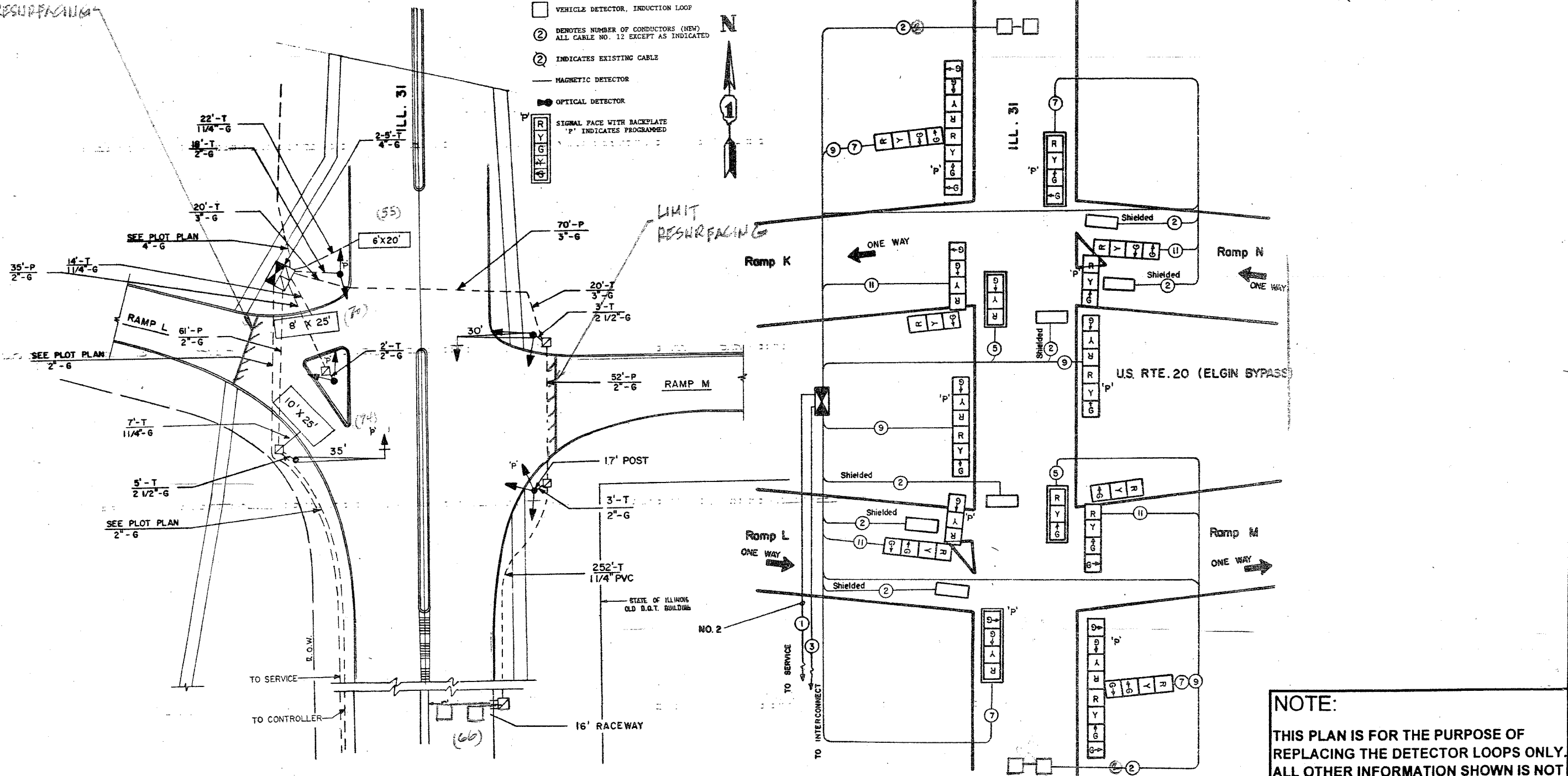

NOTE:
 THIS PLAN IS FOR THE PURPOSE OF REPLACING THE DETECTOR LOOPS ONLY. ALL OTHER INFORMATION SHOWN IS NOT RELATED AND WILL BE DISREGARDED.

REPLACE ALL DETECTOR LOOPS AS SHOWN

(WITHIN THE RESURFACING LIMITS)

CODE NO.	QUANTITY	UNIT	ITEM
86600600	265	Foot	Detector Loop Replacement

REVISIONS	
NAME	DATE

ILLINOIS DEPARTMENT OF TRANSPORTATION
DETECTOR LOOP REPLACEMENT
 ILL. RTE. 31 @ U.S. 20 (S. RAMPS)

SCALE: NONE
 DATE: MAR. 2007

DRAWN BY: JHE
 DESIGNED BY: JHE
 CHECKED BY: DAD.

CONTRACT 60064

SECTION	COUNTY	TOTAL SHEETS	SHEET NO.
3807 *	KANE	43	24
STA. TO STA.		FED. ROAD DIST. NO. 7 ILLINOIS	
		FED. AID PROJECT	

*(E-1, P, G, H & R) RS-5

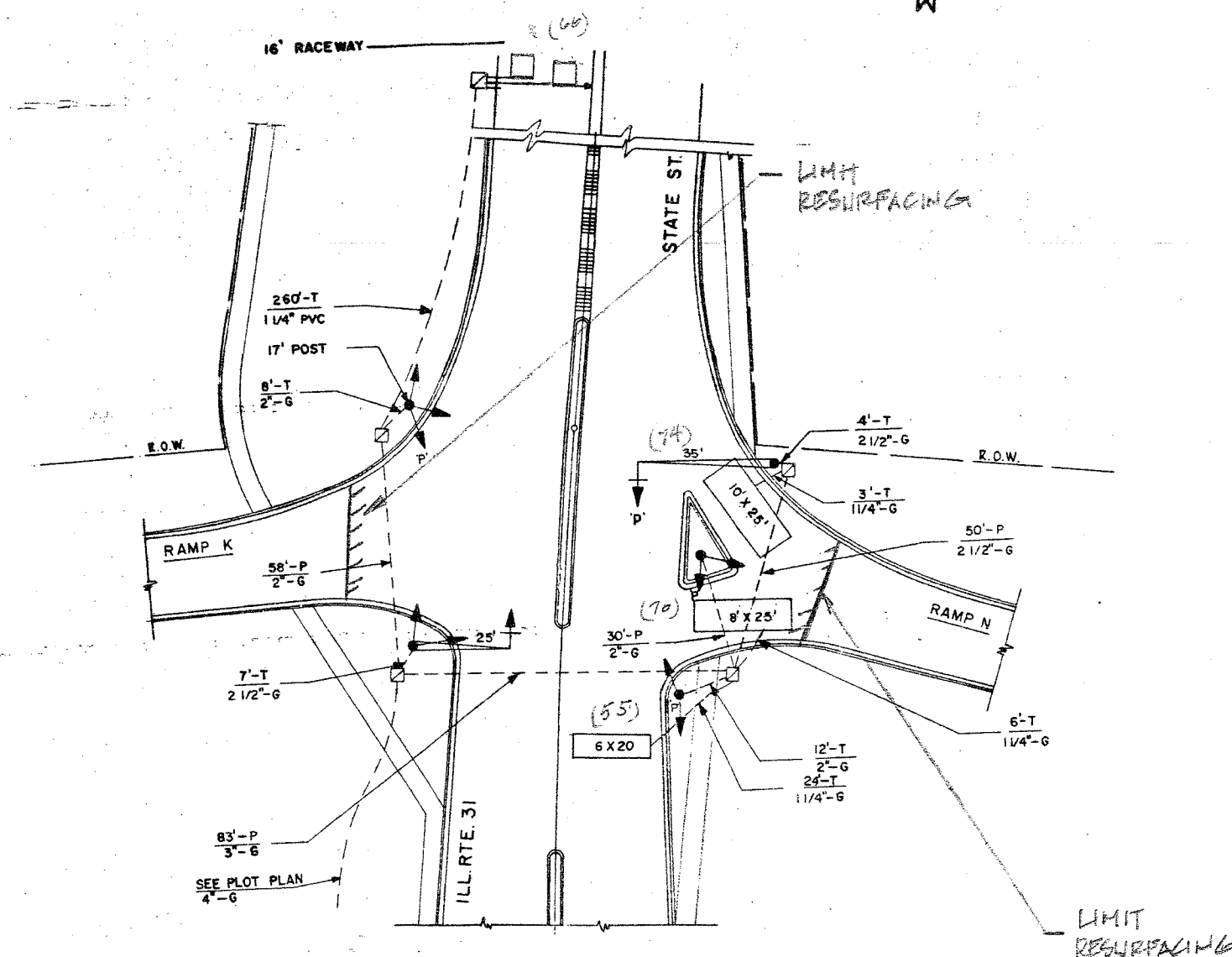

NOTE:
 THIS PLAN IS FOR THE PURPOSE OF REPLACING THE DETECTOR LOOPS ONLY. ALL OTHER INFORMATION SHOWN IS NOT RELATED AND WILL BE DISREGARDED.

REPLACE ALL DETECTOR LOOPS AS SHOWN
 (WITHIN THE RESURFACING LIMITS)

CODE NO.	QUANTITY	UNIT	ITEM
86600600	265	Foot	Detector Loop Replacement

REVISIONS	
NAME	DATE

ILLINOIS DEPARTMENT OF TRANSPORTATION
DETECTOR LOOP REPLACEMENT
 ILL. RTE. 31 @ U.S. 70 (N. RAMP)
 SCALE: NONE
 DATE: MAR. 2007
 DRAWN BY: JHE.
 DESIGNED BY: JHE.
 CHECKED BY: DAD.

AD 3887	SECTION *	COUNTY KANE	TOTAL SHEETS 43	SHEET NO. 25
STA.		TO STA.		
FED. ROAD DIST. NO. 1		ILLINOIS	FED. AID PROJECT	

* (E-1, P, G, H & R) RS-5

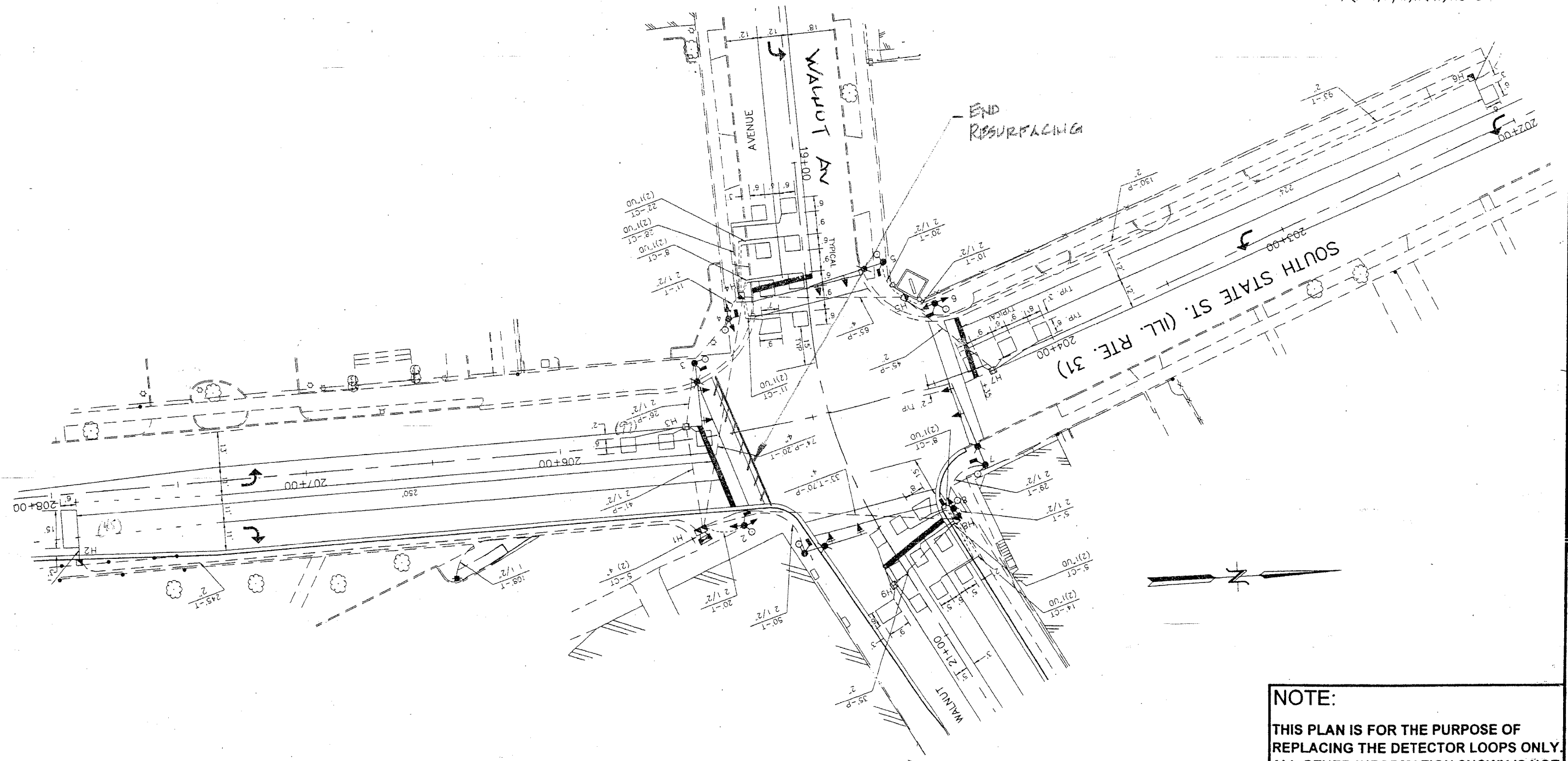

REPLACE ALL DETECTOR LOOPS AS SHOWN
(WITHIN THE RESURFACING LIMITS)

CODE NO.	QUANTITY	UNIT	ITEM
86600600	142	Foot	Detector Loop Replacement

REVISIONS	
NAME	DATE

NOTE:
THIS PLAN IS FOR THE PURPOSE OF REPLACING THE DETECTOR LOOPS ONLY. ALL OTHER INFORMATION SHOWN IS NOT RELATED AND WILL BE DISREGARDED.

ILLINOIS DEPARTMENT OF TRANSPORTATION
DETECTOR LOOP REPLACEMENT
ILL. RTE. 31 @ WALNUT AVE.
SCALE: NONE
DATE: MAR. 2001
DRAWN BY: JHE
DESIGNED BY: JHE
CHECKED BY: DAD

CONTRACT 60C64

PLAN SHEET NO.	SECTION	COUNTY	TOTAL SHEETS	SHEET NO.
3887	*	KANE	43	26
STA.	TO STA.		FED. AID PROJECT	

*(E-1, P, G, H & R) RS-5

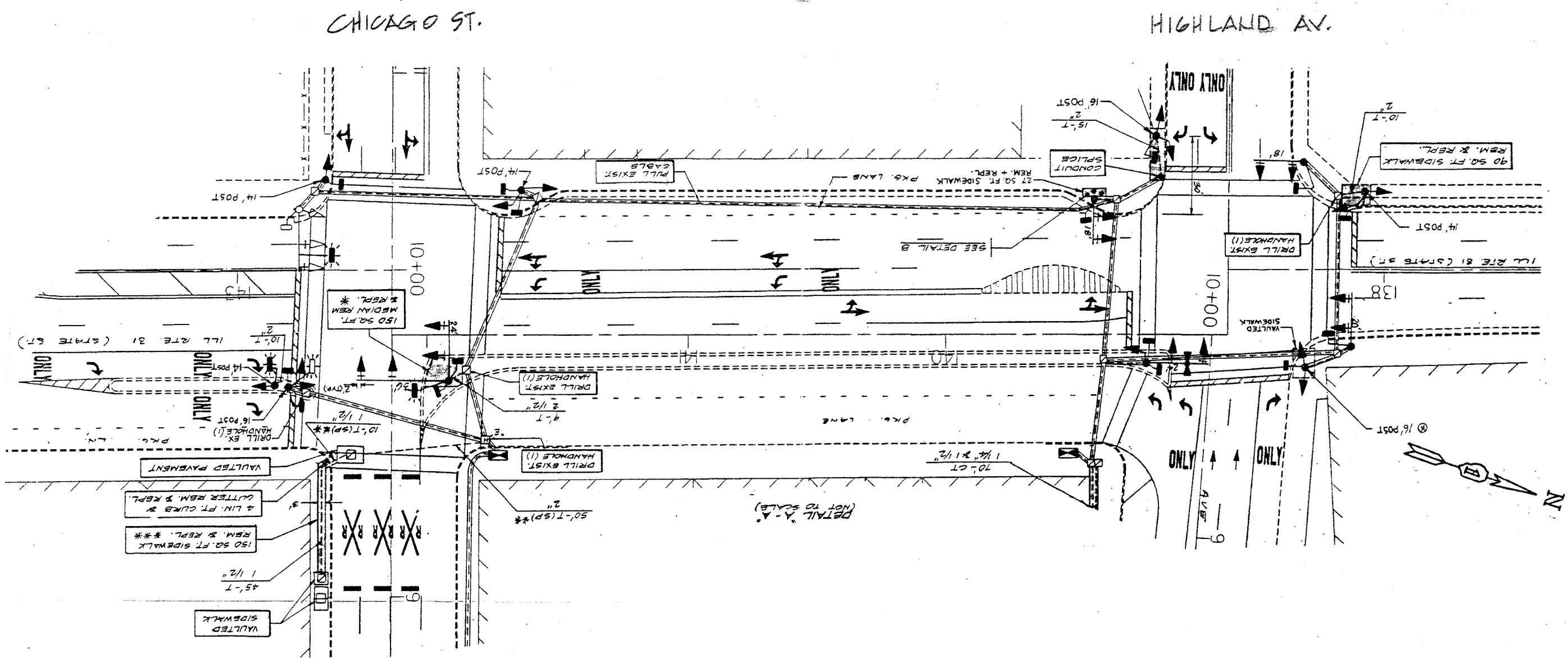

NOTE:
 THIS PLAN IS FOR THE PURPOSE OF REPLACING THE DETECTOR LOOPS ONLY. ALL OTHER INFORMATION SHOWN IS NOT RELATED AND WILL BE DISREGARDED.

REPLACE ALL DETECTOR LOOPS AS SHOWN
 (WITHIN THE RESURFACING LIMITS)

CODE NO.	QUANTITY	UNIT	ITEM
86600600	— 0 —	Foot	Detector Loop Replacement

REVISIONS	
NAME	DATE

ILLINOIS DEPARTMENT OF TRANSPORTATION
DETECTOR LOOP REPLACEMENT
 ILL. RTE. 31 @ HIGHLAND CHICAGO

SCALE NONE
 DATE MAR. 07

DRAWN BY JHE
 DESIGNED BY JHE
 CHECKED BY D.A.D.

CONTRACT 60C.64

F.U. SEC.	SECTION	COUNTY	TOTAL SHEETS	SHEET NO.
3887	*	KANE	43	27
STA.		TO STA.		
FED. ROAD DIST. NO. 7		ILLINOIS	FED. AID PROJECT	

*(E-1, P, G, H & R)RS-5

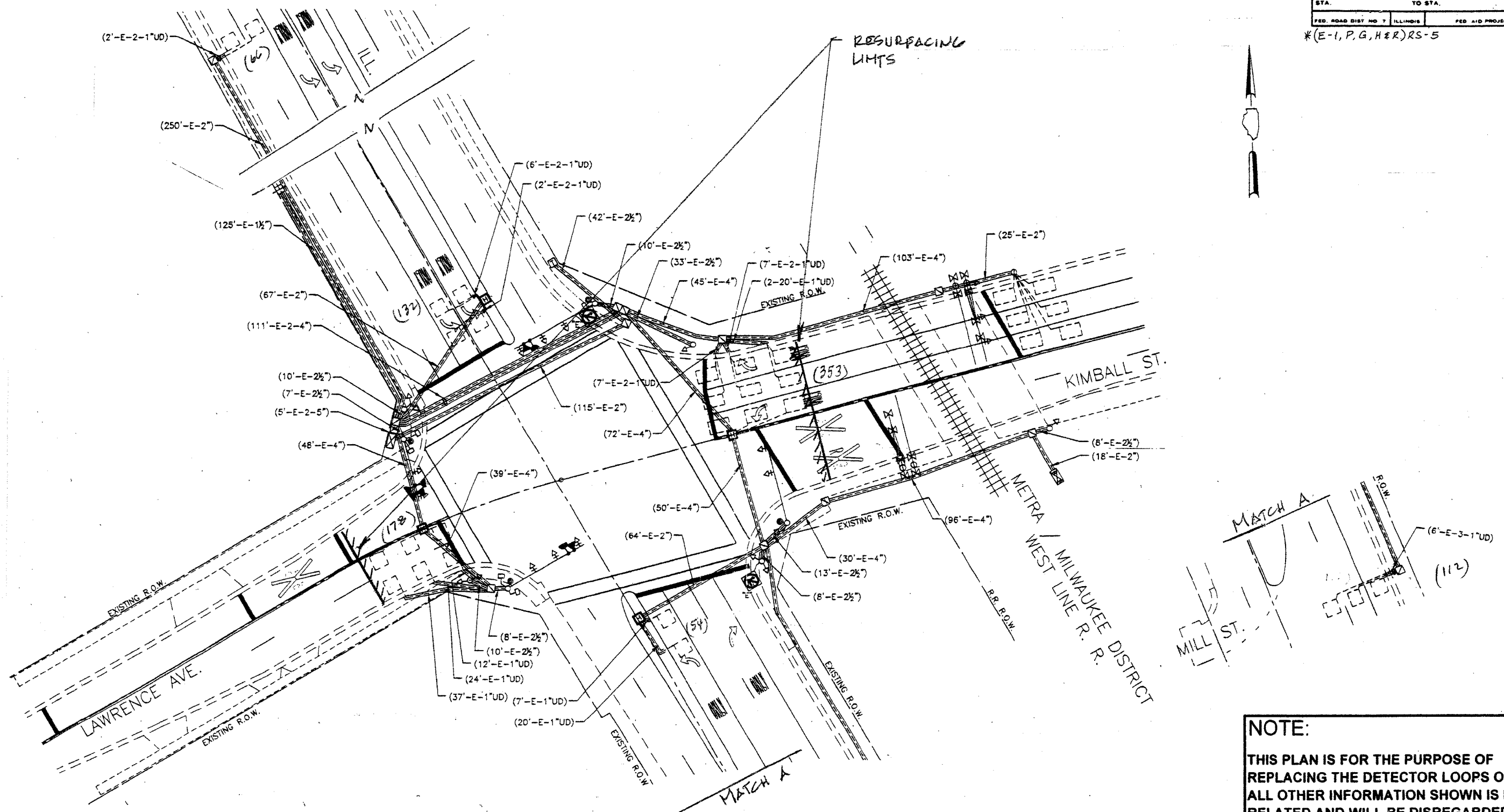

NOTE:
 THIS PLAN IS FOR THE PURPOSE OF REPLACING THE DETECTOR LOOPS ONLY. ALL OTHER INFORMATION SHOWN IS NOT RELATED AND WILL BE DISREGARDED.

REPLACE ALL DETECTOR LOOPS AS SHOWN
 (WITHIN THE RESURFACING LIMITS)

CODE NO.	QUANTITY	UNIT	ITEM
86600600	895	Foot	Detector Loop Replacement

REVISIONS	
NAME	DATE

ILLINOIS DEPARTMENT OF TRANSPORTATION
DETECTOR LOOP REPLACEMENT

SCALE: 1" = 20'
 DATE: _____

DRAWN BY: J.H.E.
 DESIGNED BY: J.H.E.
 CHECKED BY: D.A.D.

CONTRACT 60064

SECTION	COUNTY	TOTAL SHEETS	SHEET NO
* KANE	KANE	43	28
STA. TO STA.		FED. ROAD DIST NO 1 ILLINOIS	
		FED AID PROJECT	

*(E-1, P, G, H & R)RS-5

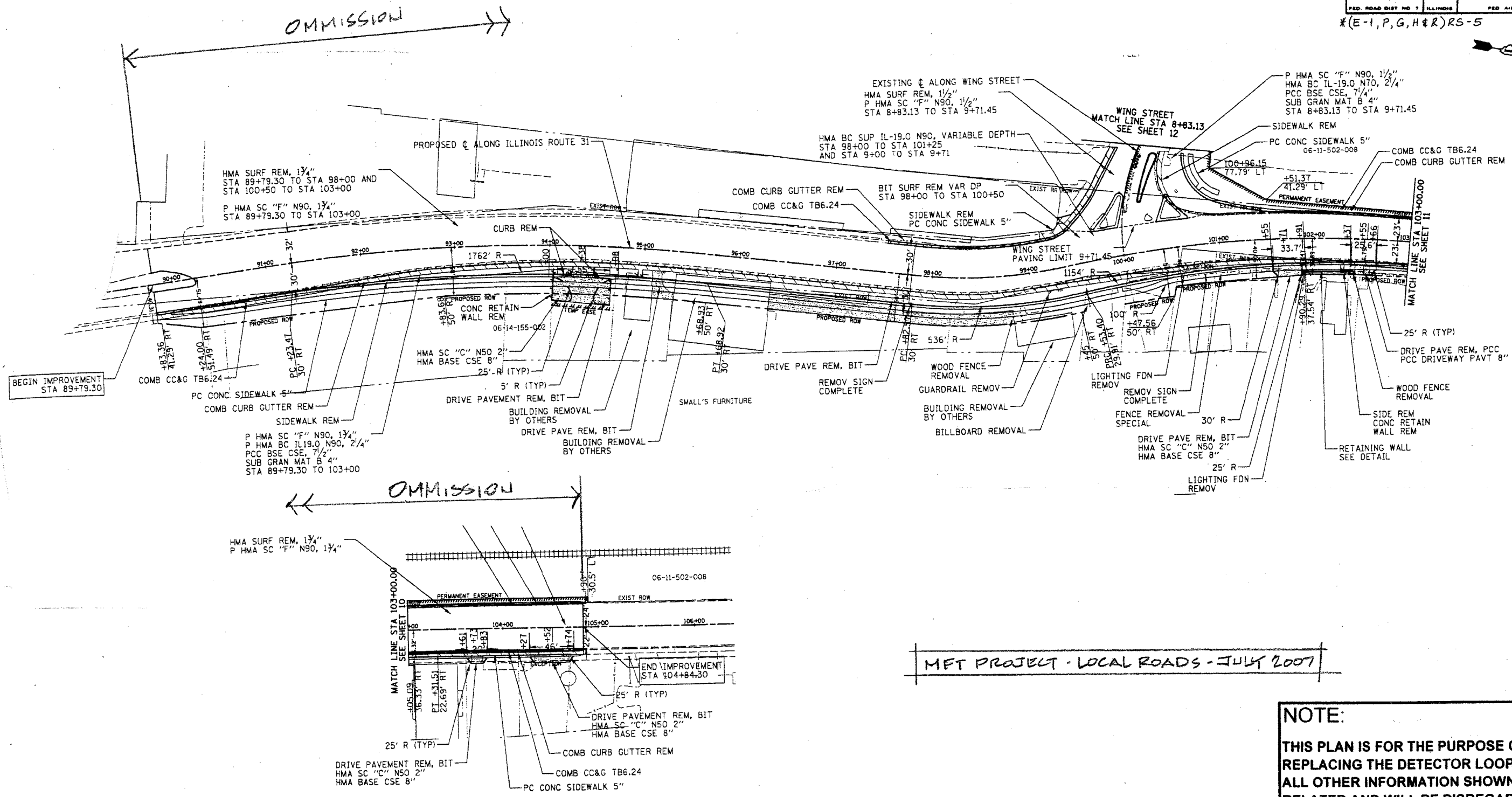

MFT PROJECT - LOCAL ROADS - JULY 2007

NOTE:
 THIS PLAN IS FOR THE PURPOSE OF REPLACING THE DETECTOR LOOPS ONLY. ALL OTHER INFORMATION SHOWN IS NOT RELATED AND WILL BE DISREGARDED.

REPLACE ALL DETECTOR LOOPS AS SHOWN
 (WITHIN THE RESURFACING LIMITS)

CODE NO.	QUANTITY	UNIT	ITEM
86600600	— 0 —	Foot	Detector Loop Replacement

REVISIONS	
NAME	DATE

ILLINOIS DEPARTMENT OF TRANSPORTATION
DETECTOR LOOP REPLACEMENT
 ILL. RTE. 31 @ WING ST. (OMMISSION)
 SCALE: None
 DATE: MAR. 07
 DRAWN BY: JHE
 DESIGNED BY: JHE
 CHECKED BY: D.A.D.

CONTRACT 60C6A

STATE	SECTION	COUNTY	TOTAL SHEETS	SHEET NO
3887	*	KANE	43	29
STA.	TO STA.			
FED. ROAD DIST NO. 7 ILLINOIS			FED. AID PROJECT	

*(E-1, P, G, H&R)RS-5

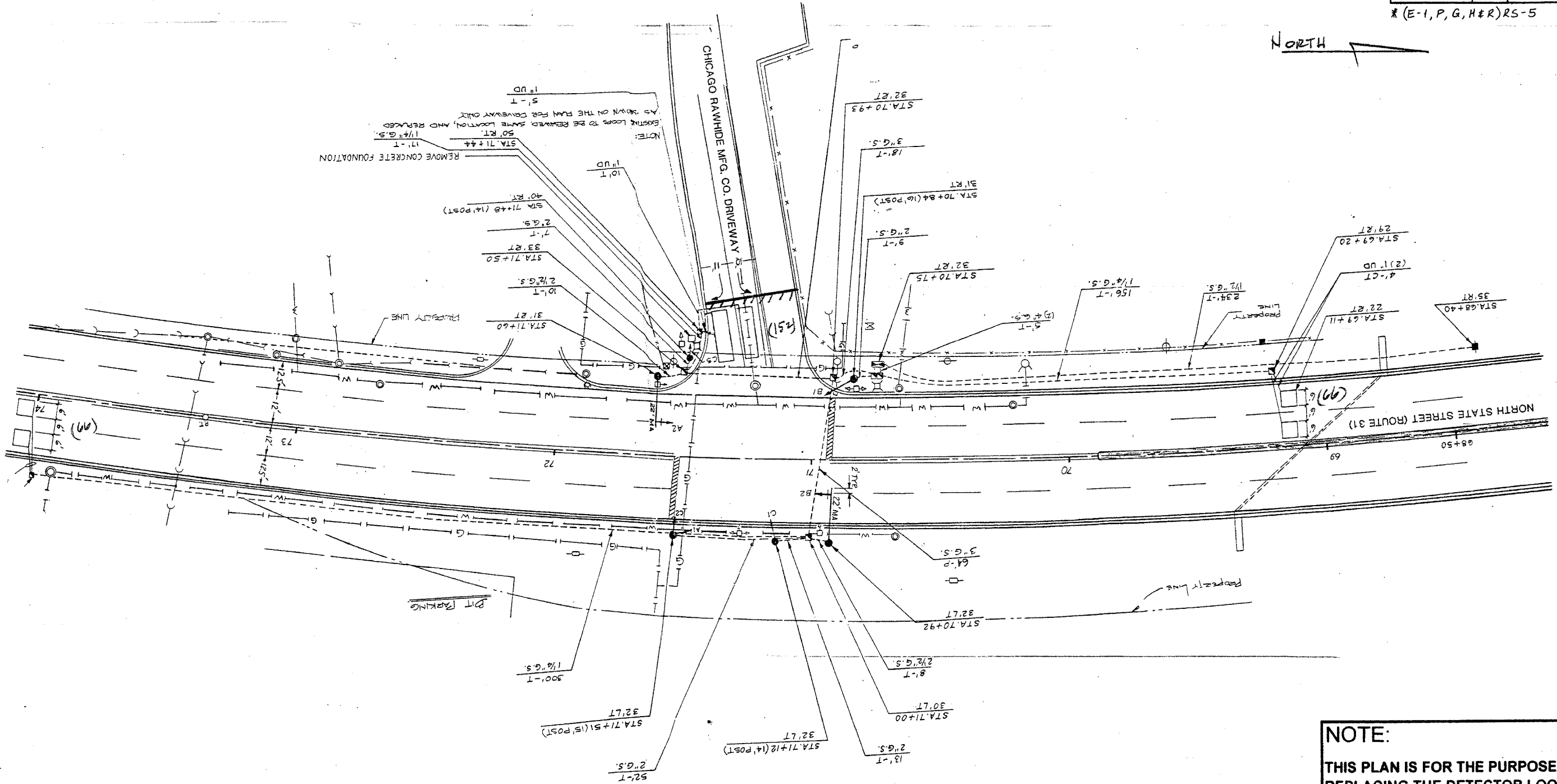
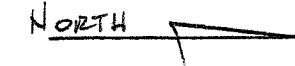

NOTE:
 THIS PLAN IS FOR THE PURPOSE OF REPLACING THE DETECTOR LOOPS ONLY. ALL OTHER INFORMATION SHOWN IS NOT RELATED AND WILL BE DISREGARDED.

REPLACE ALL DETECTOR LOOPS AS SHOWN
 (WITHIN THE RESURFACING LIMITS)

CODE NO.	QUANTITY	UNIT	ITEM
86600600	284	Foot	Detector Loop Replacement

REVISIONS	
NAME	DATE

ILLINOIS DEPARTMENT OF TRANSPORTATION
DETECTOR LOOP REPLACEMENT
 ILL. RTE. 31 @ CHICAGO RAWHIDE
 SCALE NONE
 DATE MARCH 07
 DRAWN BY JHE
 DESIGNED BY JHE
 CHECKED BY DAD

CONTRACT 60066

FILE NO.	SECTION	COUNTY	TOTAL SHEETS	SHEET NO.
3887	*	KANE	43	30
STA.		TO STA.		
FED. ROAD DIST NO 7		ILLINOIS	FED AID PROJECT	

*(E-1, P, G, H & R) RS-5

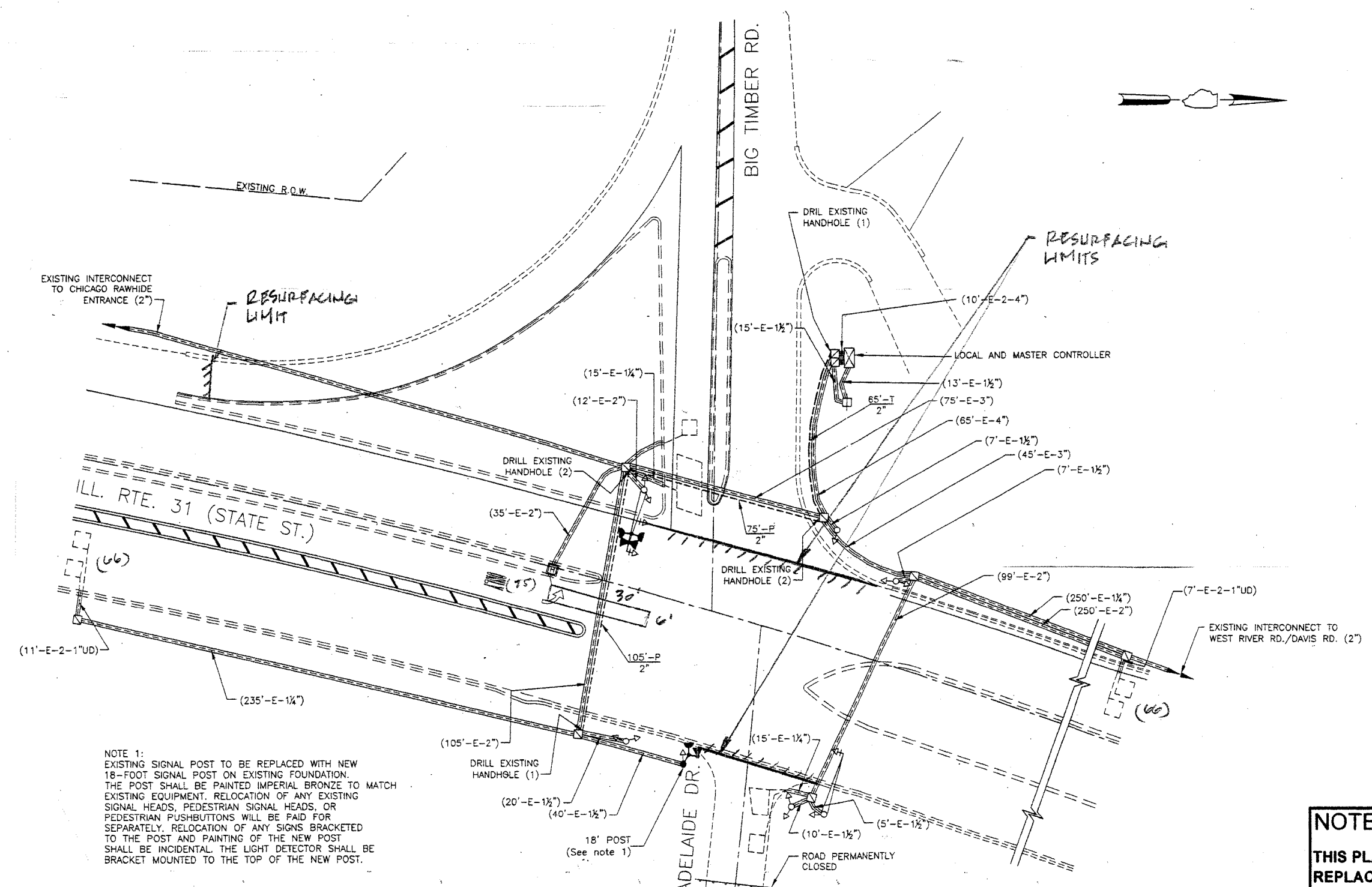

NOTE 1:
 EXISTING SIGNAL POST TO BE REPLACED WITH NEW 18-FOOT SIGNAL POST ON EXISTING FOUNDATION. THE POST SHALL BE PAINTED IMPERIAL BRONZE TO MATCH EXISTING EQUIPMENT. RELOCATION OF ANY EXISTING SIGNAL HEADS, PEDESTRIAN SIGNAL HEADS, OR PEDESTRIAN PUSHBUTTONS WILL BE PAID FOR SEPARATELY. RELOCATION OF ANY SIGNS BRACKETED TO THE POST AND PAINTING OF THE NEW POST SHALL BE INCIDENTAL. THE LIGHT DETECTOR SHALL BE BRACKET MOUNTED TO THE TOP OF THE NEW POST.

NOTE:
 THIS PLAN IS FOR THE PURPOSE OF REPLACING THE DETECTOR LOOPS ONLY. ALL OTHER INFORMATION SHOWN IS NOT RELATED AND WILL BE DISREGARDED.

REPLACE ALL DETECTOR LOOPS AS SHOWN
 (WITHIN THE RESURFACING LIMITS)

CODE NO.	QUANTITY	UNIT	ITEM
86600600	273	Foot	Detector Loop Replacement

REVISIONS	
NAME	DATE

ILLINOIS DEPARTMENT OF TRANSPORTATION
DETECTOR LOOP REPLACEMENT
 ILL. RTE. 31 @ BIG TIMBER RD.
 SCALE: NONE
 DATE: MAR. 2007
 DRAWN BY: JHE
 DESIGNED BY: JHE
 CHECKED BY: D.A.D.

CONTRACT 60264

SECTION	COUNTY	TOTAL SHEETS	SHEET NO
3087 *	KANE	43	31
STA. TO STA.		FED. ROAD DIST NO 1 ILLINOIS FED. AID PROJECT	

*(E-I, P, G, H & R)RS-5

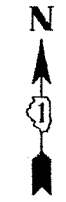
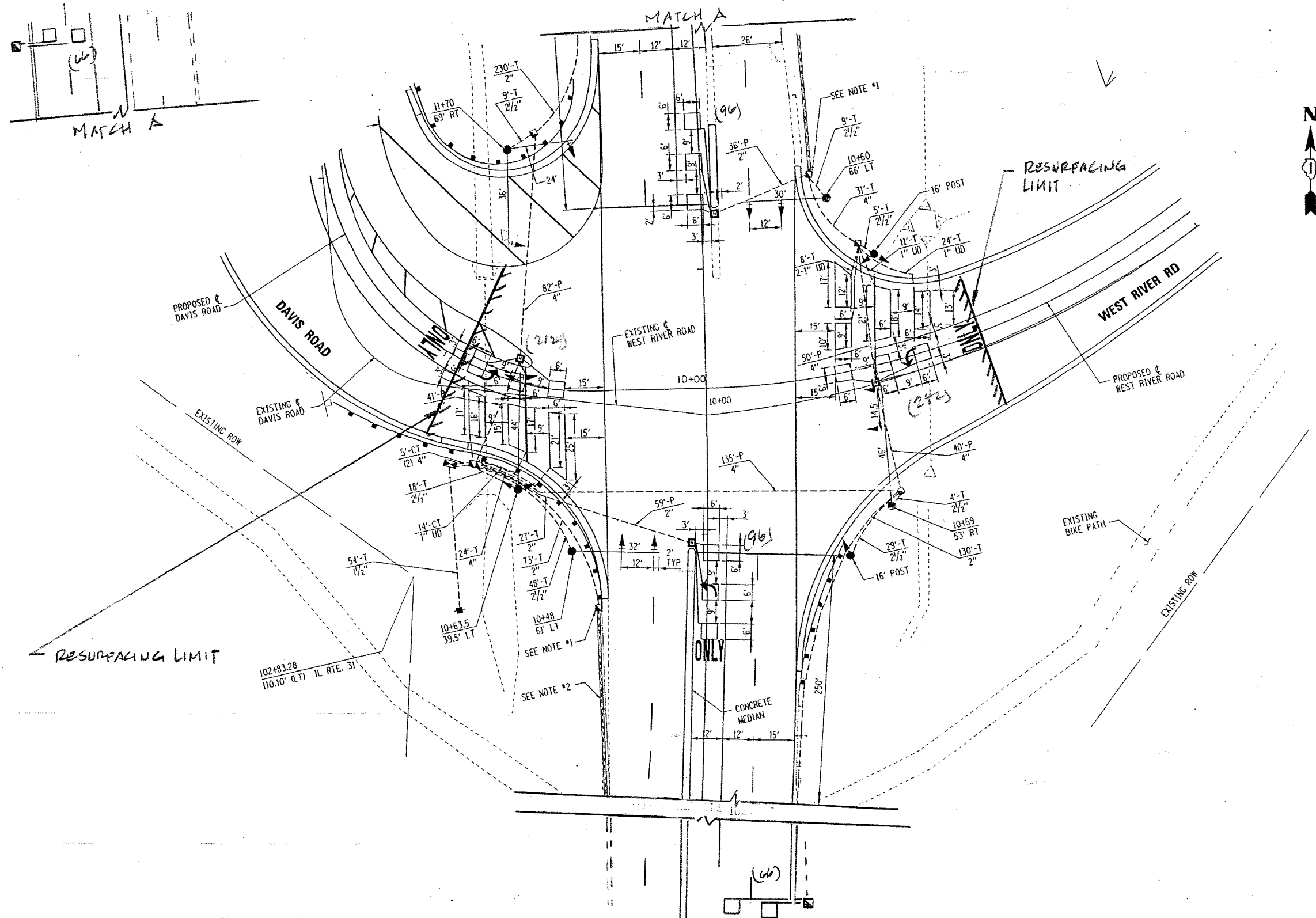

NOTE:
 THIS PLAN IS FOR THE PURPOSE OF REPLACING THE DETECTOR LOOPS ONLY. ALL OTHER INFORMATION SHOWN IS NOT RELATED AND WILL BE DISREGARDED.

REPLACE ALL DETECTOR LOOPS AS SHOWN
 (WITHIN THE RESURFACING LIMITS)

CODE NO.	QUANTITY	UNIT	ITEM
86600600	778	Foot	Detector Loop Replacement

REVISIONS	
NAME	DATE

ILLINOIS DEPARTMENT OF TRANSPORTATION
DETECTOR LOOP REPLACEMENT
 ILL. RTE. 31 @ W. RIVER RD.
 SCALE: NONE
 DATE: MAR. 07
 DRAWN BY: J.H.E.
 DESIGNED BY: J.H.E.
 CHECKED BY: D.A.D.

CONTRACT 60066

SECTION	COUNTY	TOTAL SHEETS	SHEET NO.
3607 *	KANE	43	32
STA. TO STA.			
FED. ROAD DIST. NO. 7 ILLINOIS		FED. AID PROJECT	

*(E-1, P, G, H & R) RS-5

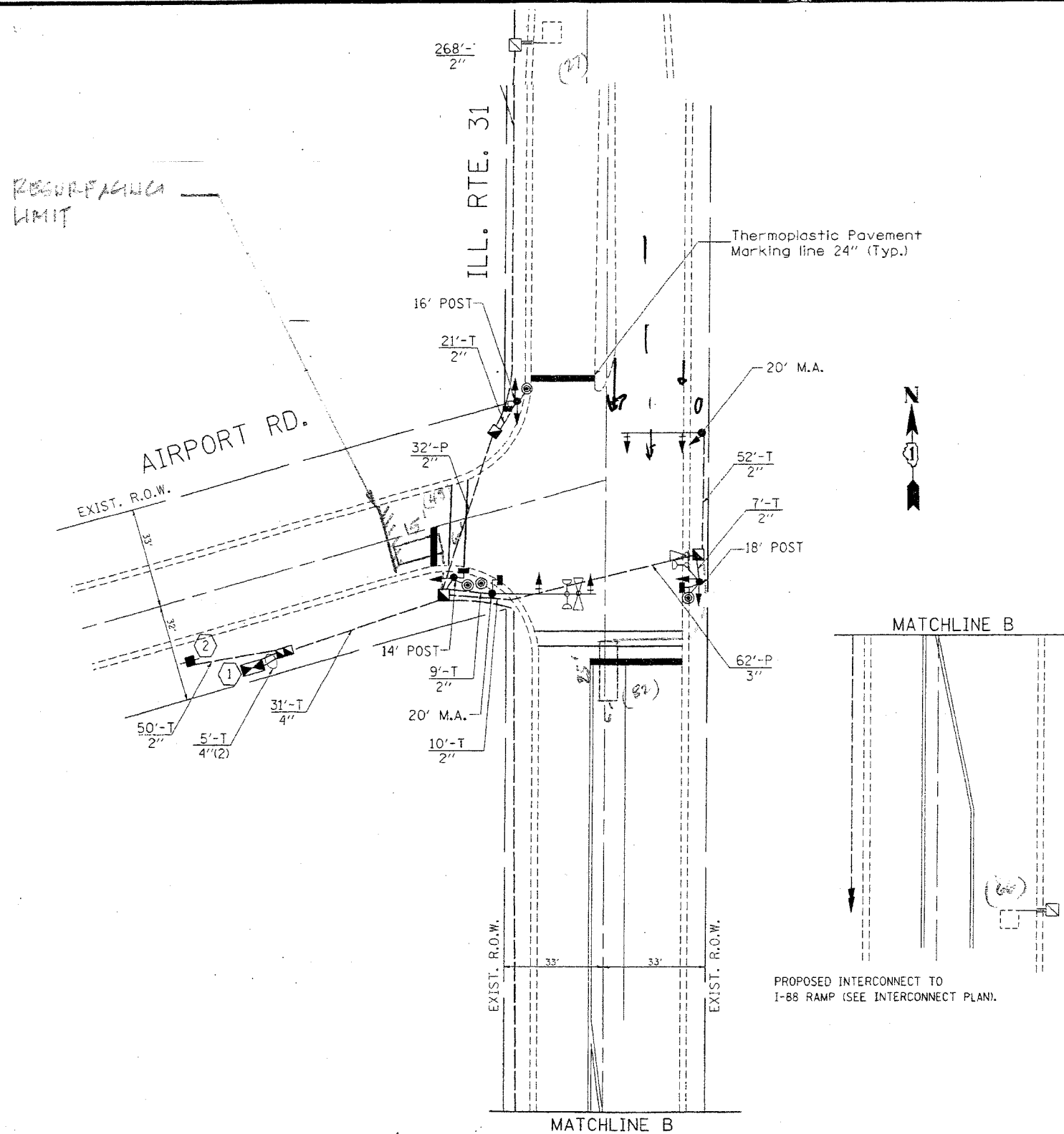

REPLACE ALL DETECTOR LOOPS AS SHOWN
(WITHIN THE RESURFACING LIMITS)

CODE NO.	QUANTITY	UNIT	ITEM
86600600	720	Foot	Detector Loop Replacement

REVISIONS	
NAME	DATE

NOTE:
THIS PLAN IS FOR THE PURPOSE OF REPLACING THE DETECTOR LOOPS ONLY. ALL OTHER INFORMATION SHOWN IS NOT RELATED AND WILL BE DISREGARDED.

ILLINOIS DEPARTMENT OF TRANSPORTATION
DETECTOR LOOP REPLACEMENT
ILL. RTE. 31 @ AIRPORT RD.
SCALE: *AS SHOWN*
DATE: *MARCH 07*
DRAWN BY: J.H.E.
DESIGNED BY: J.H.E.
CHECKED BY: D.A.D.

F.A.U. RTE.	SECTION	COUNTY	TOTAL SHEETS	SHEET NO.
3887	(E-1, P, G, H & R) RS-5	KANE	43	33
STA.		TO STA.		
FED. ROAD DIST. NO. 1		ILLINOIS	HIGHWAY PROJECT	

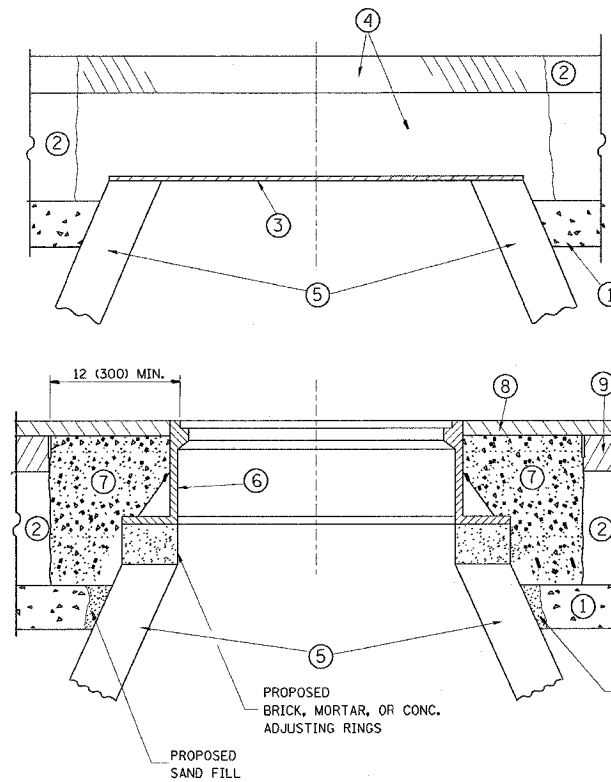

CONSTRUCTION PROCEDURES

STAGE 1 (BEFORE PAVEMENT MILLING)

- A) REMOVE A MINIMUM OF 12 (300) OF THE PAVEMENT FROM AROUND THE STRUCTURE.
- B) REMOVE THE EXISTING FRAME AND LID FROM THE STRUCTURE.
- C) COVER THE STRUCTURE OPENING WITH A 36 (900) DIAMETER METAL PLATE.
- D) BACKFILL WITH CRUSHED STONE AND A MINIMUM 1 1/2 (40) THICK HMA SURFACE MIX APPROVED BY THE ENGINEER.

STAGE 2 (AFTER PAVEMENT MILLING)

- A) REMOVE THE HMA SURFACE MIX AND CRUSHED STONE.
- B) INSTALL THE FRAME AND LID; ADJUST THE FRAME TO ITS FINAL SURFACE ELEVATION.
- C) THE SURROUNDING SPACE SHALL BE FILLED WITH CLASS SI CONCRETE, OR HMA SURFACE COURSE OR HMA BINDER COURSE TO THE ELEVATION OF THE SURFACE OF THE EXISTING BASE COURSE OR THE BINDER COURSE.

THE PROCEDURE EXPLAINED ABOVE SHALL CONFORM TO THE APPLICABLE PORTIONS OF SECTIONS 353, 406, 602, AND 603 OF THE STANDARD SPECIFICATIONS.

LEGEND

- ① SUB-BASE GRANULAR MATERIAL
- ② EXISTING PAVEMENT
- ③ 36 (900) DIAMETER METAL PLATE
- ④ PROPOSED CRUSHED STONE AND HMA SURFACE MIX
- ⑤ EXISTING STRUCTURE
- ⑥ FRAME AND LID (SEE NOTES)
- ⑦ CLASS SI CONCRETE, HMA SURFACE COURSE OR HMA BINDER COURSE
- ⑧ PROPOSED HMA SURFACE COURSE
- ⑨ PROPOSED HMA BINDER COURSE

LOCATION OF STRUCTURES:

THE CONTRACTOR WILL BE REQUIRED TO KEEP A RECORD OF THE LOCATIONS OF THE BURIED STRUCTURES ACCORDING TO THE STATION AND DISTANCE LEFT OR RIGHT OF THE CENTERLINE OF PAVEMENT. UPON COMPLETION OF THE WORK, THE CONTRACTOR WILL DELIVER THE RECORD TO THE ENGINEER.

BASIS OF PAYMENT: THIS WORK WILL BE PAID FOR AT THE CONTRACT UNIT PRICE PER EACH FOR "FRAMES AND LIDS TO BE ADJUSTED, SPECIAL"

NEW FRAMES AND LIDS, WHEN SPECIFIED, WILL BE PAID FOR SEPARATELY.

NOTES:

EXISTING BROKEN FRAMES AND LIDS SHALL BE REMOVED AND DISPOSED OF BY THE CONTRACTOR AND SHALL BE REPLACED AS DIRECTED BY THE ENGINEER. REPLACEMENT FRAMES AND LIDS WILL BE PAID FOR IN ACCORDANCE WITH ARTICLE 109.04 OF THE STANDARD SPECIFICATIONS UNLESS A SEPARATE PAY ITEM HAS BEEN PROVIDED.

IF THE EXISTING LIDS ARE OPEN, THE FRAME WILL BE ADJUSTED TO THE ELEVATION OF THE MILLED PAVEMENT SURFACE PRIOR TO THE MILLING OPERATION. THE FRAME WILL NOT BE REMOVED AND COVERED BY THE METAL PLATE.

CITY OF CHICAGO CASTINGS ARE THE PROPERTY OF THE CITY AND THE CONTRACTOR SHALL NOTIFY THE CITY FOR REMOVAL AND DISPOSITION OF THE CASTINGS.

THE METAL PLATE USED TO COVER THE STRUCTURE SHALL REMAIN THE PROPERTY OF THE CONTRACTOR.

WHEN STRUCTURES ARE TO BE ADJUSTED OR RECONSTRUCTED, THE LOWERING AND RAISING OF THE FRAMES AND LIDS WILL NOT BE PAID FOR SEPARATELY BUT WILL BE INCLUDED IN THE COST OF THE CORRESPONDING PAY ITEM.

DETAILS FOR FRAMES AND LIDS ADJUSTMENT WITH MILLING

ALL DIMENSIONS ARE IN INCHES (MILLIMETERS) UNLESS OTHERWISE SHOWN

REVISIONS	
NAME	DATE
R. SHAH	10/25/94
R. SHAH	01/30/95
R. SHAH	03/10/95
A. ABBAS	03/21/97
R. WIEDEMAN	05/14/04
R. BORO	01/01/07

ILLINOIS DEPARTMENT OF TRANSPORTATION
**DETAILS FOR
FRAMES AND LIDS ADJUSTMENT
WITH MILLING**

SCALE: VERT. NONE
HORIZ.

DRAWN BY

CHECKED BY

BD600-03 (BD-8)

F.A.U. RTE.	SECTION	COUNTY	TOTAL SHEETS	SHEET NO.
3887	(E-1, P, G, H, & R) RS-5	KANE	43	34
STA.		TO STA.		
FED. ROAD DIST. NO. 1	ILLINOIS	HIGHWAY PROJECT		

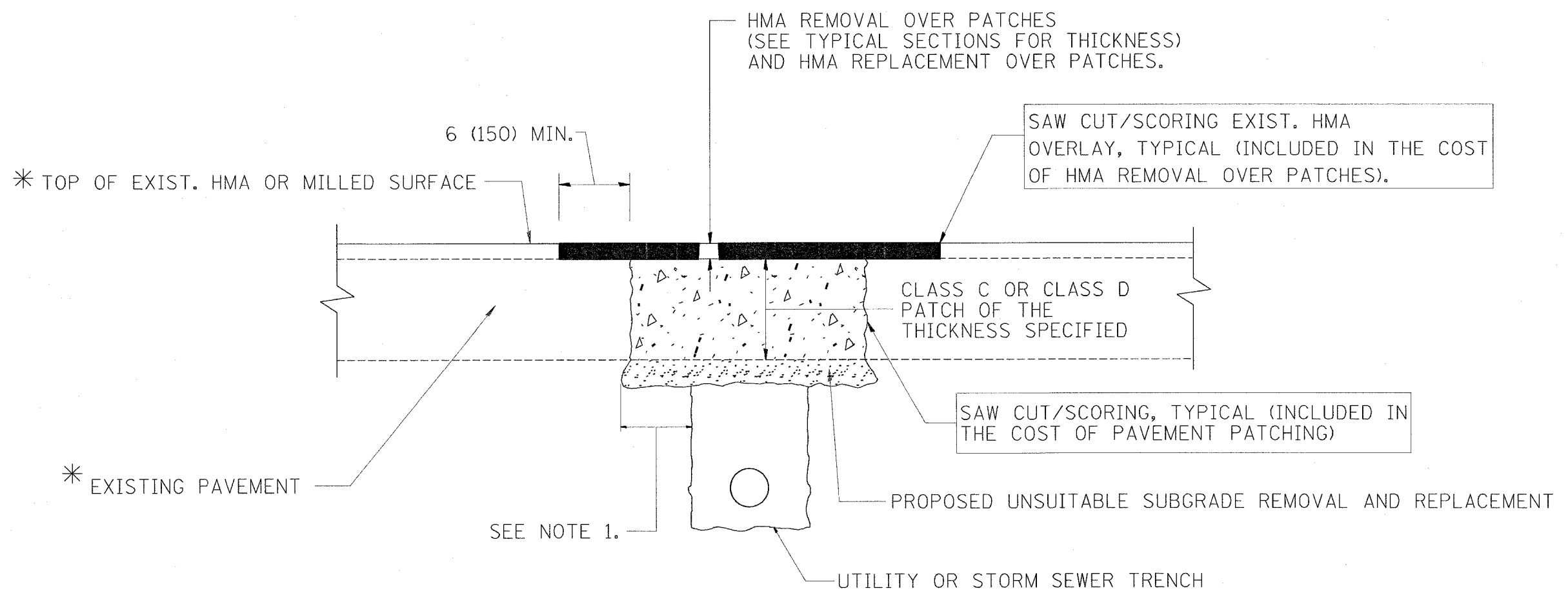

* SEE TYPICAL SECTIONS FOR THICKNESS AND MATERIALS

NOTES:

1. THE WIDTH OF THE FULL DEPTH PATCH OVER A TRENCH SHALL BE 12 (300) WIDER ON EACH SIDE OF THE TRENCH.
2. FOR METHOD OF MEASUREMENT AND BASIS OF PAYMENT, SEE RECURRING SPECIAL PROVISION "PATCHING WITH HOT-MIX ASPHALT OVERLAY REMOVAL".

SEQUENCE OF CONSTRUCTION

1. REMOVE THE EXISTING HMA MATERIAL OVER THE AREA TO BE PATCHED.
2. REMOVE AND REPLACE FULL DEPTH PATCHES
3. REPLACE HMA MATERIAL OVER THE AREA TO BE PATCHED.

ALL DIMENSIONS ARE IN INCHES (MILLIMETERS) UNLESS OTHERWISE SHOWN.

REVISIONS	
NAME	DATE
R. SHAH	10/25/94
R. SHAH	01/14/95
R. SHAH	03/23/99
R. SHAH	04/24/99
A. HOUSEH	03/15/96
A. ABBAS	03/21/97
A. ABBAS	01/20/98
ART ABBAS	04/27/98
R. BORO	01/01/07

ILLINOIS DEPARTMENT OF TRANSPORTATION

PAVEMENT PATCHING FOR HMA SURFACED PAVEMENT

SCALE: VERT. NONE
HORIZ.

DRAWN BY
CHECKED BY
BD400-04 (BD-22)

PLOT DATE = 4/17/2007
FILE NAME = S:\M\F\PLAN\PREP\SSOUND\1\Des.DW\cond standard\bd22.dgn
USER NAME = jtrant

F.A.U. RTE.	SECTION	COUNTY	TOTAL SHEETS	SHEET NO.
3887	(E-L, P, G, H & R) RS-5	KANE	43	35
STA.		TO STA.		
FED. ROAD DIST. NO. 1	ILLINOIS	HIGHWAY PROJECT		

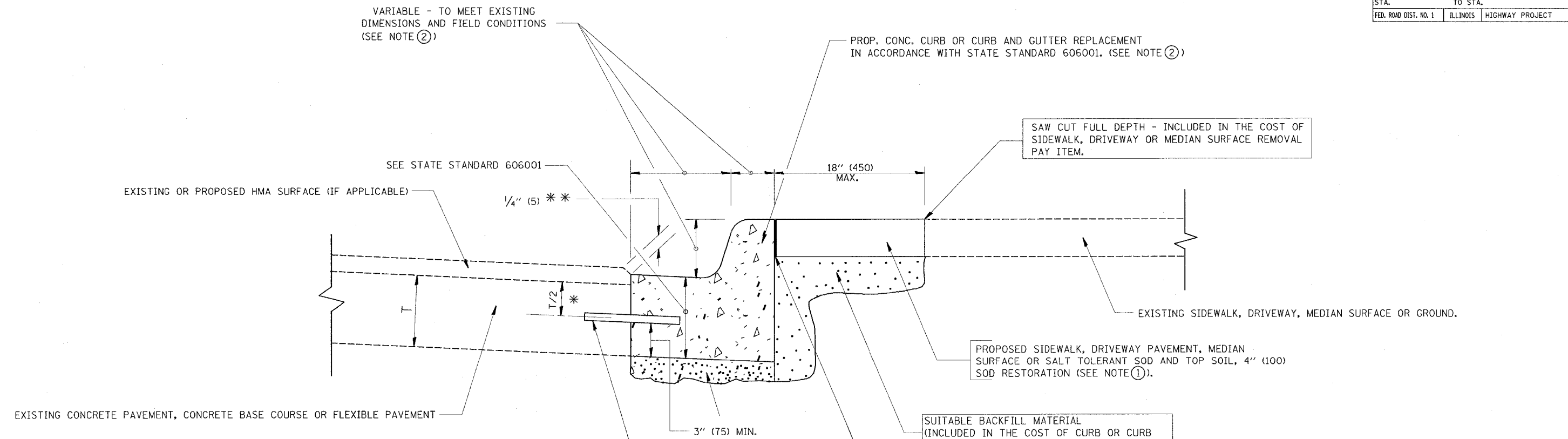

- * 3" (75) MINIMUM FROM TOP AND BOTTOM OF THE CONCRETE PAVEMENT OR BASE COURSE.
- ** IF THE FINAL SURFACE OF THE PAVEMENT IS CONCRETE, THE GUTTER IS TO BE FLUSH WITH THE PAVEMENT.

NOTE: ① SIDEWALK, DRIVEWAY PAVEMENT OR MEDIAN SURFACE SHALL BE SIMILAR TO THE MATERIAL BEING REMOVED AND WILL BE PAID FOR SEPARATELY.

SALT TOLERANT SOD AND TOP SOIL, 4" (100) RESTORATION WILL NOT BE PAID FOR SEPARATELY, BUT SHALL BE INCLUDED IN THE COST OF CURB OR CURB AND GUTTER REMOVAL AND REPLACEMENT.

- ② CURB OR CURB AND GUTTER REPLACEMENT SHALL MATCH THE SHAPE OF THE EXISTING CURB OR CURB AND GUTTER UNLESS OTHERWISE SPECIFIED.
- ③ FOR CURB OR CURB AND GUTTER REMOVAL AND REPLACEMENT ADJACENT TO FLEXIBLE PAVEMENT DELETE EPOXY COATED TIE BARS.
- ④ LONGITUDINAL BARS, IF ENCOUNTERED IN THE EXISTING CURB OR CURB AND GUTTER, ARE NOT TO BE REPLACED. CUTTING AND REMOVING LONGITUDINAL BARS SHALL BE INCLUDED IN THE COST OF CURB OR CURB AND GUTTER REMOVAL AND REPLACEMENT.
- ⑤ THE COST OF HMA SURFACE REMOVAL IN THE EXISTING GUTTER FLAG SHALL BE INCLUDED IN THE COST OF THE CURB AND GUTTER REMOVAL AND REPLACEMENT.
- ⑥ THE REMOVAL AND REPLACEMENT OF THE EXISTING CURB OR CURB AND GUTTER SHALL BE DONE IN ACCORDANCE WITH THE APPLICABLE PORTIONS OF SECTION 440 AND 606 OF THE STANDARD SPECIFICATIONS.
- ⑦ THE LOCATIONS OF REMOVAL AND REPLACEMENT OF EXISTING CURB OR CURB AND GUTTER SHALL BE DETERMINED BY THE RESIDENT ENGINEER AT THE TIME OF CONSTRUCTION.

UNSUITABLE SUB-BASE MATERIAL TO BE REMOVED, IF DIRECTED BY THE ENGINEER, SHALL BE REPLACED WITH EITHER SUB-BASE GRANULAR MATERIAL, TYPE B OR ADDITIONAL THICKNESS OF CONCRETE.

REMOVAL AND REPLACEMENT 4" (100) OR LESS IS INCLUDED IN THE COST OF CURB OR CURB AND GUTTER REMOVAL AND REPLACEMENT.

REMOVAL AND REPLACEMENT IN EXCESS OF 4" (100) WILL BE PAID FOR IN ACCORDANCE WITH ARTICLE 109.04 OF THE STANDARD SPECIFICATIONS.

PROPOSED #6 (20) EPOXY COATED TIE BARS 24" (600) LONG AT 24" (600) CENTERS WILL NOT BE PAID FOR SEPARATELY. DELETE EPOXY COATED TIE BARS IF EXISTING TIE BARS ARE USUABLE AS DETERMINED BY THE ENGINEER. (SEE NOTE 3).

BASIS OF PAYMENT:
THIS WORK WILL BE PAID FOR AT THE CONTRACT UNIT PRICE PER FOOT (METER) FOR "CURB REMOVAL AND REPLACEMENT" OR "COMBINATION CONCRETE CURB AND GUTTER REMOVAL AND REPLACEMENT".

ALL DIMENSIONS ARE IN INCHES (MILLIMETERS) UNLESS OTHERWISE SHOWN.

REVISIONS	
NAME	DATE
A. HOUSEH	03/11/94
R. SHAH	02/24/95
R. SHAH	03/02/95
R. SHAH	08/19/96
R. SHAH	09/12/96
R. SHAH	09/19/96
R. SHAH	10/03/96
A. ABBAS	03/21/97
M. GOMEZ	01/22/01
R. BORO	01/01/07

ILLINOIS DEPARTMENT OF TRANSPORTATION
CURB OR CURB AND GUTTER REMOVAL AND REPLACEMENT

SCALE: VERT. NONE
HORIZ.
DRAWN BY
CHECKED BY
BD600-06 (BD-24)

CURB OR CURB AND GUTTER REMOVAL AND REPLACEMENT

PLOT DATE = 4/18/2007
 FILE NAME = S:\MVP\PLANS\REFS\SQUAD_1\Drawn\cadd standards\bd24.dgn
 USER NAME = P. BORO

F.A.U. RTE.	SECTION	COUNTY	TOTAL SHEETS	SHEET NO.
3887	(E-1, P, G, H, & R) RS-5	KANE	43	36
STA.	TO STA.			
FED. ROAD DIST. NO. 1	ILLINOIS	HIGHWAY PROJECT		

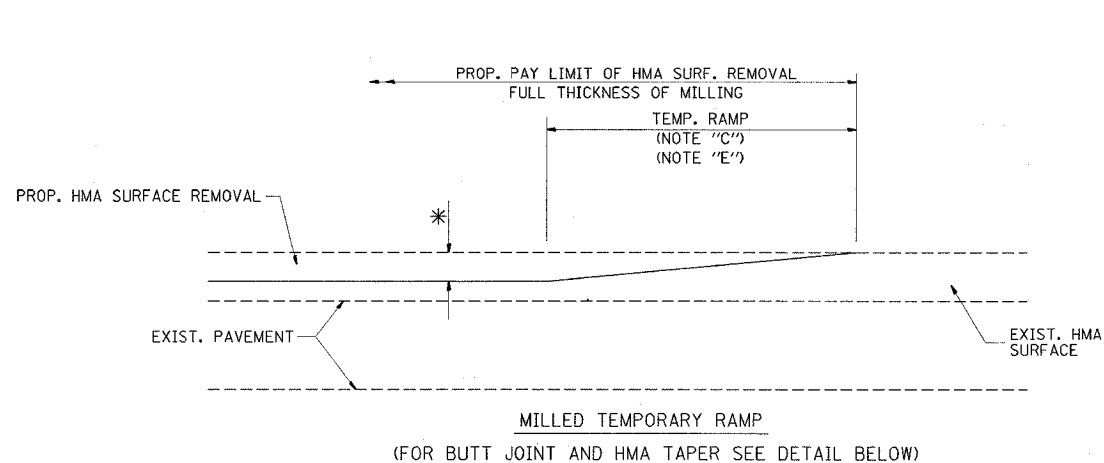

OPTION 1

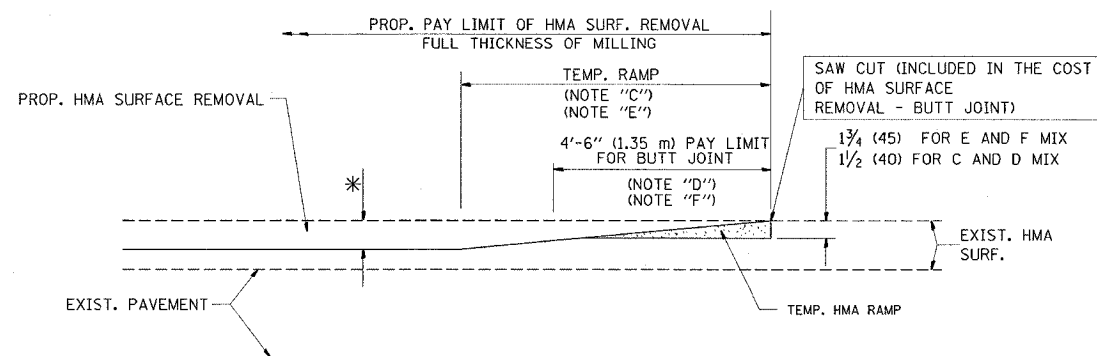

HMA CONSTRUCTED TEMPORARY RAMP
(FOR BUTT JOINT AND HMA TAPER SEE DETAIL BELOW)

OPTION 2
TYPICAL TEMPORARY RAMP

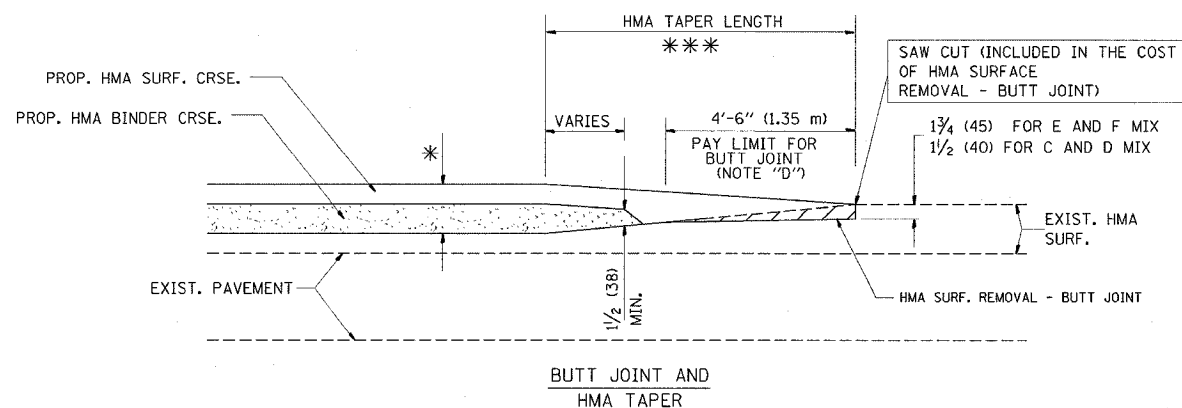

TYPICAL BUTT JOINT AND HMA TAPER
FOR MILLING AND RESURFACING

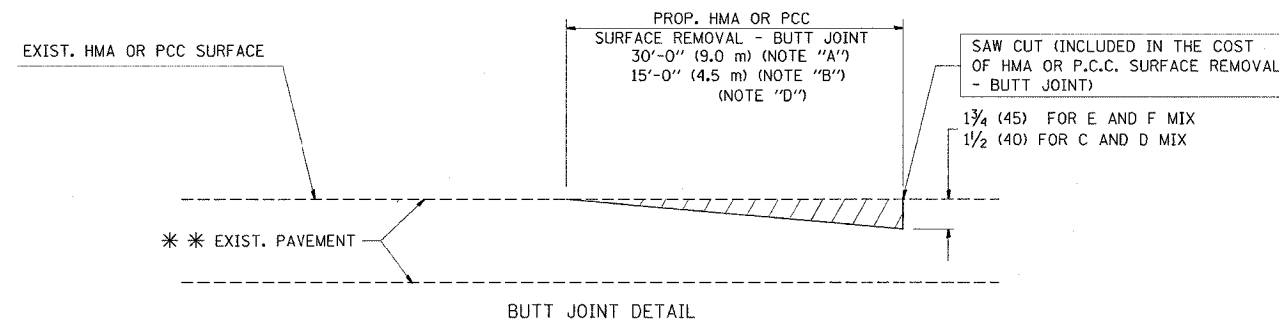

BUTT JOINT DETAIL

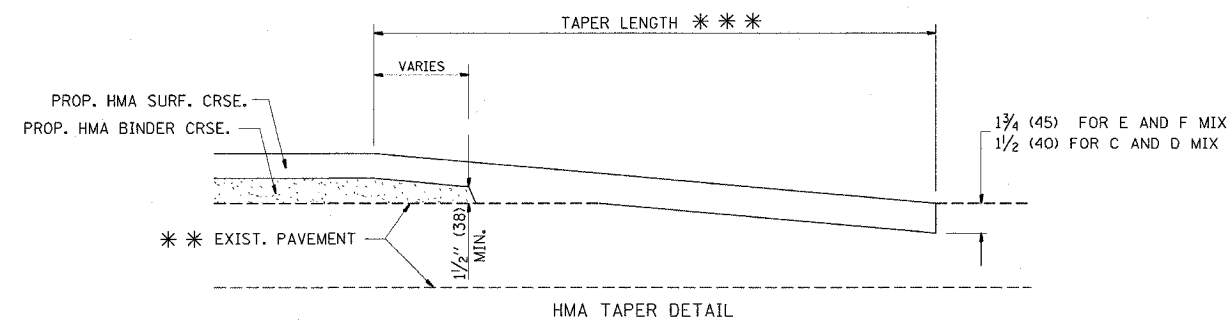

HMA TAPER DETAIL

TYPICAL BUTT JOINT AND HMA TAPER
FOR RESURFACING ONLY

*** PC CONCRETE, HMA OR HMA RESURFACED PAVEMENT.

NOTES

- A: MAINLINE ROADWAYS AND MAJOR SIDE ROADS.
 - B: MINOR SIDE ROADS.
 - C: THE TEMP. RAMP SHALL BE CONSTRUCTED IMMEDIATELY UPON REMOVAL OF THE EXISTING HMA SURFACE.
 - D: THE BUTT JOINT SHALL BE CONSTRUCTED IMMEDIATELY PRIOR TO PLACING THE PROPOSED HMA COURSES.
 - E: TAPER THE TEMP. RAMP AT A RATE OF 3'-0" (900 mm) PER 1 INCH (25 mm) OF MILLING THICKNESS.
 - F: INSTALLATION AND REMOVAL OF THE 4'-6" (1.35 m) TEMP. RAMP IS INCLUDED IN COST OF HMA SURFACE REMOVAL - BUTT JOINT
 - G: SEE ARTICLE 406.08 AND 406.14 OF THE STANDARD SPECIFICATIONS FOR "HMA AND/OR PCC SURFACE REMOVAL, BUTT JOINT".
- * SEE TYPICAL SECTIONS FOR MILLING THICKNESS.
- *** 20'-0" (6.1 m) PER 1 (25) RESURFACING (NOTE "A")
10'-0" (3.0 m) PER 1 (25) RESURFACING (NOTE "B")

ALL DIMENSIONS ARE IN INCHES (MILLIMETERS) UNLESS OTHERWISE SHOWN.

BASIS OF PAYMENT:

THE BUTT JOINT WILL BE PAID FOR AT THE CONTRACT UNIT PRICE PER SQUARE YARD (SQUARE METER) FOR "HOT-MIX ASPHALT SURFACE REMOVAL - BUTT JOINT" OR FOR "PORTLAND CEMENT CONCRETE SURFACE REMOVAL - BUTT JOINT".

REVISIONS	
NAME	DATE
M. DE YONG	6-13-90
M. DE YONG	7-3-90
M. DE YONG	3-27-92
R. SHAH	09/09/94
R. SHAH	10/25/94
A. ABBAS	03/21/97
M. GOMEZ	04/06/01
R. BORO	01/01/07

ILLINOIS DEPARTMENT OF TRANSPORTATION

BUTT JOINT AND
HMA TAPER
DETAILS

SCALE: VERT. NONE
HORIZ.

DRAWN BY
CHECKED BY

BD400-05 (VI-BD32)

F.A.U. RTE.	SECTION	COUNTY	TOTAL SHEETS	SHEET NO.
3887	(E-1, P, G, H, & R) RS-5	KANE	43	37
STA.		TO STA.		
FED. ROAD DIST. NO. 1	ILLINOIS	HIGHWAY PROJECT		

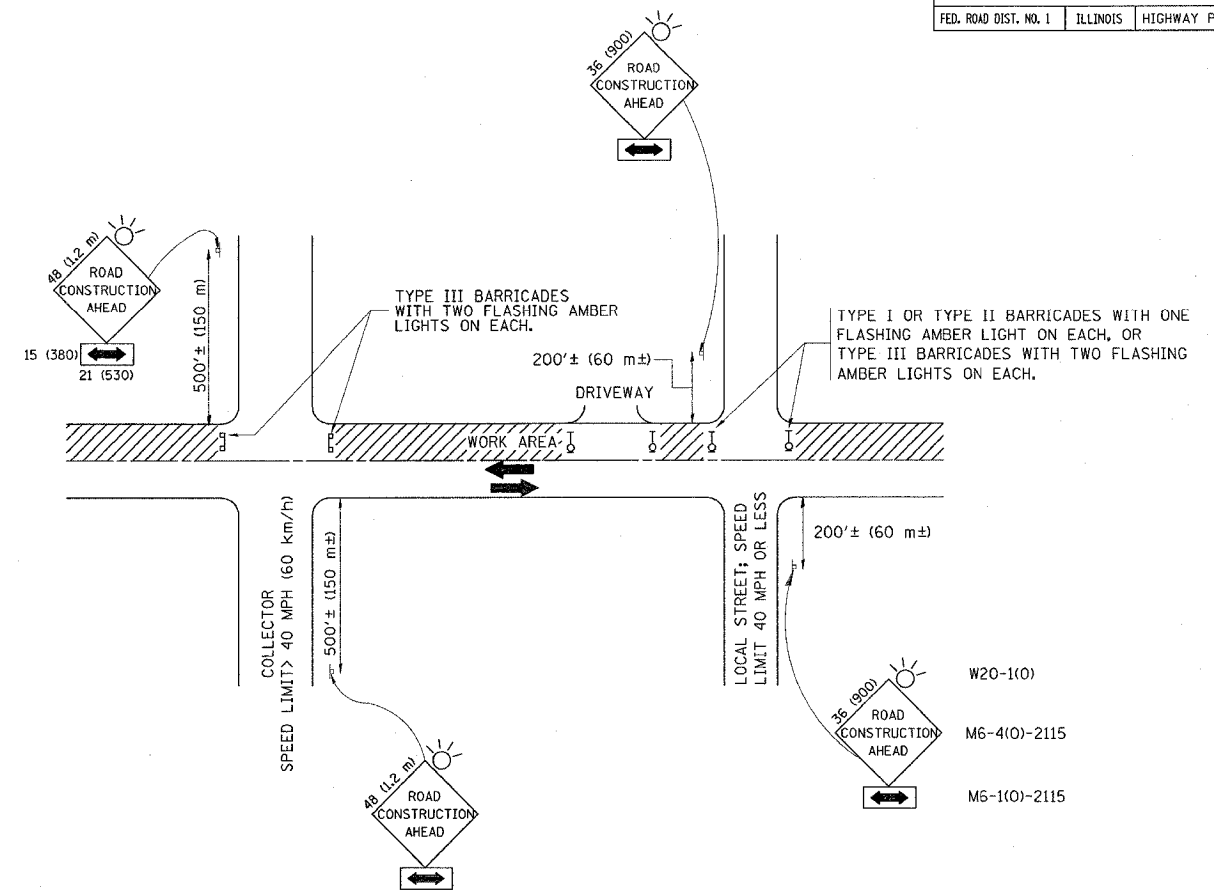

TRAFFIC CONTROL AND PROTECTION FOR SIDE ROADS, INTERSECTIONS, AND DRIVEWAYS

NOTES:

A. FOR NO LANE RESTRICTION ON THE SIDE ROAD OR DRIVEWAYS

- SIDE ROAD WITH A SPEED LIMIT OF 40 MPH (60 km/h) OR LESS AS SHOWN ON THE DRAWING AND AS DIRECTED BY THE ENGINEER:
 - ONE ROAD CONSTRUCTION AHEAD SIGN 36 x 36 (900x900) WITH A FLASHER AND FLAG MOUNTED ON IT APPROXIMATELY 200' (60 m) IN ADVANCE OF THE MAIN ROUTE.
 - THE CLOSED PORTION OF THE MAIN ROUTE SHALL BE PROTECTED BY BLOCKING WITH TYPE I, TYPE II OR TYPE III BARRICADES, 1/3 OF THE CROSS SECTION OF THE CLOSED PORTION.
- SIDE ROAD WITH A SPEED LIMIT GREATER THAN 40 MPH (60 km/h) AS SHOWN ON THE DRAWING AND AS DIRECTED BY THE ENGINEER:
 - ONE ROAD CONSTRUCTION AHEAD SIGN 48 x 48 (1.2 m x 1.2 m) WITH A FLASHER MOUNTED ON IT APPROXIMATELY 500' (150 m) IN ADVANCE OF THE MAIN ROUTE.
 - THE CLOSED PORTION OF THE MAIN ROUTE SHALL BE PROTECTED BY BLOCKING WITH TYPE III BARRICADES, 1/2 OF THE CROSS SECTION OF THE CLOSED PORTION.
- WHEN THE SIDE ROAD LIES BETWEEN THE BEGINNING OF THE MAINLINE SIGNING AND THE WORK ZONE, A SINGLE HEADED ARROW (M6-1) SHALL BE USED IN LIEU OF THE DOUBLE HEADED ARROW (M6-4).

B. FOR A LANE CLOSURE ON A SIDE ROAD OR DRIVEWAY:

- USE APPLICABLE PORTIONS OF THE TYPICAL APPLICATION OF TRAFFIC CONTROL DEVICES (STD. 701501, STD. 701606 OR THE APPROPRIATE STANDARD). THE SPACING OF SIGNS AND BARRICADES SHALL BE ADJUSTED FOR FIELD CONDITIONS AS DIRECTED BY THE ENGINEER. THE DIRECTIONAL ARROW SHALL BE COVERED OR REMOVED WHEN NO LONGER CONSISTENT WITH THE SIDE ROAD LANE CLOSURE.
- ADVANCE WARNING SIGNS ARE TO BE OMITTED ON DRIVEWAY UNLESS OTHERWISE NOTED.
 - THE TRAFFIC CONTROL AND PROTECTION FOR SIDE ROADS, INTERSECTIONS, AND DRIVEWAYS SHALL BE INCIDENTAL TO THE COST OF SPECIFIED TRAFFIC CONTROL STANDARDS OR ITEMS.

All dimensions are in millimeters (Inches) unless otherwise shown.

REVISIONS	
NAME	DATE
LHA	6/89
T. RAMMACHER	09/08/94
J. OBERLE	10/18/95
A. HOUSEH	03/06/96
A. HOUSEH	10/15/96
T. RAMMACHER	01/06/00

ILLINOIS DEPARTMENT OF TRANSPORTATION
 TRAFFIC CONTROL AND PROTECTION
 FOR
 SIDE ROADS, INTERSECTIONS, AND
 DRIVEWAYS

SCALE: NONE

DRAWN BY
 CHECKED BY
 TC-10

PLOT DATE = 4/17/2007
 FILE NAME = S:\MVP\PLANS\REP\SQUAD\1\Draw\DW\Acadd_standards\tbl.dgn
 USER NAME = jrb
 USER ID = 1000000000



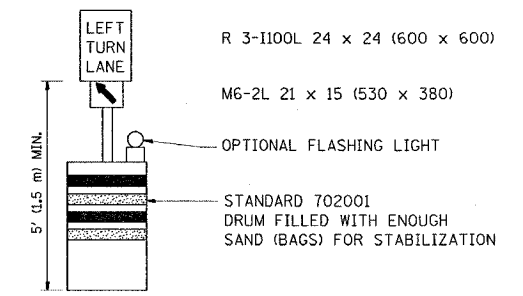
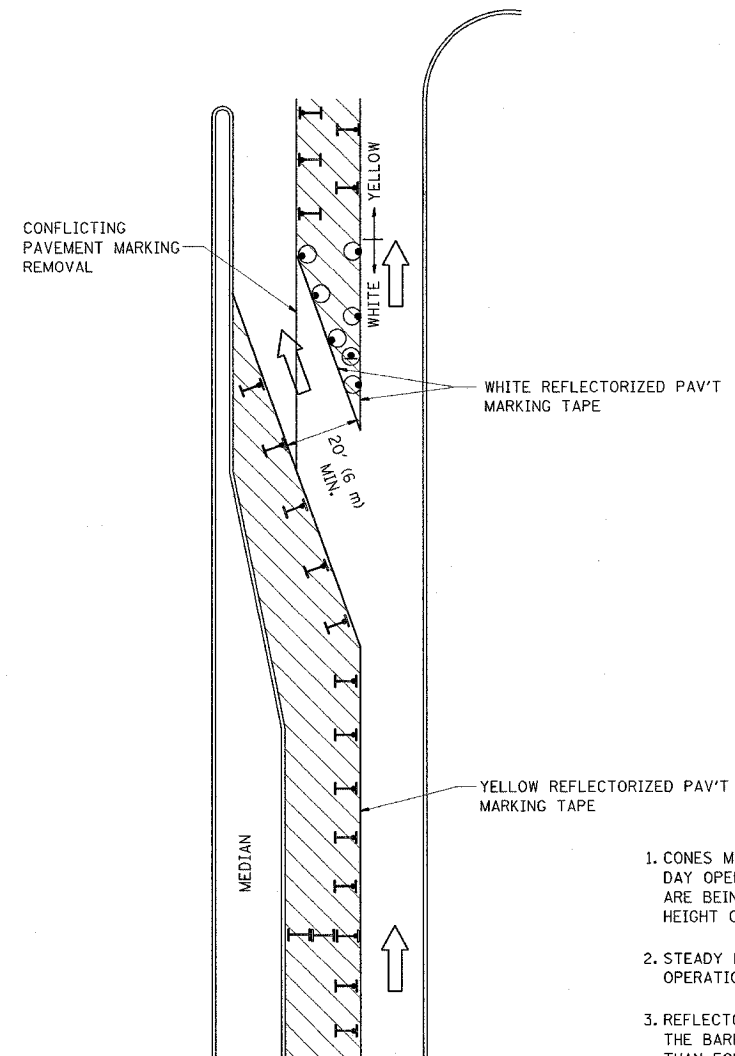



F.A.U. RTE.	SECTION	COUNTY	TOTAL SHEETS	SHEET NO.
3887	(E-1, P, G, & R) RS-5	KANE	43	36
STA.		TO STA.		
FED. ROAD DIST. NO. 1		ILLINOIS	HIGHWAY PROJECT	

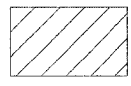

GENERAL NOTES

1. CONES MAY BE SUBSTITUTED FOR BARRICADES OR DRUMS AT HALF THE SPACING DURING DAY OPERATIONS. CONES SHALL BE A MINIMUM OF 28 (710) IN HEIGHT. WHEN CONES ARE BEING USED, THE "LEFT TURN LANE" SIGN MAY BE SKID MOUNTED AT A MINIMUM HEIGHT OF 5' (1.5 m).
2. STEADY BURNING LIGHTS WILL NOT BE REQUIRED ON BARRICADES OR DRUMS FOR DAY OPERATIONS. ALL LIGHTS SHALL BE MONODIRECTIONAL.
3. REFLECTORIZED TEMPORARY PAVEMENT MARKING TAPE SHALL BE PLACED THROUGHOUT THE BARRICADED AREA OF EACH TURN BAY WHERE THE CLOSURE TIME IS GREATER THAN FOURTEEN DAYS.
4. THIS APPLICATION ALSO APPLIES WHEN WORK IS BEING PERFORMED IN THE RIGHT LANE(S) AND THE RIGHT TURN BAY IS TO REMAIN OPEN. UNDER THIS CONDITION, "RIGHT TURN LANE" R3-100 24 x 24 (600 x 600) AND M6-2R 21 x 15 (530 x 380) SHALL BE USED.
5. THESE CONTROLS SHALL SUPPLEMENT MAINLINE TRAFFIC CONTROL FOR LANE CLOSURES.
6. LONGITUDINAL DIMENSIONS MAY BE ADJUSTED TO FIT FIELD CONDITIONS.
7. FORM BT 725 IS REQUIRED.
8. TRAFFIC CONTROL AND PROTECTION AT TURN BAYS (TO REMAIN OPEN TO TRAFFIC) SHALL BE INCLUDED IN THE COST SPECIFIED TRAFFIC CONTROL STANDARDS OR ITEMS.

LEGEND

-  WORK AREA
-  LANE OPEN TO TRAFFIC
-  TYPE I OR II BARRICADE WITH STEADY BURN LIGHT
-  DRUM WITH STEADY BURN LIGHT
-  DRUM WITH SIGN (WITH OPTIONAL FLASHING LIGHT) SEE DETAIL
-  TYPE I OR II CHECK BARRICADE WITH FLASHING LIGHT

All dimensions are in inches (millimeters) unless otherwise shown.

REVISIONS	
NAME	DATE
T. RAMMACHER	09/08/94
A. HOUSEH	11/07/95
A. HOUSEH	10/12/96
T. RAMMACHER	01/06/00

ILLINOIS DEPARTMENT OF TRANSPORTATION
TRAFFIC CONTROL AND PROTECTION AT TURN BAYS (TO REMAIN OPEN TO TRAFFIC)

SCALE: NONE
 DRAWN BY
 CHECKED BY LHA
 TC-14

PLOT DATE = 4/17/2007
 FILE NAME = S:\WORK\PROJECTS\SOULD\1\00a.DWG\ceadd_standard\ct14.dgn
 USER NAME = jzhang

F.A.U. RTE.	SECTION	COUNTY	TOTAL SHEETS	SHEET NO.
3887	(E-L, P, G, H & R) RS-5	3887	43	39
STA.	TO STA.			
FED. ROAD DIST. NO. 1	ILLINOIS	HIGHWAY PROJECT		

LOOPS NEXT TO SHOULDERS

PROVIDE A PAVEMENT REPLACEMENT NOTE WHICH SHOULD EQUAL 3' (900 mm) X WIDTH OF PAVED SHOULDER.

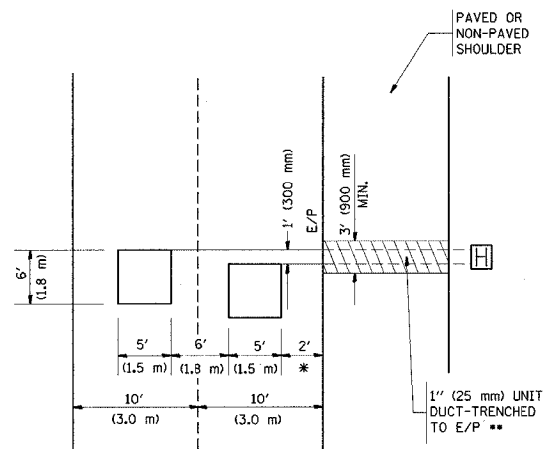

* = (600 mm)

** UNIT DUCT IS TO BE SHOWN ON PLAN SHEETS BUT SHALL NOT BE INCLUDED IN THE PAY ITEMS.

LEFT TURN LANES WITH MEDIANS
VOLUME DENSITY ("FAR OUT" DETECTION)
ON SAME APPROACH
(PROTECTED / PERMITTED LEFT TURN PHASING)

HANDHOLE LOCATION MAY VARY DEPENDING ON GEOMETRICS AND DESIGN OF TRAFFIC SIGNALS. HEAVY-DUTY HANDHOLES TO BE USED WHEN THE MEDIAN IS MOUNTABLE. REFER TO STANDARD 814001 TO ENSURE THAT HANDHOLE FITS IN MEDIAN.

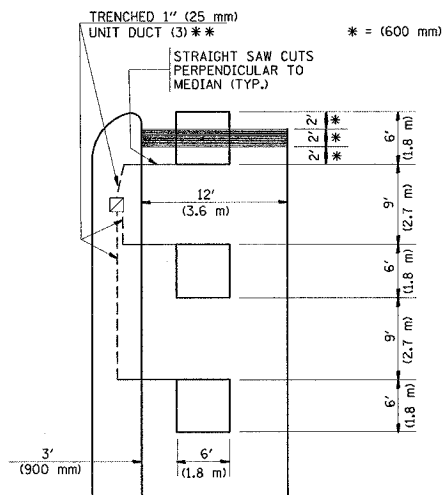

** UNIT DUCT IS TO BE SHOWN ON PLAN SHEETS BUT SHALL NOT BE INCLUDED IN THE PAY ITEMS.

NOTE: DUAL LEFT TURNS NOT SHOWN REFER TO PLAN SHEET FOR DETECTOR LOOP REPLACEMENT

LEFT TURN LANES WITHOUT MEDIANS
VOLUME DENSITY ("FAR OUT" DETECTION)
ON SAME APPROACH
(PROTECTED / PERMITTED LEFT TURN PHASING)

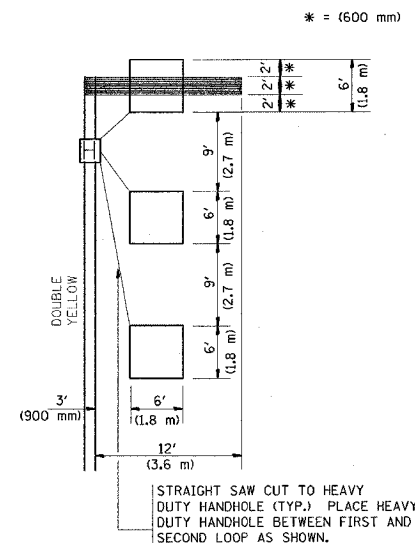

NOTE: DUAL LEFT TURNS NOT SHOWN REFER TO PLAN SHEET FOR DETECTOR LOOP REPLACEMENT

NOTES:

VEHICLES LOOP DETECTORS

- * ALL LEAD IN CABLE SHALL BE TWO CONDUCTOR NO. 14 TWISTED, SHIELDED.
- * EACH DETECTOR LOOP SHALL HAVE ITS OWN SAW CUT FROM THE LOOP TO THE EDGE OF PAVEMENT OR TO A HANDHOLE IN THE PAVEMENT.
- * EACH DETECTOR LOOP SHALL HAVE ITS OWN ONE INCH (25 mm) UNIT DUCT BETWEEN THE EDGE OF PAVEMENT AND THE FIRST HANDHOLE OR JUNCTION BOX. EACH UNIT DUCT RUN SHALL BE SHOWN ON THE PLANS BY THE DESIGNER, BUT SHALL NOT BE PAID FOR SEPARATELY. THIS ITEM IS INCIDENTAL TO THE PAY ITEM FOR DETECTOR LOOPS.
- * ONE DIMENSION OF ALL DETECTOR LOOPS SHALL BE SIX FEET (1.8 m)
- * EACH LANE OF NON-LOCKING, PRESENCE DETECTION AND EACH LANE OF A DOUBLE LEFT TURN LANE REQUIRES A SEPARATE INDUCTIVE LOOP DETECTOR AND LEAD IN CABLE.
- * WHEN NON-LOCKING, PRESENCE DETECTION IS USED, MORE THAN ONE LOOP PER LANE IS REQUIRED BEHIND THE STOP BAR (i.e. 1-1/2, 1-3/4, 2).
- * WHEN SYSTEM LOOPS ARE REQUIRED ON AN APPROACH OF AN INTERSECTION, THE LOOPS USED FOR VOLUME DENSITY AND INTERSECTION TIMING SHALL ALSO BE USED AS SYSTEM DETECTORS. EACH ONE OF THESE TYPE OF LOOPS REQUIRES A SEPARATE TWO CONDUCTOR NO. 14 TWISTED SHIELDED CABLE AND A SEPARATE INDUCTIVE LOOP DETECTOR WHEN NEW CONTROLLERS ARE UTILIZED. THE DESIGNER SHALL LABEL THESE TYPES OF LOOPS AS "INTERSECTION AND SAMPLING (SYSTEM) DETECTORS" ON THE SIGNAL LAYOUT, THE INTERCONNECT PLAN AND THE SYSTEM CABLE PLAN. WHEN AN EXISTING CONTROLLER IS UTILIZED FOR THIS TYPE OF DETECTION, THE PAY ITEM "INDUCTIVE LOOP DETECTOR WITH SYSTEM OUTPUT" SHOULD BE USED.

PLACEMENT OF DETECTORS

THE FOLLOWING FIGURES REPRESENT THE MOST COMMON DETECTOR LOOP LOCATIONS AND SIZES. ADJUSTMENTS WILL BE NECESSARY FOR SPECIFIC GEOMETRIC CONSIDERATIONS.

LOCATIONS AND DIMENSIONS OF DETECTOR LOOPS ARE REQUIRED ON ALL SIGNAL LAYOUT PLAN SHEETS.

"FAR OUT" DETECTION REFERS TO LOCKING, PRESENCE TYPE DETECTION LOCATED IN THRU LANES, RIGHT TURN LANES, AND RIGHT TURN LANE TAPER AREAS (IF APPLICABLE), USUALLY 250' (75 m) IN ADVANCE OF STOP BARS. "UPTIGHT" DETECTION REFERS TO NON-LOCKING PRESENCE TYPE DETECTION LOCATED IN ALL LANES AND 10'-15' (3.0 m-4.5 m) BEHIND THE CROSSING STREET'S EDGE OF PAVEMENT EXTENDED.

NOTE:

ALL DETAILS AND NOTES SHOWN ARE FROM THE I.D.O.T. DISTRICT 1 TRAFFIC SIGNAL DESIGN GUIDELINES DATED JANUARY 1995

THIS DRAWING HAS BEEN PREPARED TO ASSIST THE RESIDENT ENGINEER FOR ALL ROADWAY RESURFACING OR S.M.A.R.T. PROJECTS WHERE THE DIMENSIONS ARE NOT SHOWN ON THE PLANS AND THE FINAL LOCATIONS FOR CROSSWALKS OR STOP BARS ARE NOT DETERMINED.

REVISIONS	
NAME	DATE

ILLINOIS DEPARTMENT OF TRANSPORTATION
DISTRICT 1
DETECTOR LOOP
INSTALLATION DETAILS
FOR ROADWAY RESURFACING
DESIGNED BY
DRAWN BY CADD
CHECKED BY R.K.F.
TS07

ARTERIAL-VOLUME DENSITY ("FAR OUT" DETECTION)
CROSS STREET-VOLUME DENSITY ("FAR OUT" DETECTION)

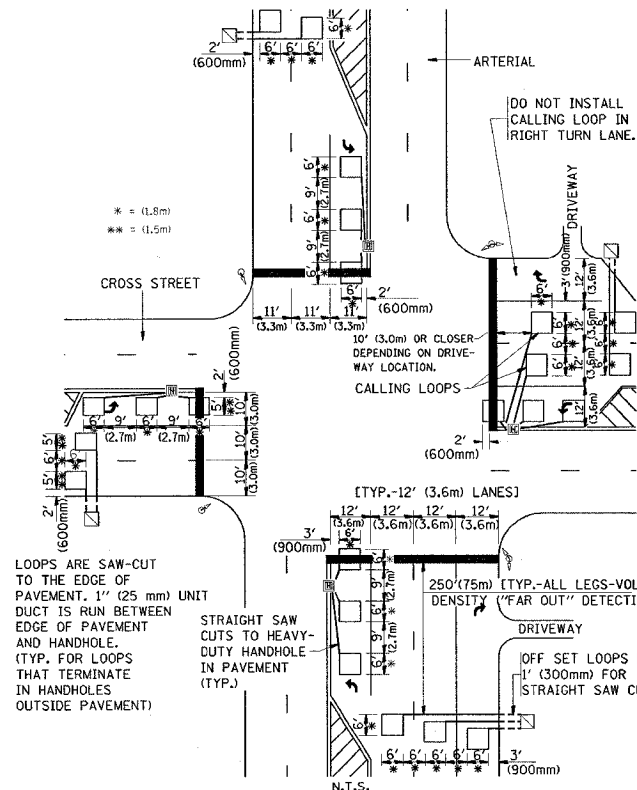

DETAIL 1
N.T.S.

ARTERIAL-VOLUME DENSITY ("FAR OUT" DETECTION)
CROSS STREET-NON VOLUME DENSITY ("UPTIGHT" PRESENCE DETECTION)

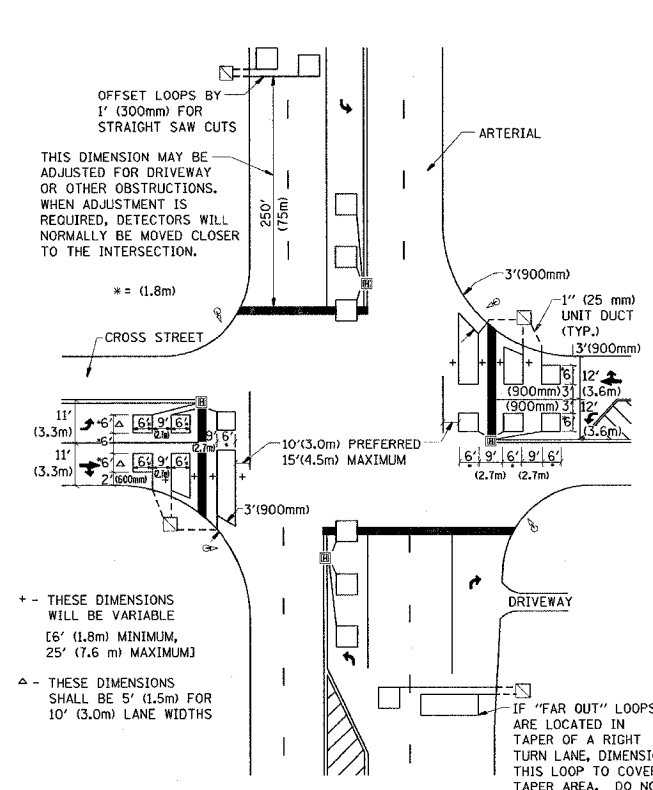

DETAIL 2
N.T.S.

PLOT DATE = 4/18/2007
FILE NAME = S:\P\PLANS\REFS\SIGNAL\Des.D\Tosadd_standards\ts07.dgn
PLOT SCALE = 50.0000 / 1 IN.
USER NAME = trent

F.A.U. RTE.	SECTION	COUNTY	TOTAL SHEETS	SHEET NO.
3887	(E-L, P, G, H & R) RS-5	KANE	43	40
STA.	TO STA.			
FED. ROAD DIST. NO. 1	ILLINOIS	HIGHWAY PROJECT		

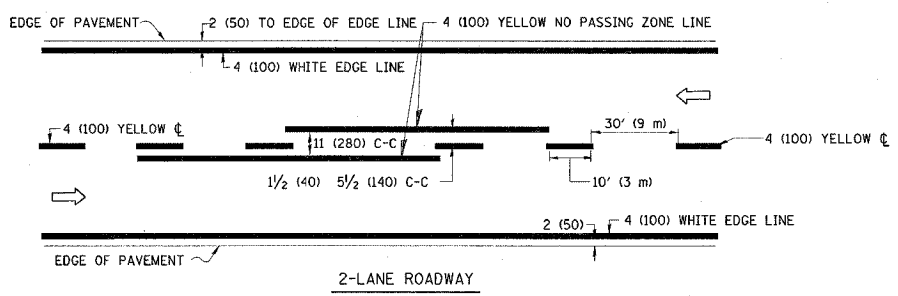

2-LANE ROADWAY

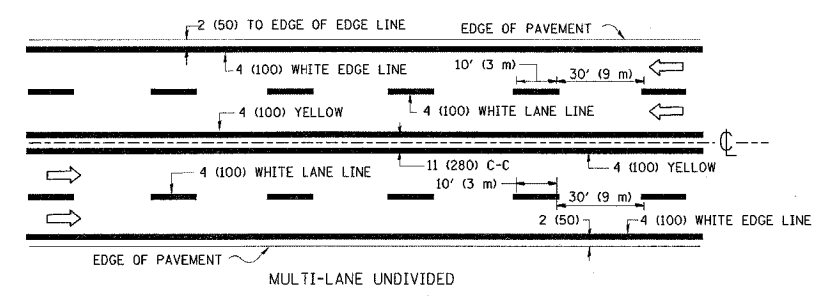

MULTI-LANE UNDIVIDED

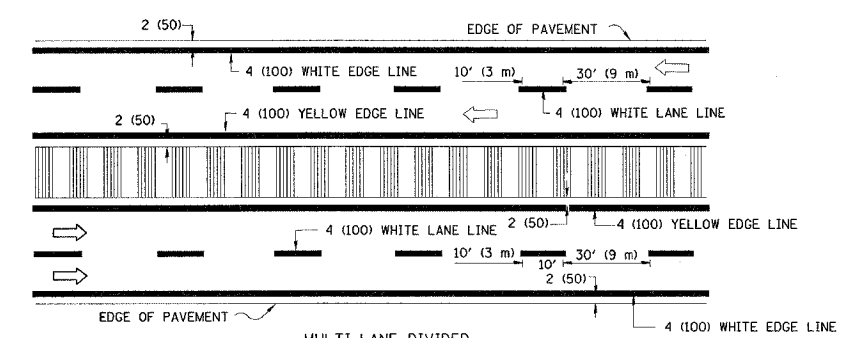

MULTI-LANE DIVIDED WITH MOUNTABLE MEDIAN

NOTE: MEDIANS WITH BARRIER CURB DO NOT REQUIRE AN EDGE LINE

TYPICAL LANE AND EDGE LINE MARKING

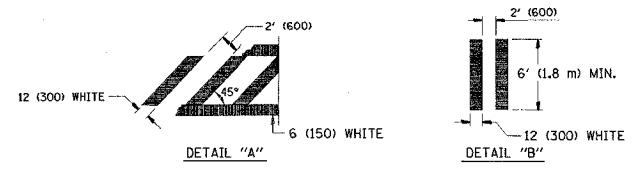
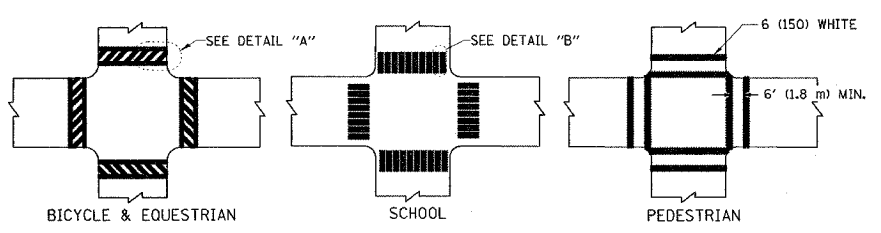

TYPICAL CROSSWALK MARKING

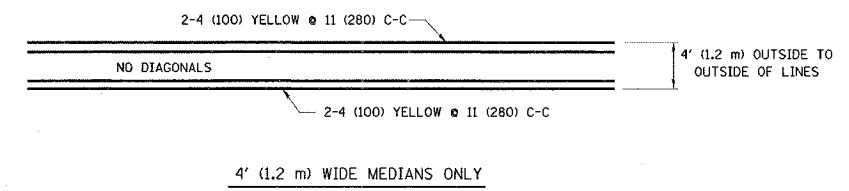

4' (1.2 m) WIDE MEDIANS ONLY

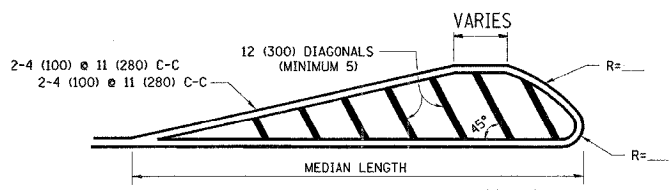

FOR MEDIAN LENGTHS WHERE DIAGONAL SPACING CANNOT BE ATTAINED, USE 5 (FIVE) EQUALLY SPACED DIAGONAL LINES.
 DIAGONAL LINE SPACING: 50' (15 m) C-C (LESS THAN 30MPH (50 km/h))
 75' (25 m) C-C 30MPH (50 km/h) TO 45MPH (70 km/h)
 150' (45 m) C-C (MORE THAN 45MPH (70 km/h))

MEDIANS OVER 4' (1.2 m) WIDE

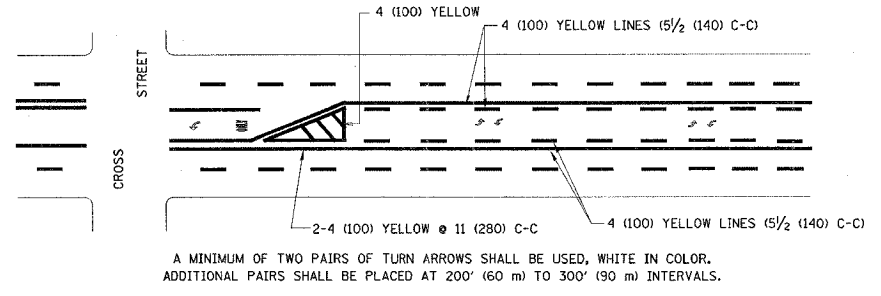

A MINIMUM OF TWO PAIRS OF TURN ARROWS SHALL BE USED, WHITE IN COLOR. ADDITIONAL PAIRS SHALL BE PLACED AT 200' (60 m) TO 300' (90 m) INTERVALS.

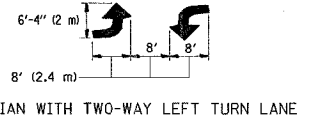

MEDIAN WITH TWO-WAY LEFT TURN LANE

TYPICAL PAINTED MEDIAN MARKING

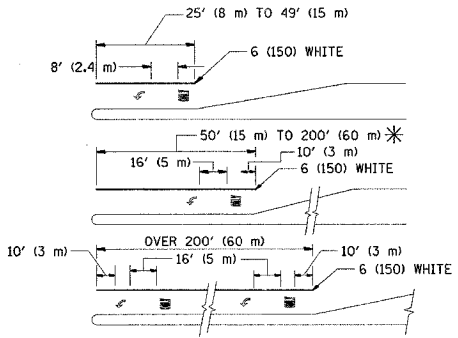

FULL SIZE LETTERS 8' (2.4 m) AND ARROWS SHALL BE USED.
 AREA = 15.6 SQ. FT. (1.5 m²) ONLY AREA = 20.8 SQ. FT. (1.9 m²)

* TURN LANES IN EXCESS OF 400' (120 m) IN LENGTH MAY HAVE AN ADDITIONAL SET OF ARROW - "ONLY" INSTALLED MIDWAY BETWEEN THE OTHER TWO SETS OF ARROW - "ONLY".

TYPICAL LEFT (OR RIGHT) TURN LANE

TYPICAL TURN LANE MARKING

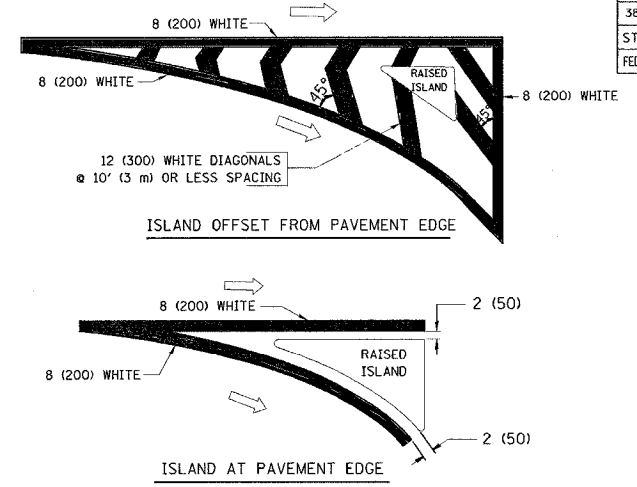

ISLAND OFFSET FROM PAVEMENT EDGE

ISLAND AT PAVEMENT EDGE

TYPICAL ISLAND MARKING

TYPE OF MARKING	WIDTH OF LINE	PATTERN	COLOR	SPACING / REMARKS
CENTERLINE ON 2 LANE PAVEMENT	4 (100)	SKIP-DASH	YELLOW	10' (3 m) LINE WITH 30' (9 m) SPACE
CENTERLINE ON MULTI-LANE UNDIVIDED PAVEMENT	2 @ 4 (100)	SOLID	YELLOW	11 (280) C-C
NO PASSING ZONE LINES: FOR ONE DIRECTION FOR BOTH DIRECTIONS	4 (100) 2 @ 4 (100)	SOLID SOLID	YELLOW YELLOW	5/2 (140) C-C FROM SKIP-DASH CENTERLINE 11 (280) C-C OMIT SKIP-DASH CENTERLINE BETWEEN
LANE LINES	4 (100) 5 (125) ON FREEWAYS	SKIP-DASH SKIP-DASH	WHITE WHITE	10' (3 m) LINE WITH 30' (9 m) SPACE
DOTTED LINES (EXTENSIONS OF CENTER, LANE OR TURN LANE MARKINGS)	SAME AS LINE BEING EXTENDED	SKIP-DASH	SAME AS LINE BEING EXTENDED	2' (600) LINE WITH 6' (1.8 m) SPACE
EDGE LINES	4 (100)	SOLID	YELLOW-LEFT WHITE-RIGHT	OUTLINE MOUNTABLE MEDIANS IN YELLOW; EDGE LINES ARE NOT USED NEXT TO BARRIER CURB
TURN LANE MARKINGS	6 (150) LINE; FULL SIZE LETTERS & SYMBOLS (8' (2.4m))	SOLID	WHITE	SEE TYPICAL TURN LANE MARKING DETAIL
TWO WAY LEFT TURN MARKING	2 @ 4 (100) EACH DIRECTION 8' (2.4m) LEFT ARROW	SKIP-DASH AND SOLID IN PAIRS	YELLOW WHITE	10' (3 m) LINE WITH 30' (9 m) SPACE FOR SKIP-DASH; 5/2 (140) C-C BETWEEN SOLID LINE AND SKIP-DASH LINE SEE TYPICAL TWO-WAY LEFT TURN MARKING DETAIL
CROSSWALK LINES (PEDESTRIAN) A. DIAGONALS (BIKE & EQUESTRIAN) B. LONGITUDINAL BARS (SCHOOL)	2 @ 6 (150) 12 (300) @ 45° 12 (300) @ 90°	SOLID SOLID SOLID	WHITE WHITE WHITE	NOT LESS THAN 6' (1.8 m) APART 2' (600) APART 2' (600) APART SEE TYPICAL CROSSWALK MARKING DETAILS.
STOP LINES	24 (600)	SOLID	WHITE	PLACE 4' (1.2 m) IN ADVANCE OF AND PARALLEL TO CROSSWALK, IF PRESENT. OTHERWISE, PLACE AT DESIRED STOPPING POINT. PARALLEL TO CROSSROAD CENTERLINE, WHERE POSSIBLE
PAINTED MEDIANS	2 @ 4 (100) WITH 12 (300) DIAGONALS @ 45° NO DIAGONALS USED FOR 4' (1.2 m) WIDE MEDIANS	SOLID	YELLOW: TWO WAY TRAFFIC WHITE: ONE WAY TRAFFIC	11 (280) C-C FOR THE DOUBLE LINE SEE TYPICAL PAINTED MEDIAN MARKING.
GORE MARKING AND CHANNELIZING LINES	8 (200) WITH 12 (300) DIAGONALS @ 45°	SOLID	WHITE	DIAGONALS: 15' (4.5 m) C-C (LESS THAN 30MPH (50 km/h)) 20' (6 m) C-C 30MPH (50 km/h) TO 45MPH (70 km/h) 30' (9 m) C-C (OVER 45MPH (70 km/h))
RAILROAD CROSSING	24 (600) TRANSVERSE LINES; "RR" IS 6' (1.8 m) LETTERS; 16 (400) LINE FOR "X"	SOLID	WHITE	SEE STATE STANDARD 780001 AREA OF: "R"=3.6 SQ. FT. (0.33 m ²) EACH "X"=54.0 SQ. FT. (5.0 m ²)
SHOULDER DIAGONALS	12 (300) @ 45°	SOLID	WHITE - RIGHT YELLOW - LEFT	50' (15 m) C-C (LESS THAN 30MPH (50 km/h)) 75' (25 m) C-C (30 MPH (50 km/h) TO 45MPH (70 km/h)) 150' (45 m) C-C (OVER 45MPH (70 km/h))

FOR FURTHER DETAILS ON PAVEMENT MARKING REFER TO STANDARD SPECIFICATIONS FOR ROAD AND BRIDGE CONSTRUCTION AND STATE STANDARD 780001.

All dimensions are in inches (millimeters) unless otherwise shown.

REVISIONS	
NAME	DATE
EVERS	03-19-90
T. RAMMACHER	10-27-94
ALEX HOUSEH	10-09-96
ALEX HOUSEH	10-17-96
T. RAMMACHER	01-06-00

ILLINOIS DEPARTMENT OF TRANSPORTATION

DISTRICT ONE TYPICAL PAVEMENT MARKINGS

SCALE: NONE

DRAWN BY CADD
CHECKED BY

PLOT DATE = 4/17/2007
 FILE NAME = S:\WORK\INPROG\SDM\1\Des.DWG\cadd standard-1.tbl
 PLOT SCALE = 1"=100'
 USER NAME = tcratt

F.A.U. RTE.	SECTION	COUNTY	TOTAL SHEETS	SHEET NO.
3887	(E-1, P, G, H & R) RS-5	KANE	43	41
STA.		TO STA.		
FED. ROAD DIST. NO. 1	ILLINOIS	HIGHWAY PROJECT		

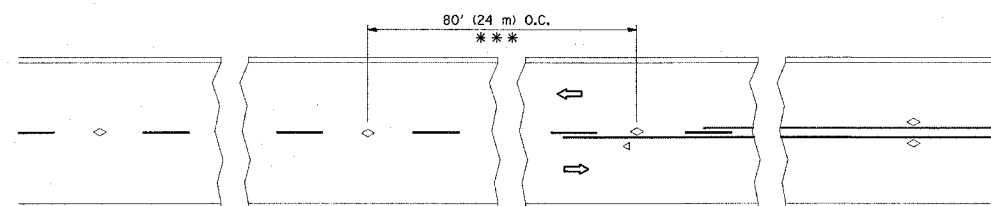

*** REDUCE TO 40' (12 m) O.C. ON CURVES WITH POSTED OR ADVISORY SPEED 45 M.P.H. (70 km/h) OR LESS.

TWO-LANE/TWO-WAY

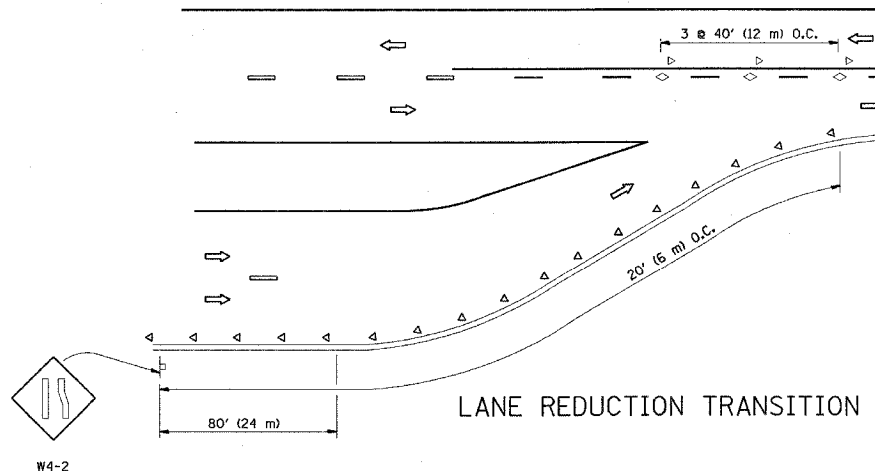

LANE REDUCTION TRANSITION

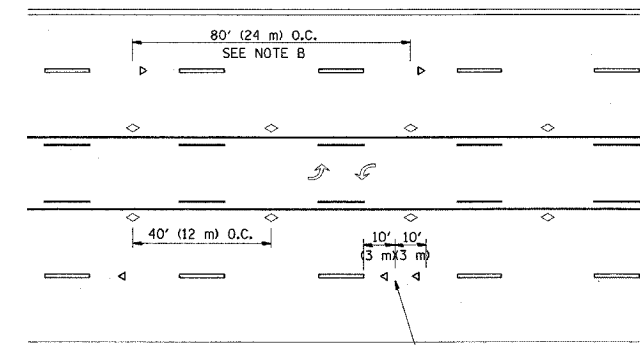

TWO-WAY LEFT TURN

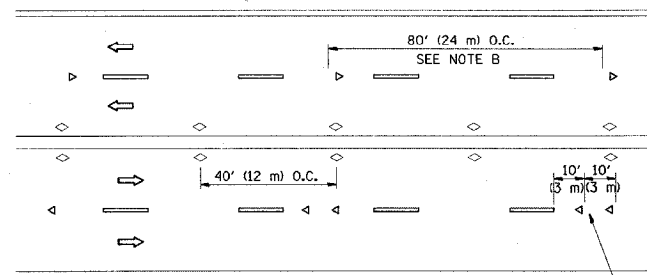

MULTI-LANE/UNDIVIDED

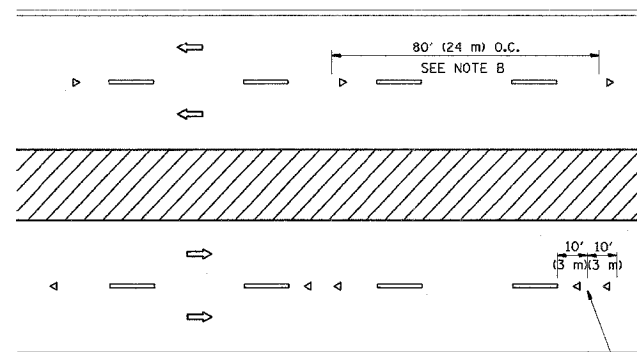

MULTI-LANE/DIVIDED

GENERAL NOTES

1. MARKERS USED WITH DASHED LINES SHALL BE CENTERED IN THE GAP BETWEEN SEGMENTS.
2. MARKERS USED ADJACENT TO SOLID LINES SHALL BE OFFSET 2 TO 3 (50 TO 75) TOWARD TRAFFIC AS SHOWN.
3. MARKERS THROUGH TANGENTS LESS THAN 500' (150 m) IN LENGTH BETWEEN CURVES SHALL BE INSTALLED AT THE LESSER OF THE TWO CURVE SPACINGS.

SYMBOLS

- YELLOW STRIPE
- WHITE STRIPE
- ◁ ONE-WAY AMBER MARKER
- ◁ ONE-WAY CRYSTAL MARKER (W/O)
- ◇ TWO-WAY AMBER MARKER

LANE MARKER NOTES

- B. REDUCE TO 40' (12 m) O.C. ON CURVES WHERE ADVISORY SPEEDS ARE 10 M.P.H (20 km/h) LOWER THAN POSTED SPEEDS.
- A. USE DOUBLE LANE LINE MARKERS SPACED AS SHOWN.

DESIGN NOTES

1. DOUBLE LANE LINE MARKERS SHALL BE USED UNLESS SPECIFIED OTHERWISE.
2. EXCEPT AS SHOWN ON THE LANE REDUCTION TRANSITION AND FREEWAY EXIT RAMP DETAIL, MARKERS ARE NOT TO BE SPECIFIED ON RIGHT EDGE LINES.
3. THE EXACT MARKER LIMITS, SPACING, AND COLOR SHOULD BE INCLUDED IN THE PLANS.
4. MARKERS SHOULD NOT BE USED ALONGSIDE CURBS EXCEPT FOR EXTREMELY SHORT SECTIONS OF CURBS WHERE NOT MORE THAN TWO MARKERS WOULD BE INVOLVED.

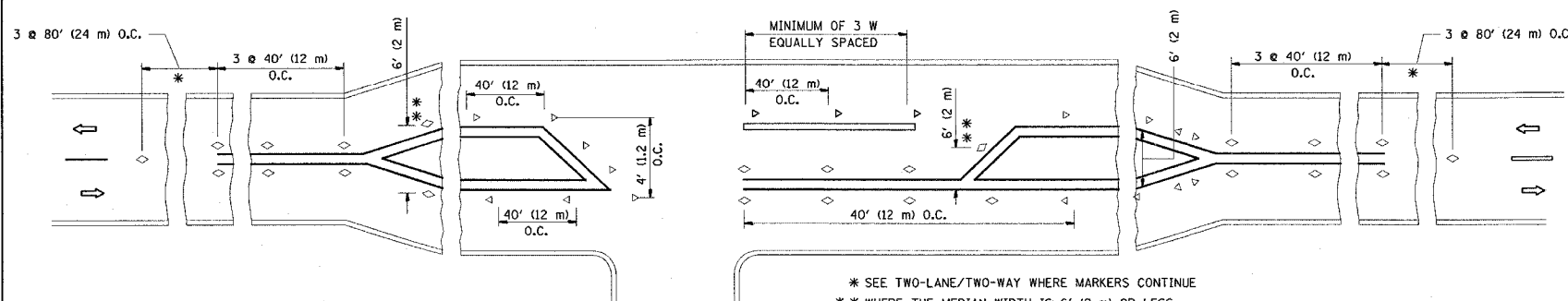

LEFT TURN

* SEE TWO-LANE/TWO-WAY WHERE MARKERS CONTINUE
 ** WHERE THE MEDIAN WIDTH IS 6' (2 m) OR LESS USE TWO-WAY MARKERS.

All dimensions are in inches (millimeters) unless otherwise shown.

REVISIONS	
NAME	DATE
T. RAMMACHER	09-19-94
T. RAMMACHER	03-12-99
T. RAMMACHER	01-06-00

ILLINOIS DEPARTMENT OF TRANSPORTATION
 TYPICAL APPLICATIONS
 RAISED REFLECTIVE PAVEMENT
 MARKERS (SNOW-PLOW RESISTANT)

SCALE: NONE

DRAWN BY CADD
 CHECKED BY
 TC-11

PLOT DATE = 4/17/2007
 FILE NAME = S:\VPL\ANPREP\SDIAD\1\Des_Dm\cadd\standard\lcll.dgn
 PLOT SCALE = 50.0000 / IN.
 USER NAME = tca

F.A.U. RTE.	SECTION	COUNTY	TOTAL SHEETS	SHEET NO.
3887	(E-1, P, G, H & R) RS-5	KANE	43	42
STA.		TO STA.		
FED. ROAD DIST. NO. 1	ILLINOIS	HIGHWAY PROJECT		

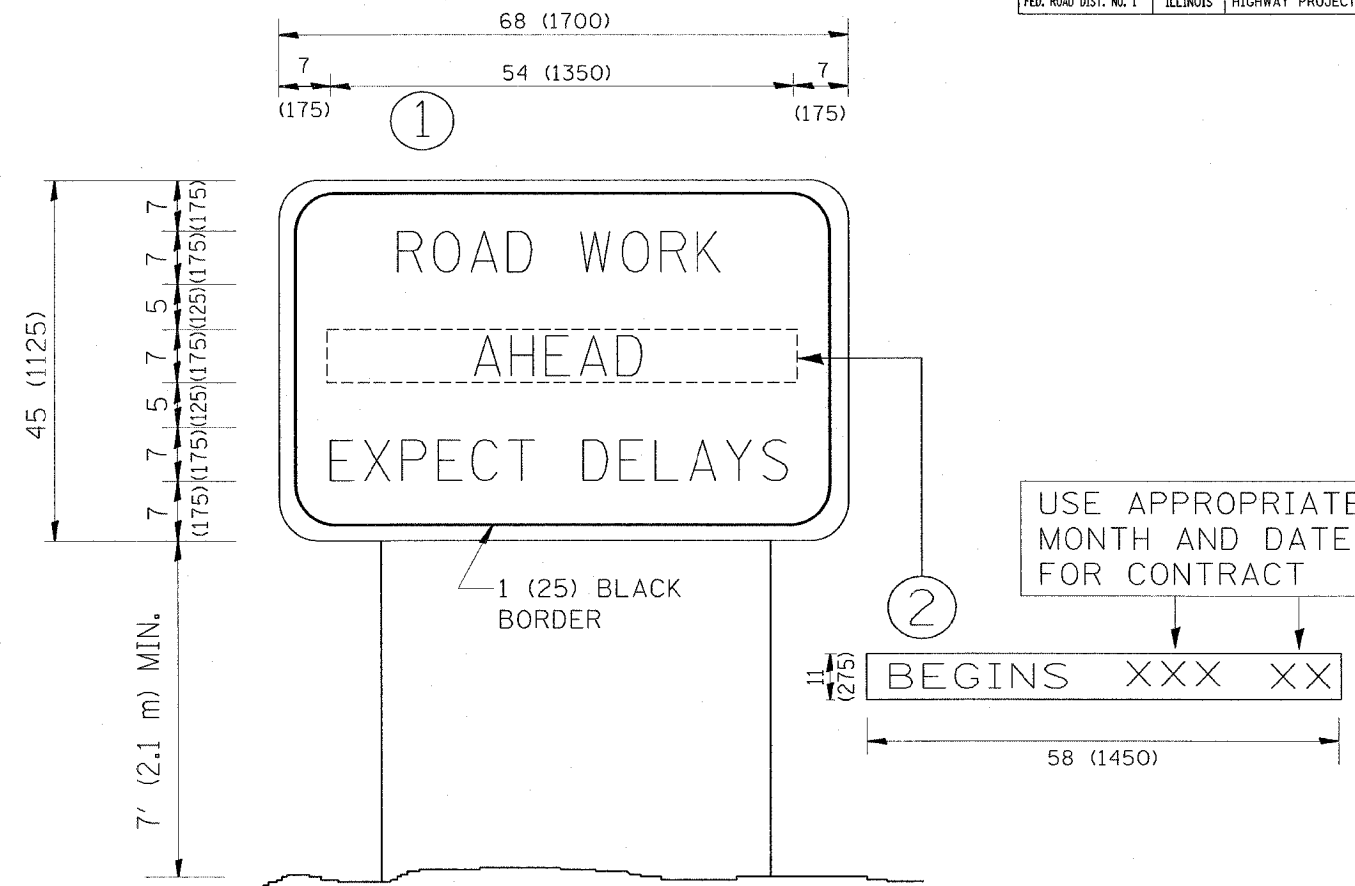

NOTES:

1. USE BLACK LETTERING ON ORANGE BACKGROUND.
2. ERECT SIGNS IN ADVANCE OF THE LOCATION FOR THE "ROAD CONSTRUCTION AHEAD" SIGN AT LOCATIONS AS DIRECTED BY THE ENGINEER.
3. ERECT SIGN ① WITH INSTALLED PANEL ② ONE WEEK PRIOR TO THE START OF CONSTRUCTION.
4. REMOVE PANEL ② SOON AFTER THE START OF CONSTRUCTION.
5. SEE SPECIAL PROVISION FOR "TEMPORARY INFORMATION SIGNING" FOR ADDITIONAL INFORMATION.
6. ONE SIGN ASSEMBLY EQUALS 25.70 SQ. FT. (2.3 SQ. M.)
7. SHALL BE PAID FOR AS TEMPORARY INFORMATION SIGNING.

ALL DIMENSIONS ARE IN INCHES (MILLIMETERS) UNLESS OTHERWISE SHOWN.

REVISIONS	
NAME	DATE
R. MIRS	9-15-97
R. MIRS	12-11-97
T. RAMMACHER	2-2-99
C. JUCLUS	1-31-07

ILLINOIS DEPARTMENT OF TRANSPORTATION

ARTERIAL ROAD INFORMATION SIGN

SCALE: NONE

DRAWN BY DESIGN

CHECKED BY

TC22

F.A.U. RTE.	SECTION	COUNTY	TOTAL SHEETS	SHEET NO.
3887	(E-1, P, G, H & R) RS-5	KANE	43	43
STA.		TO STA.		
FED. ROAD DIST. NO. 1		ILLINOIS	HIGHWAY PROJECT	

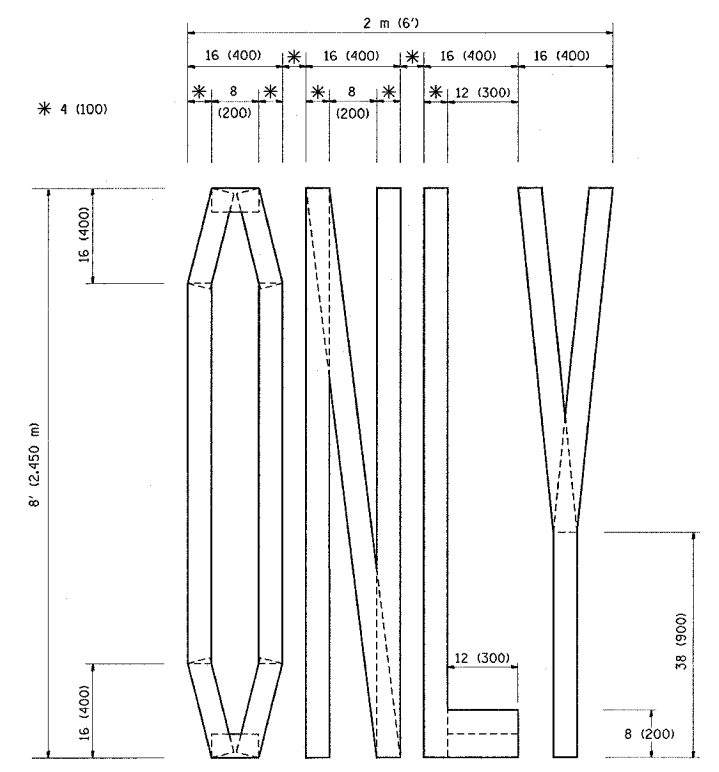

QUANTITY
4 (100) LINE = 64.1 ft. (19.7 m)
21.1 sq. ft. (1.97 sq. m)

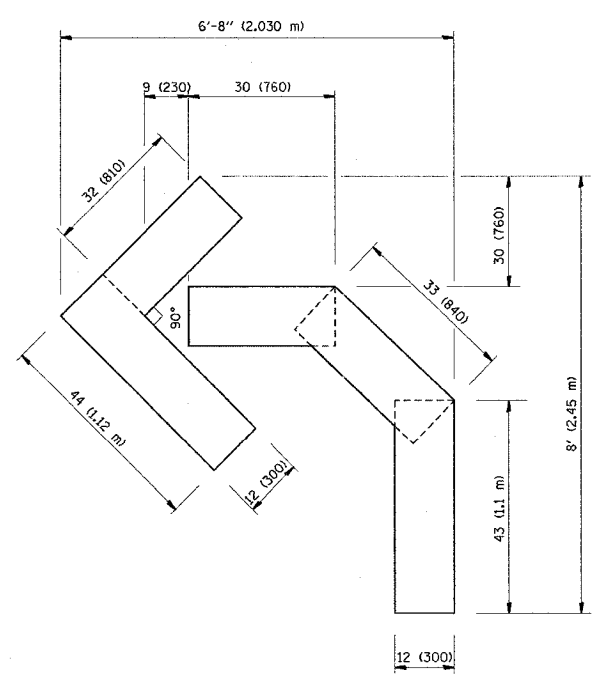

QUANTITY
4 (100) LINE = 45.5 ft. (13.9 m)
15.2 sq. ft. (1.39 sq. m)

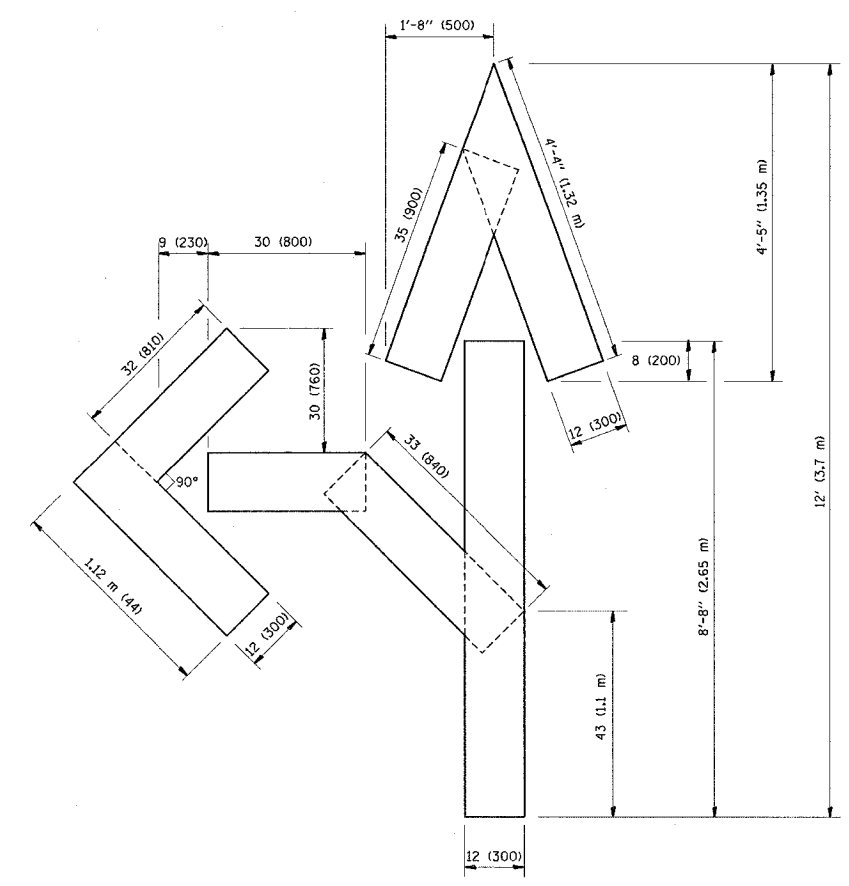

QUANTITY
4 (100) LINE = 82.5 ft. (25.3 m)
27.5 sq. ft. (2.53 sq. m)

All dimensions are in inches (millimeters) unless otherwise shown.

REVISIONS	
NAME	DATE
T. RAMMACHER	09/18/94
J. OBERLE	06/01/96
T. RAMMACHER	06/05/98
T. RAMMACHER	11/04/97
T. RAMMACHER	03/02/98
E. GOMEZ	08/28/00

ILLINOIS DEPARTMENT OF TRANSPORTATION

PAVEMENT MARKING
LETTERS AND SYMBOLS
FOR TRAFFIC STAGING

SCALE: NONE
DRAWN BY CADD
CHECKED BY
TC-16

PLOT DATE = 4/18/2007
PLOT SCALE = 1/8" = 1'-0"
USER NAME = tcrant