

F.A.P. RTE.	SECTION	COUNTY	TOTAL SHEETS	SHEET NO.
846	(4,4R&5)RS-7	WILL	35	1

CONTRACT NO.: 62364

STATE OF ILLINOIS
DEPARTMENT OF TRANSPORTATION
DIVISION OF HIGHWAYS

PROPOSED HIGHWAY PLANS
F.A.P. 846 (IL 53)
MANHATTAN RD. TO OLD ELM RD.
SECTION: (4, 4R, & 5) RS-7
RESURFACING (MAINTENANCE)
AND BRIDGE DECK REPAIR
STRUCTURE NO.: 099-0086, 099-0087
WILL COUNTY
C-91-002-02

D-91-002-02

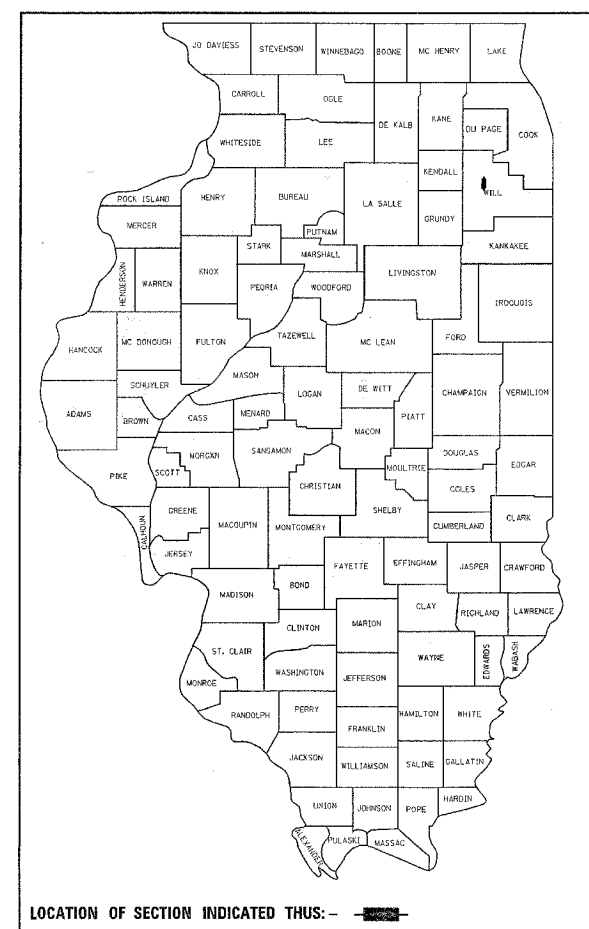

LOCATION OF SECTION INDICATED THUS: - [shaded area] -

FOR INDEX OF SHEETS, SEE SHEET NO. 2

IMPROVEMENT LOCATED IN THE CITY OF JOLIET AND THE VILLAGE OF ELWOOD

IMPROVEMENT ENDS
STA. 261 + 20

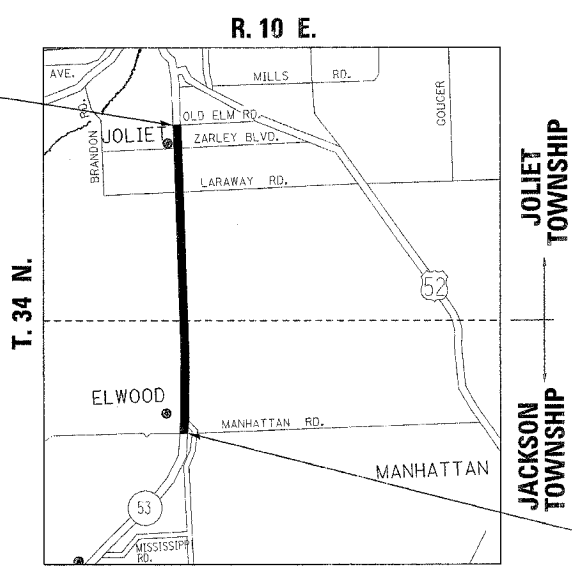

IMPROVEMENT BEGINS
STA. 9 + 77

TRAFFIC DATA:
2005 ADT - 14100 TO 18200
SPEED LIMIT - 45 TO 55 MPH

OMISSIONS:
JACKSON CREEK
STA. 19 + 89 TO STA. 21 + 91

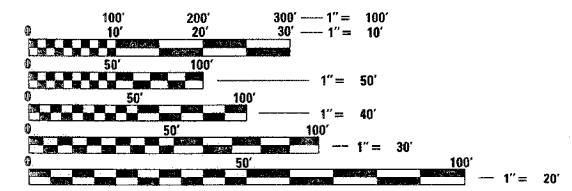

FULL SIZE PLANS HAVE BEEN PREPARED USING STANDARD ENGINEERING SCALES. REDUCED SIZED PLANS WILL NOT CONFORM TO STANDARD SCALES. IN MAKING MEASUREMENTS ON REDUCED PLANS, THE ABOVE SCALES MAY BE USED.

J.U.L.I.E.
JOINT UTILITY LOCATION INFORMATION FOR EXCAVATION
1-800-892-0123

GROSS LENGTH OF IMPROVEMENT - 25143 LINEAR FEET - 4.76 MILES
NET LENGTH OF IMPROVEMENT - 24941 LINEAR FEET - 4.72 MILES

STATE OF ILLINOIS
DEPARTMENT OF TRANSPORTATION
DIVISION OF HIGHWAYS

SUBMITTED *March 27 20 07*
Diane O'Keefe/ed DISTRICT ENGINEER

May 11, 2007
Eric E. Harn/ed ENGINEER OF DESIGN AND ENVIRONMENT

May 11, 20 07
Milton R. See/pe/ed DIRECTOR, DIVISION OF HIGHWAYS

PRINTED BY THE AUTHORITY OF THE STATE OF ILLINOIS

DIST. 1 DESIGN - PLAN PREPARATION ENGINEER: KEN ENG / J. CHANG (847) 705-4432

CONTRACT NO. 62364

F. A. P. RTE.	SECTION	COUNTY	TOTAL SHEETS	SHEET NO.
846	(4, 4R, & 5) RS-7	WILL	35	2
STA.	+	TO STA.	+	
FED. ROAD DIST. NO. 1	ALLIANCE	FED. AID PROJECT		

CONTRACT NO.: 62364

SHEET NO.	INDEX OF SHEETS DESCRIPTION
1	COVER SHEET
2	INDEX OF SHEETS, STATE STANDARDS, AND GENERAL NOTES
3	SUMMARY OF QUANTITIES
4-7	TYPICAL SECTIONS
8-16	ROADWAY AND PAVEMENT MARKING PLANS
17	DETAILS FOR FRAMES AND LIDS ADJUSTMENTS WITH MILLING
18	PAVEMENT PATCHING FOR HMA SURFACED PAVEMENT
19	CURB OR CURB AND GUTTER REMOVAL AND REPLACEMENT
20	BUTT JOINT AND HMA TAPER DETAILS
21	TRAFFIC CONTROL AND PROTECTION FOR SIDEROADS, INTERSECTIONS, AND DRIVEWAYS
22	TYPICAL APPLICATION FOR RAISED REFLECTIVE PAVEMENT MARKERS
23	DISTRICT ONE TYPICAL PAVEMENT MARKINGS
24	TRAFFIC CONTROL AND PROTECTION AT TURN BAYS
25	TEMPORARY PAVEMENT MARKING--LETTERS AND SYMBOLS FOR TRAFFIC STAGING
26-29	STANDARD TRAFFIC DESIGN DETAILS
30	DETECTOR LOOP INSTALLATION FOR ROADWAY RESURFACING
31-32	DETECTOR LOOP LOCATION DETAILS
33-34	BRIDGE DECK AND JOINT REPAIR DETAILS
35	ARTERIAL ROAD INFORMATION SIGNING

STATE STANDARDS

- 000001-04 STANDARD SYMBOLS, ABBREVIATIONS AND PATTERNS
- 442201-02 CLASS C AND D PATCHES
- 604001-02 FRAME AND LIDS, TYPE 1
- 630001-07 STEEL PLATE BEAM GUARDRAIL
- 635006-02 REFLECTOR AND TERMINAL MARKER PLACEMENT
- 635011-01 REFLECTOR MARKER AND MOUNTING DETAILS
- 701301-02 LANE CLOSURE 2L, 2W SHORT TIME OPERATIONS
- 701406-04 LANE CLOSURE MULTILANE FOR SPEEDS > 45 MPH
- 701426-02 LANE CLOSURE MULTILANE INTERMITTENT OR MOVING OPERATION FOR SPEEDS > 45 MPH
- 701701-04 URBAN LANE CLOSURE, MULTILANE INTERSECTION
- 702001-06 TRAFFIC CONTROL DEVICES
- 780001-01 TYPICAL PAVEMENT MARKINGS
- 886001 DETECTOR LOOP INSTALLATIONS
- 886006 TYPICAL LAYOUT FOR DETECTION LOOPS

GENERAL NOTES

BEFORE STARTING ANY EXCAVATION, THE CONTRACTOR SHALL CALL "JULIE" AT 800-892-0123 OR "CUAN" (CHICAGO UTILITY ALERT NETWORK), 312-744-7000 FOR FIELD LOCATIONS OF BURIED ELECTRIC, TELEPHONE AND GAS FACILITIES. (48 HOUR NOTIFICATION IS REQUIRED)

3 METER (10 FEET) TRANSITIONS SHALL BE USED TO MATCH PROPOSED CURB AND GUTTER AND MEDIAN ITEMS OF WORK TO EXISTING CURBS & GUTTERS AND MEDIANS IN THE FIELD, UNLESS OTHERWISE SHOWN. THE TRANSITION SHALL BE PAID FOR AT THE CONTRACT UNIT PRICE FOR THE PROPOSED ITEMS OF WORK SPECIFIED.

THE CONTRACTOR SHALL COORDINATE CONSTRUCTION ACTIVITIES WITH UTILITY COMPANIES.

THE CONTRACTOR WILL NOT BE ALLOWED TO SET UP A YARD OR FIELD OFFICE ON STATE PROPERTY WITHOUT WRITTEN PERMISSION FROM THE DEPARTMENT.

WHEN MILLED PAVEMENT IS OPEN TO TRAFFIC THE MAXIMUM GRADE DIFFERENTIAL BETWEEN PASSES OF THE MILLING MACHINE SHALL NOT EXCEED 40 MM (1 1/2 INCHES) WHERE THE SPEED LIMIT IS 80 KM/H (45 MPH). WITH WRITTEN APPROVAL FROM THE ENGINEER, A MAXIMUM GRADE DIFFERENTIAL OF 75 MM (3 INCHES) MAY BE ALLOWED IF THE EDGE OF THE MILLING IS SLOPED A MINIMUM 1:3 (V:H).

BUTT JOINTS WILL BE INSTALLED AT THE ENDS OF ALL RESURFACING (WHERE RESURFACING MEETS EXISTING PAVEMENT), IN ACCORDANCE WITH THE "BUTT JOINT AND BITUMINOUS TAPER DETAILS" SHEET INCLUDED IN THE PLANS, UNLESS OTHERWISE SPECIFIED.

REVISIONS	
NAME	DATE

ILLINOIS DEPARTMENT OF TRANSPORTATION
INDEX OF SHEETS, STATE STANDARDS,
AND GENERAL NOTES

F.A.P. 846/IL 53 (CHICAGO ST.)
MANHATTAN RD. TO ZARLEY BLVD.

SCALE: VERT. 1"=50'
HORIZ. 1"=50'
DATE 3/20/2007

DRAWN BY: P. STEED
CHECKED BY:

F.A.P. RTE.	SECTION	COUNTY	TOTAL SHEETS	SHEET NO.
846	(4, 4R, & 5) RS-7	WILL	35	3
FED. ROAD DIST. NO. 1		ILLINOIS	HIGHWAY PROJECT	

CONTRACT NO. 62364

SUMMARY OF QUANTITIES			CONSTRUCTION TYPE CODE							
CODE NO	ITEM	UNIT	URBAN TOTAL QUANTITIES 100% STATE							
				I000-2A	BRIDGE REPAIR SFTY-2A					
20201006	GRADING AND SHAPING SHOULDERS	UNIT	471	471						
21400100	GRADING AND SHAPING DITCHES	FOOT	21693	21693						
40600200	BITUMINOUS MATERIALS (PRIME COAT)	TON	63	63						
40600300	AGGREGATE (PRIME COAT)	TON	313	313						
40600400	MIXTURE FOR CRACKS, JOINTS, AND FLANGWAYS	TON	47	47						
40600895	CONSTRUCTING TEST STRIP	EACH	1	1						
40600982	HOT-MIX ASPHALT SURFACE REMOVAL - BUTT JOINT	SQ YD	635	635						
40600990	TEMPORARY RAMP	SQ YD	635	635						
40601005	HOT-MIX ASPHALT REPLACEMENT OVER PATCHES	TON	2668	2668						
40603085	HOT-MIX ASPHALT BINDER COURSE, IL-19.0, N70	TON	1141	1141						
40603310	HOT-MIX ASPHALT SURFACE COURSE, MIX "C", N50	TON	204	204						
40603340	HOT-MIX ASPHALT SURFACE COURSE, MIX "D", N70	TON	13120	13120						
44000158	HOT-MIX ASPHALT SURFACE REMOVAL, 2 1/4"	SQ YD	156,273	156,273						
44002224	HOT-MIX ASPHALT REMOVAL OVER PATCHES, 6"	SQ YD	7,938	7,938						
44201765	CLASS D PATCHES, TYPE II, 10 INCH	SQ YD	3,907	3,907						
44201769	CLASS D PATCHES, TYPE III, 10 INCH	SQ YD	2,345	2,345						
44201771	CLASS D PATCHES, TYPE IV, 10 INCH	SQ YD	1,563	1,563						
48101200	AGGREGATE SHOULDERS, TYPE B	TON	1884	1884						
58700300	CONCRETE SEALER	SQ FT	7360	7360						
60300305	FRAMES AND LIDS TO BE ADJUSTED	EACH	50	50						
*63000000	STEEL PLATE BEAM GUARD RAIL, TYPE A	FOOT	220	220						
*63100167	TRAFFIC BARRIER TERMINAL TYPE I, SPECIAL (TANGENT)	EACH	4	4						
63200310	GUARDRAIL REMOVAL	FOOT	220	220						
67000400	ENGINEER'S FIELD OFFICE, TYPE A	CAL MO	3	3						
67100100	MOBILIZATION	L SUM	1	1						
70102625	TRAFFIC CONTROL AND PROTECTION, STANDARD 701606	L SUM	1	1						

SUMMARY OF QUANTITIES			CONSTRUCTION TYPE CODE							
CODE NO	ITEM	UNIT	URBAN TOTAL QUANTITIES 100% STATE							
				I000-2A	BRIDGE REPAIR SFTY-2A					
70102635	TRAFFIC CONTROL AND PROTECTION, STANDARD 701701	L SUM	1	1						
70300100	SHORT-TERM PAVEMENT MARKING	FOOT	13389	13389						
70300210	TEMPORARY PAVEMENT MARKING - LETTERS AND SYMBOLS	SQ FT	1570	1570						
70300220	TEMPORARY PAVEMENT MARKING - LINE 4"	FOOT	108025	108025						
70300240	TEMPORARY PAVEMENT MARKING - LINE 6"	FOOT	5058	5058						
70300280	TEMPORARY PAVEMENT MARKING - LINE 24"	FOOT	132	132						
70301000	WORK ZONE PAVEMENT MARKING REMOVAL	SQ FT	44835	44835						
*78000100	THERMOPLASTIC PAVEMENT MARKING - LETTERS AND SYMBOLS	SQ FT	1570	1570						
*78000200	THERMOPLASTIC PAVEMENT MARKING - LINE 4"	FOOT	108025	108025						
*78000400	THERMOPLASTIC PAVEMENT MARKING - LINE 6"	FOOT	5058	5058						
*78000650	THERMOPLASTIC PAVEMENT MARKING - LINE 24"	FOOT	132	132						
*78100100	RAISED REFLECTIVE PAVEMENT MARKER	EACH	1470	1470						
*78200405	GUARDRAIL MARKERS	EACH	4	4						
*78201000	TERMINAL MARKER - DIRECT APPLIED	EACH	4	4						
78300200	RAISED REFLECTIVE PAVEMENT MARKER REMOVAL	EACH	1323	1323						
*88600600	DETECTOR LOOP REPLACEMENT	FOOT	490	490						
X0301424	SILICONE JOINT SEALER	FOOT	172						172	
X0322256	TEMPORARY INFORMATION SIGNING	SQ FT	51.4	51.4						
X0325303	STRUCTURAL REPAIR OF CONCRETE (DEPTH GREATER THAN 5 INCHES)	SQ FT	75						75	
X0325305	STRUCTURAL REPAIR OF CONCRETE (DEPTH EQUAL TO OR LESS THAN 5 INCHES)	SQ FT	40						40	
X0656100	DRIVEWAY PAVEMENT REMOVAL AND REPLACEMENT	SQ YD	1820	1820						
X4067107	POLYMERIZED LEVELING BINDER (MACHINE METHOD), IL-4.75, N50	TON	6154	6154						
Z0001800	APPROACH SLAB REPAIR (PARTIAL DEPTH)	SQ YD	2						2	

* SPECIALTY ITEMS

REVISIONS	
NAME	DATE

ILLINOIS DEPARTMENT OF TRANSPORTATION
SUMMARY OF QUANTITIES
F.A.P. RTE. 846/IL 53 (CHICAGO ST.)
MANHATTAN RD. TO OLD ELM RD.

3/10/2007 8:48:53 AM C:\PLOT\846-01020209.m32

F. A. P. DIST.	SECTION	COUNTY	TOTAL SHEETS	SHEET NO.
846	(4,4R,&5) RS-7	WILL	35	4
STA. +	TO STA. +			
FED. ROAD DIST. NO. 1	ILLINOIS	FED. AID PROJECT		

CONTRACT NO.: 62364

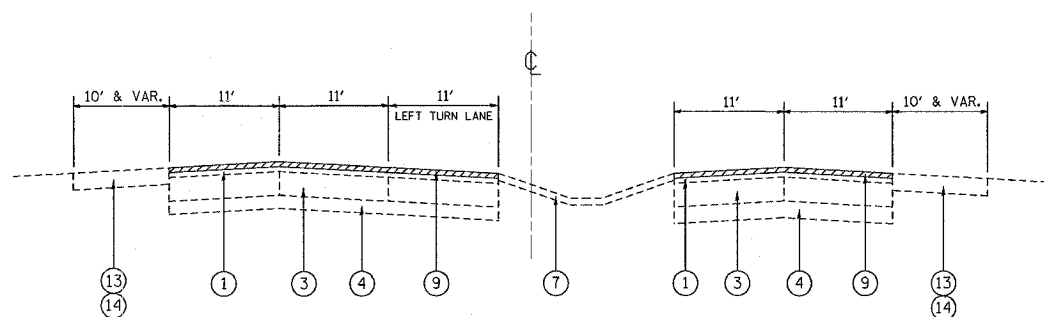

EXISTING TYPICAL CROSS SECTION

STA. 9+77 TO STA. 14+06
 STA. 117+34 TO STA. 119+60
 STA. 141+46 TO STA. 144+92
 STA. 193+20 TO STA. 196+98
 STA. 197+59 TO STA. 201+24
 STA. 202+84 TO STA. 205+63
 STA. 206+30 TO STA. 209+85
 STA. 211+15 TO STA. 214+07

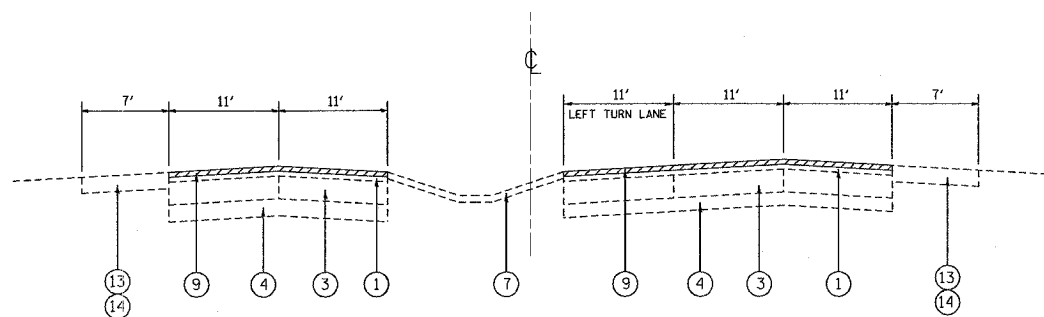

EXISTING TYPICAL CROSS SECTION

STA. 190+72 TO STA. 192+20

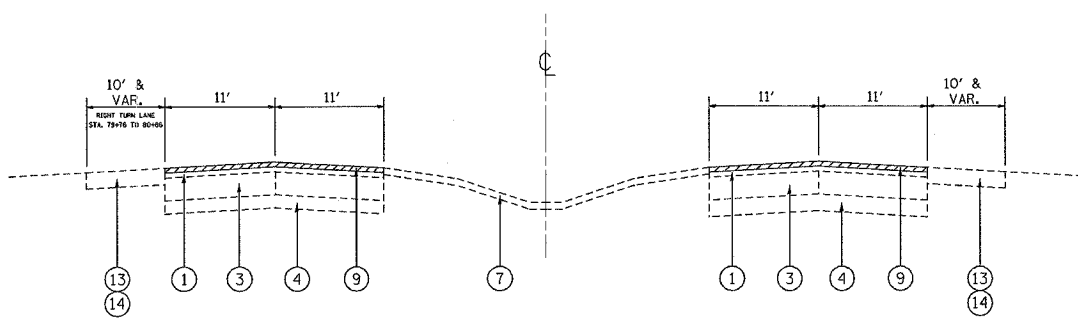

EXISTING TYPICAL CROSS SECTION

STA. 14+06 TO STA. 106+68
 STA. 119+60 TO STA. 140+65
 STA. 144+92 TO STA. 190+72
 STA. 214+91 TO STA. 244+09
 STA. 253+98 TO STA. 257+65

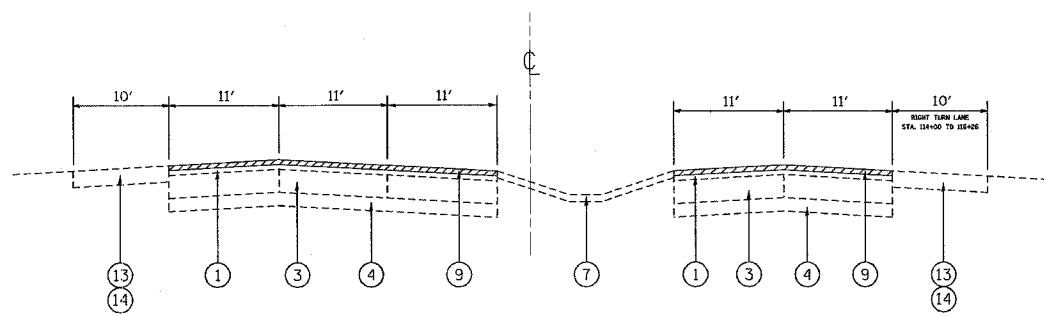

EXISTING TYPICAL CROSS SECTION

STA. 106+68 TO STA. 116+26

LEGEND:

- ① EXISTING HOT-MIX ASPHALT SURFACE, 3"
- ② EXISTING HOT-MIX ASPHALT SHOULDER, 8"
- ③ EXISTING P.C.C. PAVEMENT, 10"
- ④ EXISTING STABILIZED SUB-BASE
- ⑤ EXISTING COMBINATION CONCRETE CURB AND GUTTER, TYPE B-6.12
- ⑥ EXISTING COMBINATION CONCRETE CURB AND GUTTER, TYPE M-2.12
- ⑦ EXISTING GRASS MEDIAN
- ⑧ EXISTING HOT-MIX ASPHALT MEDIAN
- ⑨ PROPOSED HOT-MIX ASPHALT SURFACE REMOVAL, 2 1/4"
- ⑩ PROPOSED POLYMERIZED LEVELING BINDER (MACHINE METHOD), SUPERPAVE, IL-4.75, 3/4"
- ⑪ PROPOSED HOT-MIX ASPHALT SURFACE COURSE, SUPERPAVE, MIX "D", N70, 1 1/2"
- ⑫ PROPOSED HOT-MIX ASPHALT BINDER COURSE, IL-19.0, N70, 5 3/4"
- ⑬ PROPOSED GRADING AND SHAPING SHOULDERS
- ⑭ PROPOSED AGGREGATE SHOULDERS, TYPE B

MIXTURE REQUIREMENTS

MIXTURE USE	AC/PG	RAP % (MAX)	DESIGN AIR VOIDS
HOT-MIX ASPHALT SURFACE COURSE, SUPERPAVE, MIX "C", N50 IL-9.5MM	PG 64-22	15	4% @ 50
HOT-MIX ASPHALT SURFACE COURSE, SUPERPAVE, MIX "D", N70 IL-9.5MM	PG 64-22	10/15	4% @ 70
POLYMERIZED LEVELING BINDER (MACHINE METHOD), SUPERPAVE, IL-4.75, N50	SBS/SBR PG 76-28/ 76-22	15	4% @ 50
CLASS "D" PATCHES, 10" * BINDER COURSE, IL-19MM	PG 64-22/ 58-22	15/25	4% @ 70
HOT-MIX ASPHALT REPLACEMENT OVER PATCHES, BINDER COURSE, * IL-19MM	PG 64-22/ 58-22	15/25	4% @ 70

NOTES:

THE UNIT WEIGHT USED TO CALCULATE ALL HOT-MIX SURFACE QUANTITIES IS 112 LBS./ SQ. YD./ IN.

* WHEN RAP EXCEEDS 20% THE NEW ASPHALT BINDER IN THE MIX SHALL BE PG 58-22

REVISIONS	
NAME	DATE

ILLINOIS DEPARTMENT OF TRANSPORTATION
 TYPICAL SECTIONS
 F.A.P. 846/IL 53 (CHICAGO ST.)
 MANHATTAN RD. TO OLD ELM RD.

SCALE: VERT. 1"=50'
 HORIZ. 1"=50'
 DATE 5/11/2007

DRAWN BY: P. STEED
 CHECKED BY:

F. A. P. NO.	SECTION	COUNTY	TOTAL SHEETS	SHEET NO.
846	(4,4R,&5) RS-7	WILL	35	5
STA. +	TO STA. +			
FED. ROAD DIST. NO. 1	ILLINOIS	FED. AID PROJECT		

CONTRACT NO.: 62364

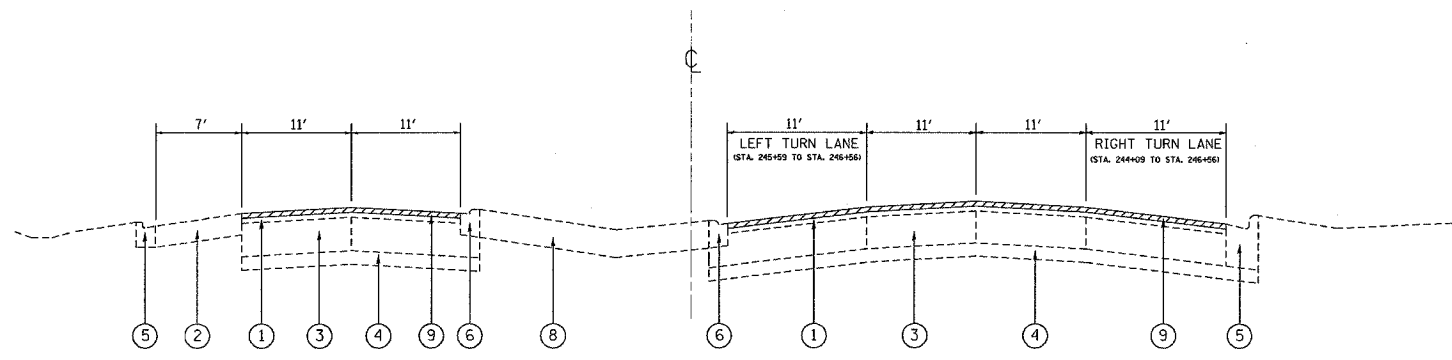

EXISTING TYPICAL CROSS SECTION
STA. 244+09 TO 246+95

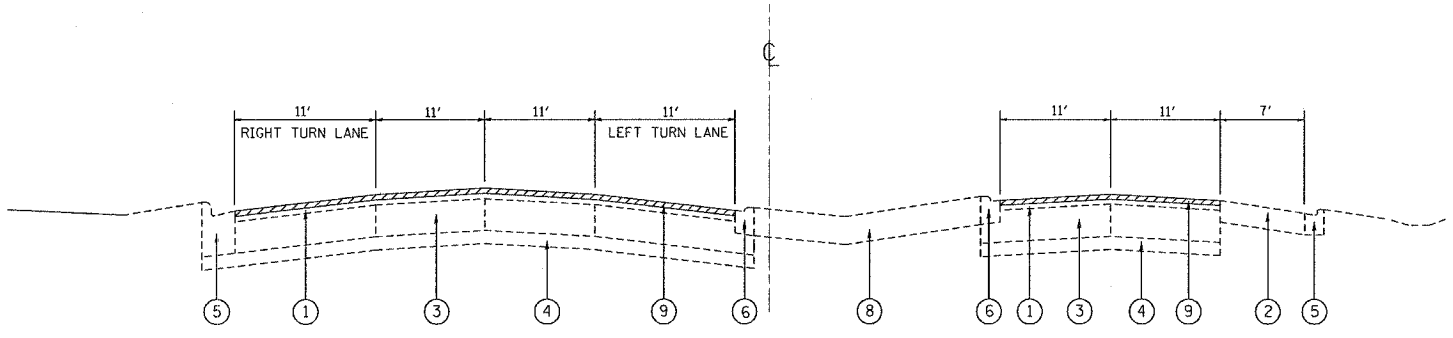

EXISTING TYPICAL CROSS SECTION
STA. 247+52 TO STA. 250+48

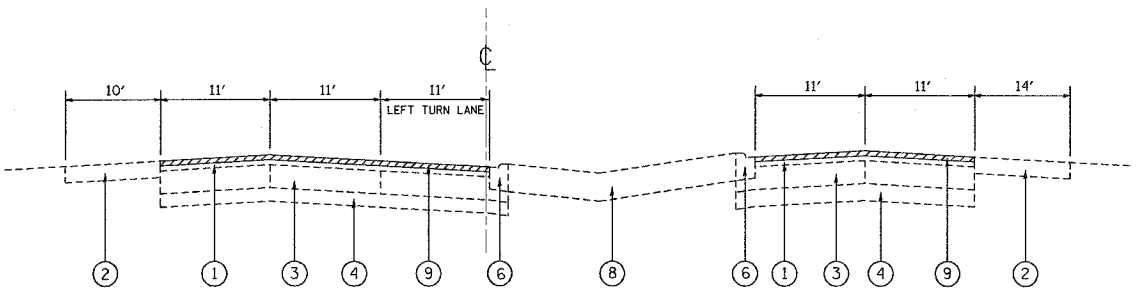

EXISTING TYPICAL CROSS SECTION
STA. 251+14 TO STA. 253+98
STA. 258+35 TO STA. 261+20

LEGEND:

- ① EXISTING HOT-MIX ASPHALT SURFACE, 3"
- ② EXISTING HOT-MIX ASPHALT SHOULDER, 8"
- ③ EXISTING P.C.C. PAVEMENT, 10"
- ④ EXISTING STABILIZED SUB-BASE
- ⑤ EXISTING COMBINATION CONCRETE CURB AND GUTTER, TYPE B-6.12
- ⑥ EXISTING COMBINATION CONCRETE CURB AND GUTTER, TYPE M-2.12
- ⑦ EXISTING GRASS MEDIAN
- ⑧ EXISTING HOT-MIX ASPHALT MEDIAN
- ⑨ PROPOSED HOT-MIX ASPHALT SURFACE REMOVAL, 2 1/4"
- ⑩ PROPOSED POLYMERIZED LEVELING BINDER (MACHINE METHOD), SUPERPAVE, IL-4.75, 3/4"
- ⑪ PROPOSED HOT-MIX ASPHALT SURFACE COURSE, SUPERPAVE, MIX "D", N70, 1 1/2"
- ⑫ PROPOSED HOT-MIX ASPHALT BINDER COURSE, IL-19.0, N70, 5 3/4"
- ⑬ PROPOSED GRADING AND SHAPING SHOULDERS
- ⑭ PROPOSED AGGREGATE SHOULDERS, TYPE B

5/2/2007
c:\p\project\846\002020\01002020\0032
REF

REVISIONS	
NAME	DATE

ILLINOIS DEPARTMENT OF TRANSPORTATION
TYPICAL SECTIONS
F.A.P. 846/IL 53 (CHICAGO ST.)
MANHATTAN RD. TO OLD ELM RD.

SCALE: VERT. 1"=50'
HORIZ. 1"=50'
DATE 5/2/2007

DRAWN BY: P. STEED
CHECKED BY:

F. A. P. NO.	SECTION	COUNTY	TOTAL SHEETS	SHEET NO.
846	(4,4R,&5) RS-7	WILL	35	6
STA. +	TO STA. +			
FED. ROAD DIST. NO. 1	BILLINGS	FED. AID PROJECT		

CONTRACT NO.: 62364

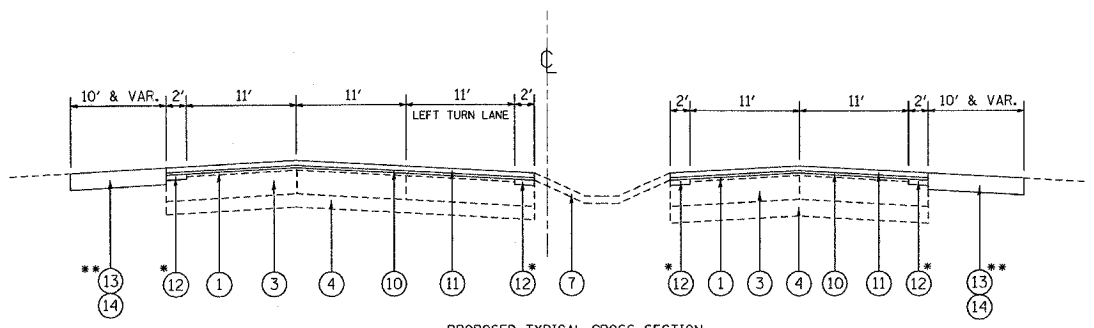

PROPOSED TYPICAL CROSS SECTION
 STA. 9+77 TO STA. 14+06
 STA. 117+34 TO STA. 119+60
 STA. 141+46 TO STA. 144+92
 STA. 193+20 TO STA. 196+98
 STA. 197+59 TO STA. 201+24
 STA. 202+84 TO STA. 205+63
 STA. 206+30 TO STA. 209+85
 STA. 211+15 TO STA. 214+07

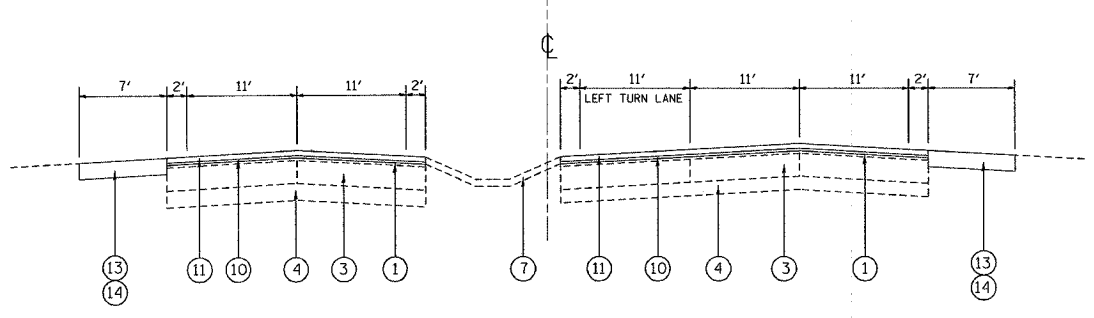

PROPOSED TYPICAL CROSS SECTION
 STA. 190+72 TO STA. 192+20

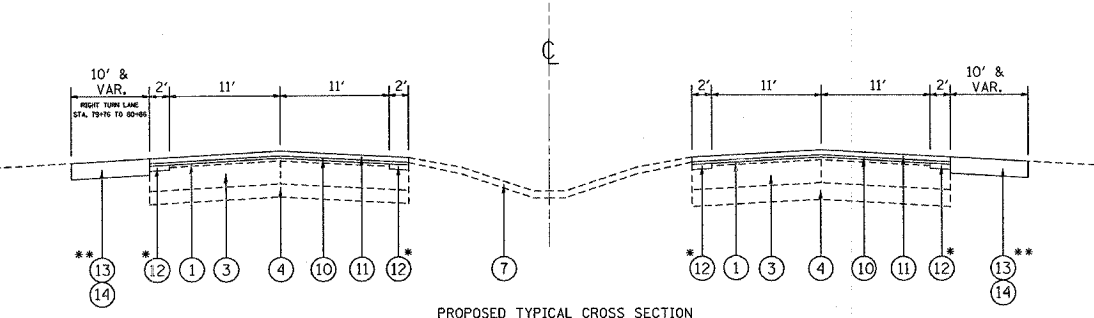

PROPOSED TYPICAL CROSS SECTION
 STA. 14+06 TO STA. 106+68
 STA. 119+60 TO STA. 140+65
 STA. 144+92 TO STA. 190+72
 STA. 214+91 TO STA. 244+09
 STA. 253+98 TO STA. 257+65

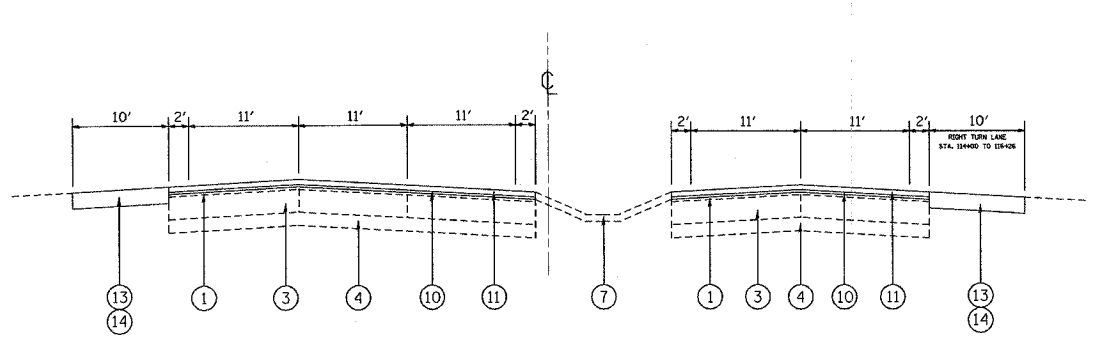

PROPOSED TYPICAL CROSS SECTION
 STA. 106+68 TO STA. 116+26

LEGEND:

- ① EXISTING HOT-MIX ASPHALT SURFACE, 3"
- ② EXISTING HOT-MIX ASPHALT SHOULDER, 8"
- ③ EXISTING P.C.C. PAVEMENT, 10"
- ④ EXISTING STABILIZED SUB-BASE
- ⑤ EXISTING COMBINATION CONCRETE CURB AND GUTTER, TYPE B-6.12
- ⑥ EXISTING COMBINATION CONCRETE CURB AND GUTTER, TYPE M-2.12
- ⑦ EXISTING GRASS MEDIAN
- ⑧ EXISTING HOT-MIX ASPHALT MEDIAN
- ⑨ PROPOSED HOT-MIX ASPHALT SURFACE REMOVAL, 2 1/4"
- ⑩ PROPOSED POLYMERIZED LEVELING BINDER (MACHINE METHOD), SUPERPAVE, IL-4.75, 3/4"
- ⑪ PROPOSED HOT-MIX ASPHALT SURFACE COURSE, SUPERPAVE, MIX "D", N70, 1 1/2"
- ⑫ PROPOSED HOT-MIX ASPHALT BINDER COURSE, IL-19.0, N70, 5 3/4"
- ⑬ PROPOSED GRADING AND SHAPING SHOULDERS
- ⑭ PROPOSED AGGREGATE SHOULDERS, TYPE B

NOTE:

- * PROP. HOT-MIX ASPHALT BINDER COURSE WILL BE ADDED FROM STA. 62+22 TO STA. 141+90 FOR SHOULDER STRIP REPAIR
- ** PROPOSED HOT-MIX ASPHALT SHOULDER RESURFACING FROM STA. 244+09 TO 261+20

REVISIONS	
NAME	DATE

ILLINOIS DEPARTMENT OF TRANSPORTATION
 TYPICAL SECTION
 F.A.P. 846/IL 53 (CHICAGO ST.)
 MANHATTAN RD. TO OLD ELM RD.
 SCALE: VERT. 1"=50'
 HORIZ. 1"=50'
 DATE 5/2/2007
 DRAWN BY: P. STEED
 CHECKED BY:

5/2/2007
 C:\p\objects\846\1002028\1002020a.mxd
 REF-
 REF-

F. A. P. NO.	SECTION	COUNTY	TOTAL SHEETS	SHEET NO.
846	(4,4R,&5)RS-7	WILL	35	8
STA. 9+77	TO STA. 30+00			
FED. ROAD DIST. NO. 1	BALDWIN	FED. AID PROJECT		

CONTRACT NO.: 62364

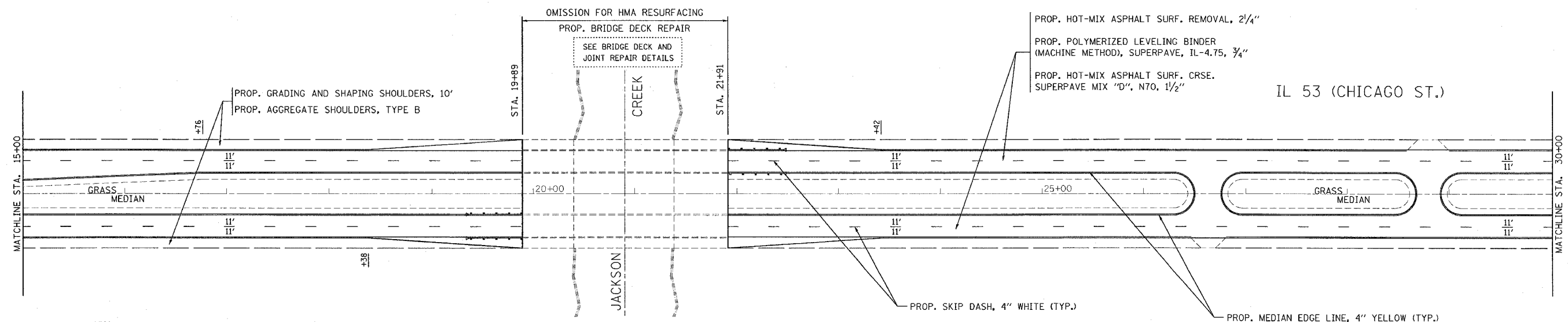
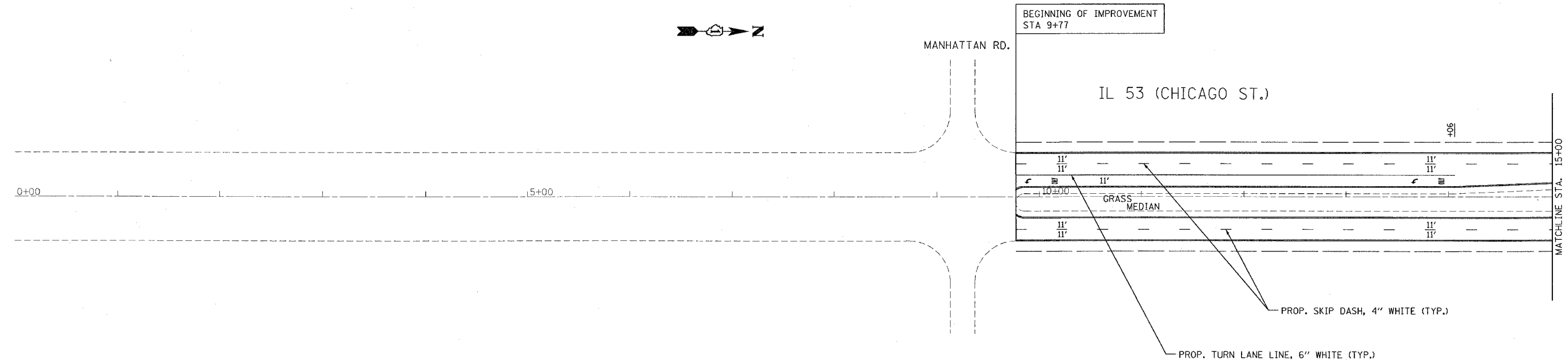

NOTES:

PERMANENT PAVEMENT MARKINGS SHALL BE THERMOPLASTIC (OF THE EXTRUDED TYPE) AND SHOULD BE PLACED IN ACCORDANCE WITH "DISTRICT ONE TYPICAL PAVEMENT MARKINGS" DETAIL. (TC-13)

RAISED REFLECTIVE PAVEMENT MARKERS SHALL BE IN ACCORDANCE WITH THE DISTRICT ONE "TYPICAL APPLICATION RAISED REFLECTIVE PAVEMENT MARKERS" DETAIL."

THE RESIDENT ENGINEER SHOULD CONTACT MS. CORA MATHIS, AREA TRAFFIC ENGINEER, AT (815) 485-6475 PRIOR TO PLACING ANY PAVEMENT MARKINGS.

REVISIONS	
NAME	DATE

ILLINOIS DEPARTMENT OF TRANSPORTATION
 F.A.P. 846/IL 53 (CHICAGO ST.)
 MANHATTAN RD. TO OLD ELM RD.
 ROADWAY AND PAVEMENT MARKING PLAN
 SCALE: VERT. 1"=50'
 HORIZ. 1"=50'
 DATE 3/20/2007
 DRAWN BY: P. STEED
 CHECKED BY:

F. A. P. NO.	SECTION	COUNTY	TOTAL SHEETS	SHEET NO.
846	(4,4R,&5)RS-7	WILL	35	11
STA. 90+00	TO STA. 120+00			
FED. ROAD DIST. NO. 1	ILLINOIS	FED. AID PROJECT		

CONTRACT NO.: 62364

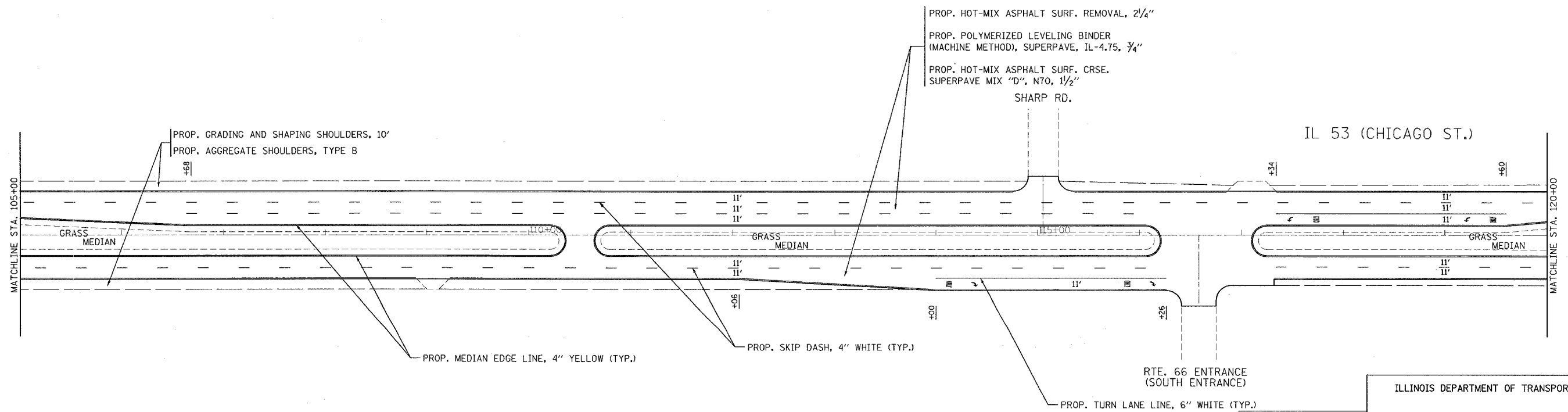
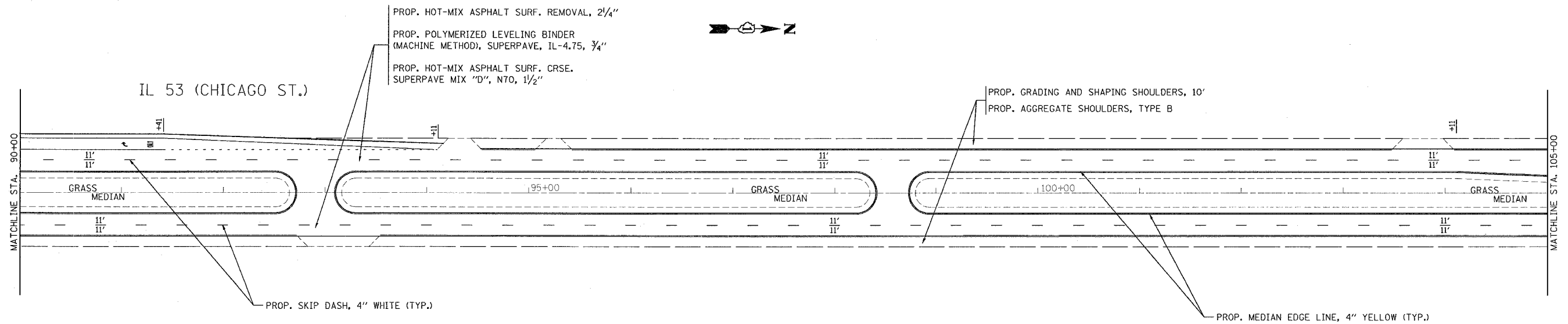

REVISIONS	
NAME	DATE

ILLINOIS DEPARTMENT OF TRANSPORTATION
 F.A.P. 846/IL 53 (CHICAGO ST.)
 MANHATTAN RD. TO OLD ELM RD.
 ROADWAY AND PAVEMENT MARKING PLAN
 SCALE: VERT. 1"=50'
 HORIZ. 1"=50'
 DATE 3/20/2007
 DRAWN BY: P. STEED
 CHECKED BY:

3/20/2007
 c:\projects\846\102028\102028.dwg
 *REF-
 *REF-
 *REF-

VI=

F. A. P. NO.	SECTION	COUNTY	TOTAL SHEETS	SHEET NO.
846	(4,4R.&S)RS-7	WILL	35	12
STA. 120+00		TO STA. 150+00		
FED. ROAD DIST. NO. 1		ILLINOIS	FED. AID PROJECT	

CONTRACT NO.: 62364

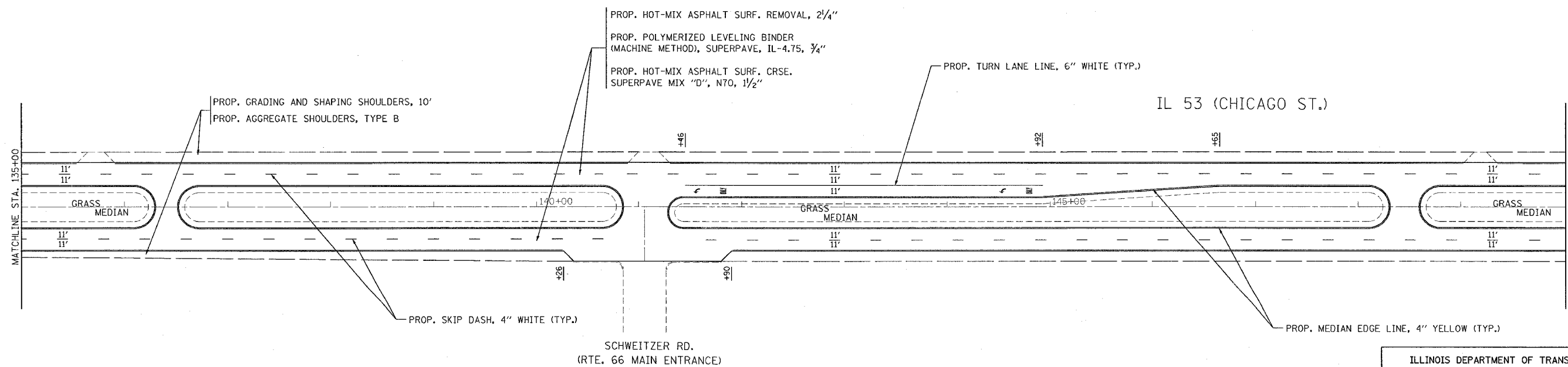
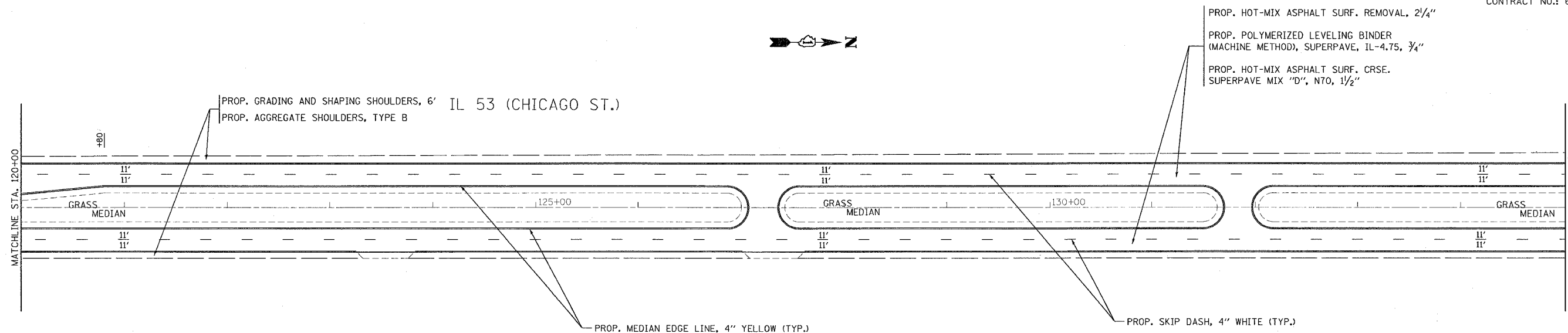

REVISIONS	
NAME	DATE

ILLINOIS DEPARTMENT OF TRANSPORTATION

F.A.P. 846/IL 53 (CHICAGO ST.)
MANHATTAN RD. TO OLD ELM RD.
ROADWAY AND PAVEMENT MARKING PLAN

SCALE: VERT. 1"=50'
HORIZ. 1"=50'

DATE 3/20/2007

DRAWN BY: P. STEED
CHECKED BY:

3/20/2007
C:\p\projects\846\1020202\000.mxd
REF

F.A.P. NO.	SECTION	COUNTY	TOTAL SHEETS	SHEET NO.
846	(4,4R,&S)RS-7	WILL	35	13
STA. 150+00		TO STA. 180+00		
FED. ROAD DIST. NO. 1	ILLINOIS	FED. AID PROJECT		

CONTRACT NO.: 62364

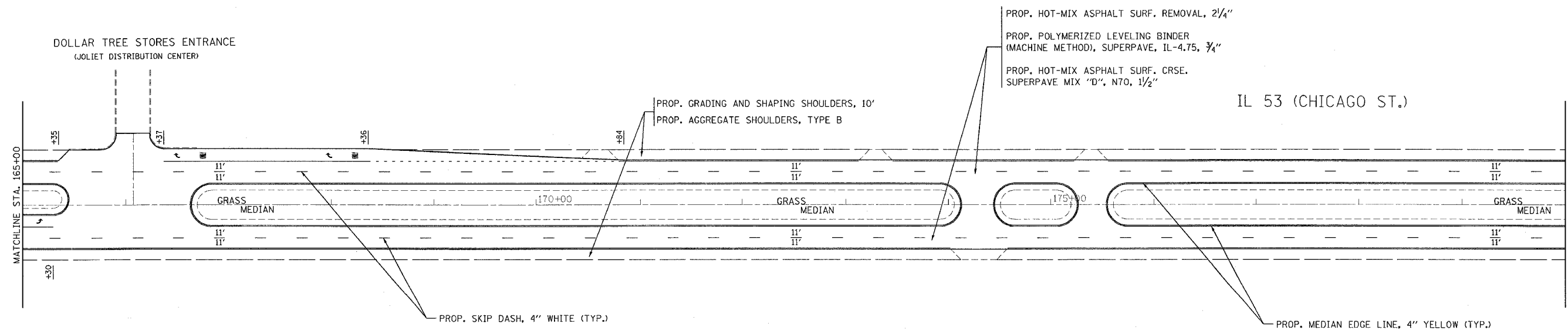
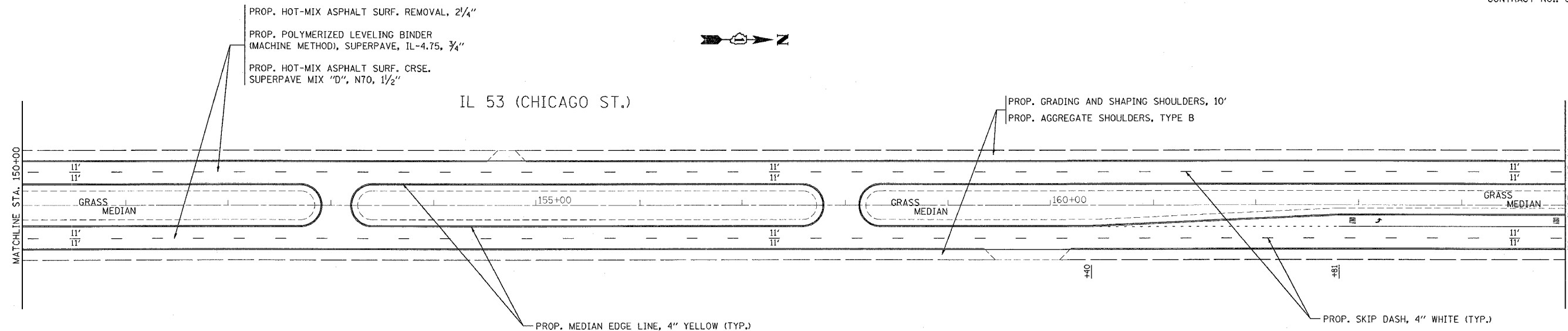

3/20/2007
 c:\p\projects\846\100202\ref\00202ecum32
 REF

REVISIONS	
NAME	DATE

ILLINOIS DEPARTMENT OF TRANSPORTATION
 F.A.P. 846/IL 53 (CHICAGO ST.)
 MANHATTAN RD. TO OLD ELM RD.
 ROADWAY AND PAVEMENT MARKING PLAN
 SCALE: VERT. 1"=50'
 HORIZ. 1"=50'
 DATE 3/20/2007
 DRAWN BY: P. STEED
 CHECKED BY:

F. A. P. NO.	SECTION	COUNTY	TOTAL SHEETS	SHEET NO.
846	(4,4R,&5)RS-7	WILL	35	14
STA. 180+00		TO STA. 210+00		
FED. ROAD DIST. NO. 1		ILLINOIS	FED. AID PROJECT	
CONTRACT NO.: 62364				

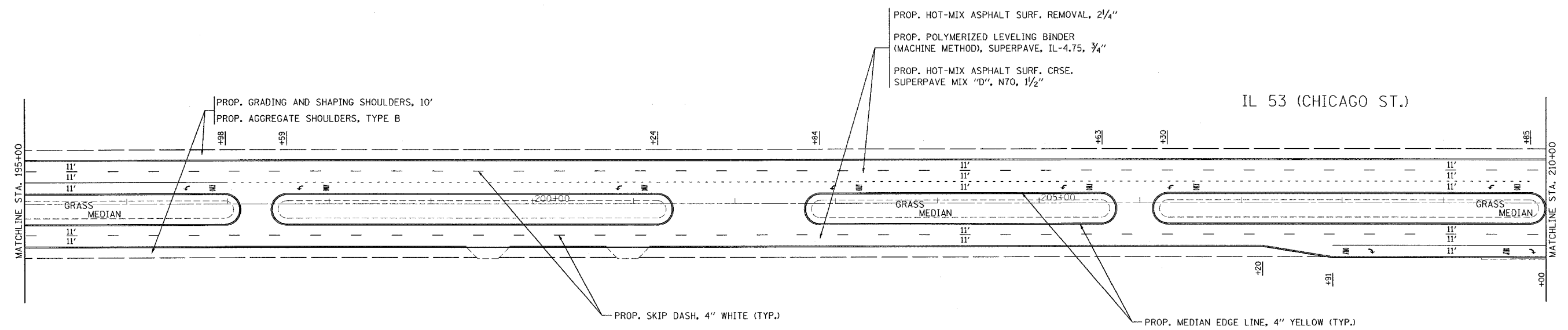
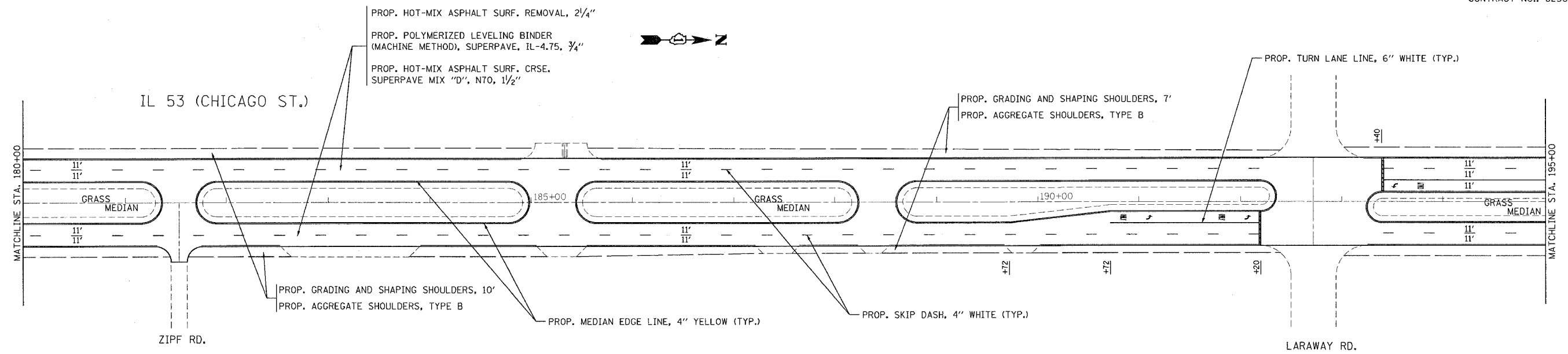

REVISIONS	
NAME	DATE

ILLINOIS DEPARTMENT OF TRANSPORTATION
 F.A.P. 846/IL 53 (CHICAGO ST.)
 MANHATTAN RD. TO OLD ELM RD.
 ROADWAY AND PAVEMENT MARKING PLAN
 SCALE: VERT. 1"=50'
 HORIZ. 1"=50'
 DATE 3/26/2007
 DRAWN BY: P. STEED
 CHECKED BY:

3/26/2007
 c:\p\proj\sect\sb\d1002028\d1002020a.mxd
 REF
 VI=

F. A. P. NO.	SECTION	COUNTY	TOTAL SHEETS	SHEET NO.
846	(4,4R,85)RS-7	WILL	35	15
STA. 210+00	TO STA. 240+00			
FED. ROAD DIST. NO. 1	ELMERS	FED. AID PROJECT		

CONTRACT NO.: 62364

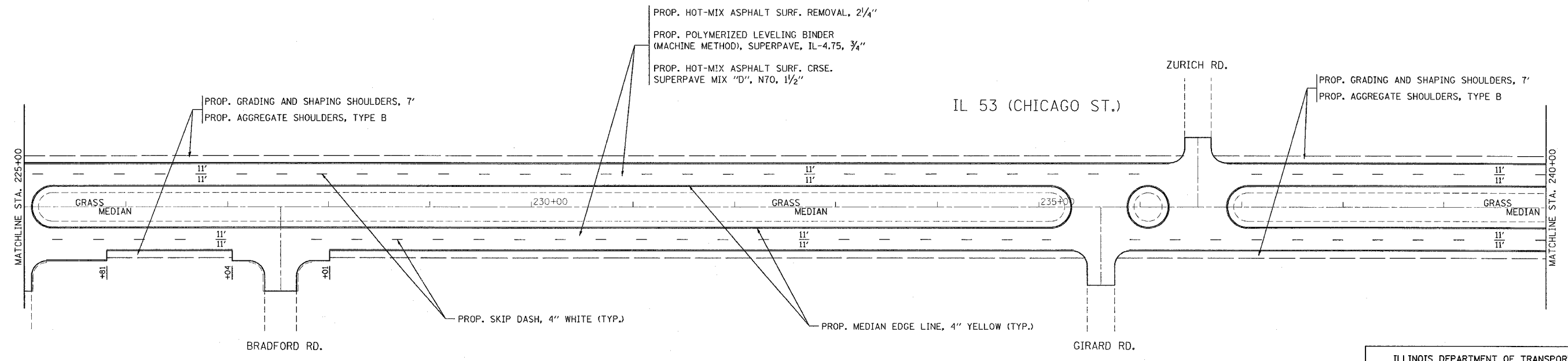
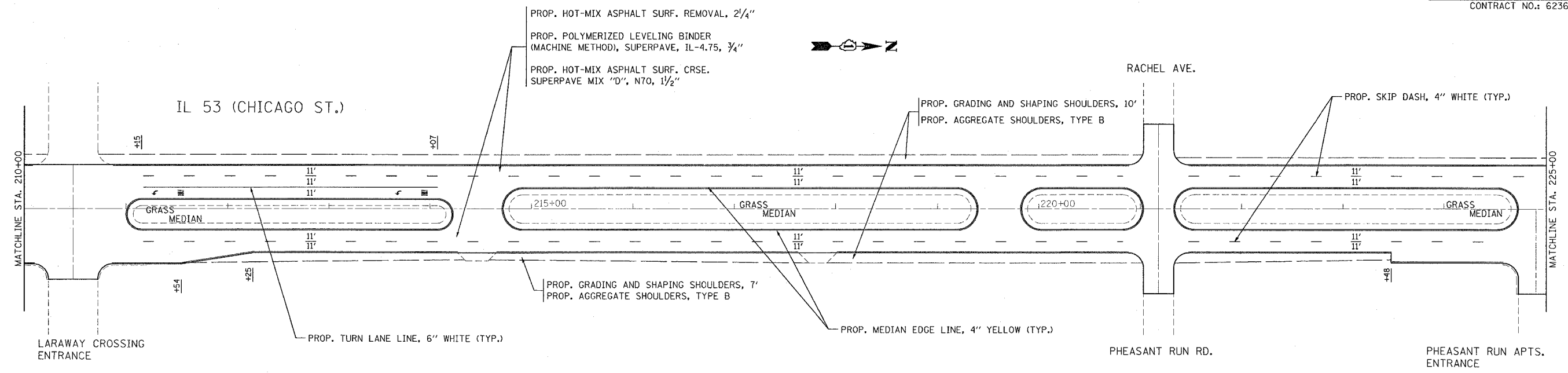

REVISIONS	
NAME	DATE

ILLINOIS DEPARTMENT OF TRANSPORTATION
 F.A.P. 846/IL 53 (CHICAGO ST.)
 MANHATTAN RD. TO OLD ELM RD.
 ROADWAY AND PAVEMENT MARKING PLAN
 SCALE: VERT. 1"=50'
 HORIZ. 1"=50'
 DATE 3/20/2007
 DRAWN BY: P. STEED
 CHECKED BY:

3/20/2007
 c:\projects\846\846.dwg
 REF-
 REF-

F.A.P. NO.	SECTION	COUNTY	TOTAL SHEETS	SHEET NO.
846	(4,4R,85)RS-7	WILL	35	16
STA. 240+00	TO STA. 261+20			
FED. ROAD DIST. NO. 1	BLINDS	FED. AID PROJECT		

CONTRACT NO.: 62364

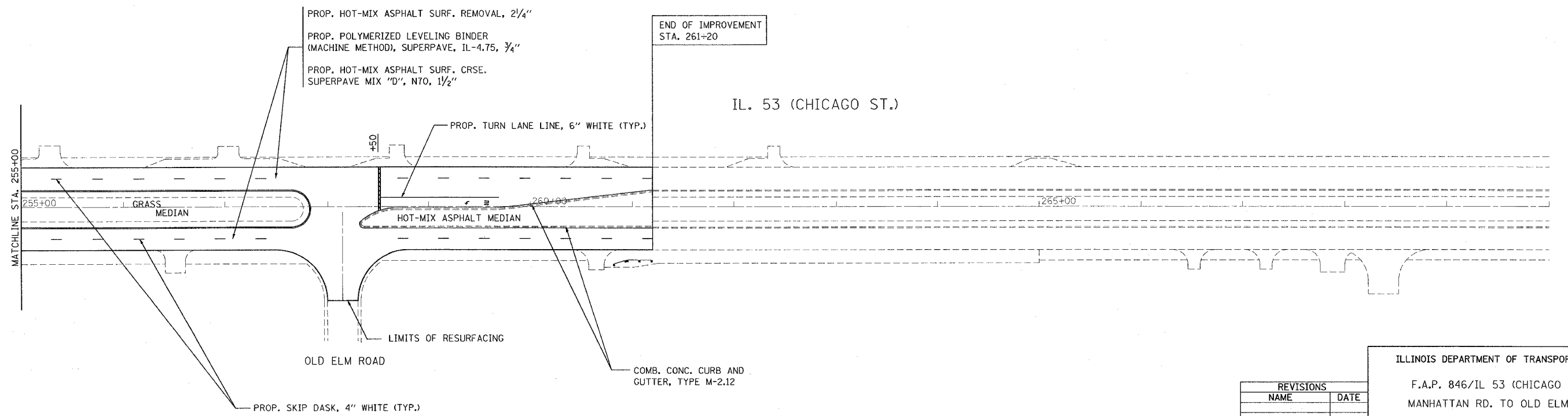
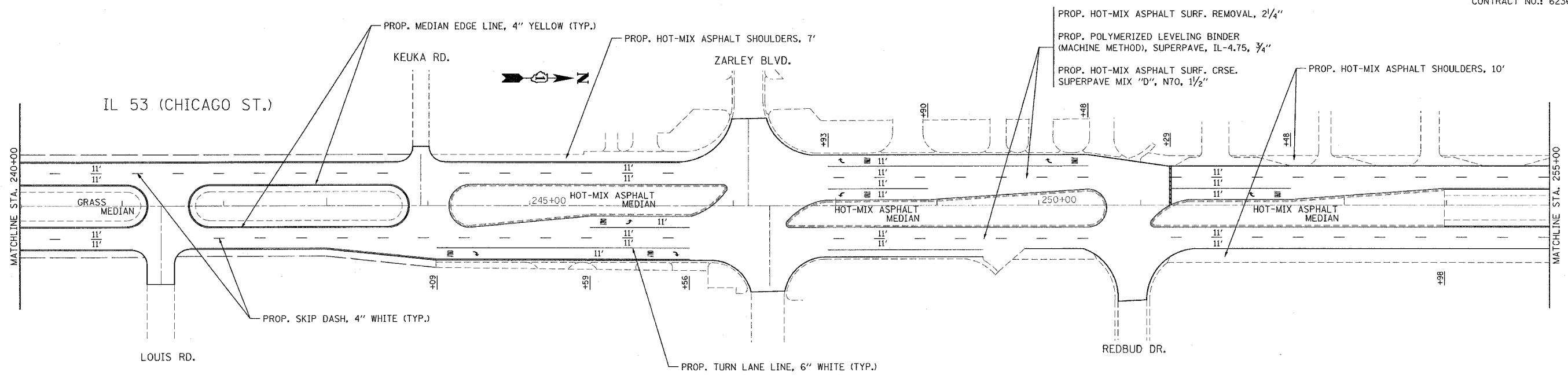

REVISIONS	
NAME	DATE

ILLINOIS DEPARTMENT OF TRANSPORTATION

F.A.P. 846/IL 53 (CHICAGO ST.)
 MANHATTAN RD. TO OLD ELM RD.
 ROADWAY AND PAVEMENT MARKING PLAN

VERT. SCALE: 1"=50'
 HORIZ. SCALE: 1"=50'
 DATE: 3/20/2007

DRAWN BY: P. STEED
 CHECKED BY:

3/20/2007
 c:\p\projects\846\100202\dl1002020am.m32
 REF

F.A.P. RTE.	SECTION	COUNTY	TOTAL SHEETS	SHEET NO.
846	(4,4R,&5) RS-7	WILL	35	17
STA.	TO STA.			
FED. ROAD DIST. NO. 1	ILLINOIS	FED. AID PROJECT		
CONTRACT NO. 62364				

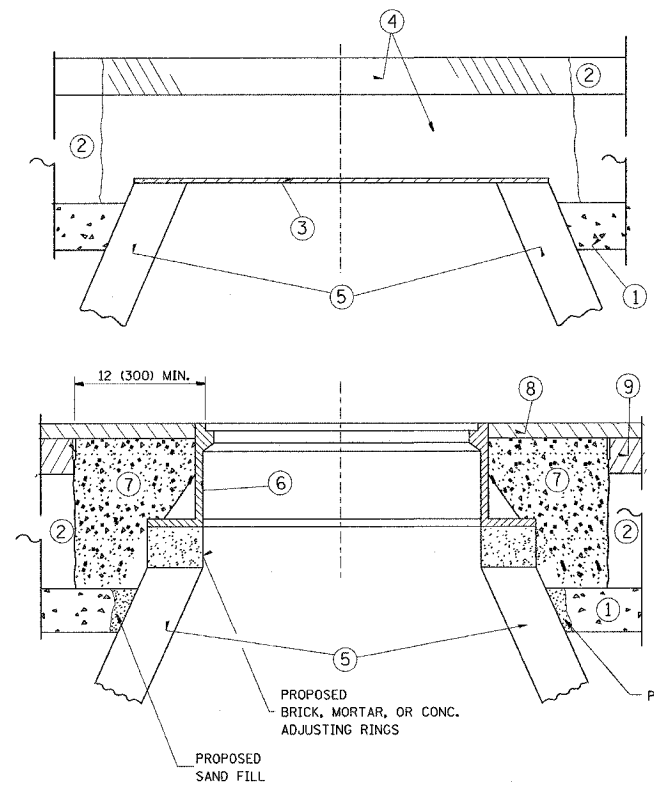

CONSTRUCTION PROCEDURES

STAGE 1 (BEFORE PAVEMENT MILLING)

- A) REMOVE A MINIMUM OF 12 (300) OF THE PAVEMENT FROM AROUND THE STRUCTURE.
- B) REMOVE THE EXISTING FRAME AND LID FROM THE STRUCTURE.
- C) COVER THE STRUCTURE OPENING WITH A 36 (900) DIAMETER METAL PLATE.
- D) BACKFILL WITH CRUSHED STONE AND A MINIMUM 1 1/2 (40) THICK HMA SURFACE MIX APPROVED BY THE ENGINEER.

STAGE 2 (AFTER PAVEMENT MILLING)

- A) REMOVE THE HMA SURFACE MIX AND CRUSHED STONE.
- B) INSTALL THE FRAME AND LID; ADJUST THE FRAME TO ITS FINAL SURFACE ELEVATION.
- C) THE SURROUNDING SPACE SHALL BE FILLED WITH CLASS SI CONCRETE, OR HMA SURFACE COURSE OR HMA BINDER COURSE TO THE ELEVATION OF THE SURFACE OF THE EXISTING BASE COURSE OR THE BINDER COURSE.

THE PROCEDURE EXPLAINED ABOVE SHALL CONFORM TO THE APPLICABLE PORTIONS OF SECTIONS 353, 406, 602, AND 603 OF THE STANDARD SPECIFICATIONS.

LEGEND

- ① SUB-BASE GRANULAR MATERIAL
- ② EXISTING PAVEMENT
- ③ 36 (900) DIAMETER METAL PLATE
- ④ PROPOSED CRUSHED STONE AND HMA SURFACE MIX
- ⑤ EXISTING STRUCTURE
- ⑥ FRAME AND LID (SEE NOTES)
- ⑦ CLASS SI CONCRETE, HMA SURFACE COURSE OR HMA BINDER COURSE
- ⑧ PROPOSED HMA SURFACE COURSE
- ⑨ PROPOSED HMA BINDER COURSE

LOCATION OF STRUCTURES:

THE CONTRACTOR WILL BE REQUIRED TO KEEP A RECORD OF THE LOCATIONS OF THE BURIED STRUCTURES ACCORDING TO THE STATION AND DISTANCE LEFT OR RIGHT OF THE CENTERLINE OF PAVEMENT. UPON COMPLETION OF THE WORK, THE CONTRACTOR WILL DELIVER THE RECORD TO THE ENGINEER.

BASIS OF PAYMENT: THIS WORK WILL BE PAID FOR AT THE CONTRACT UNIT PRICE PER EACH FOR "FRAMES AND LIDS TO BE ADJUSTED, SPECIAL"

NEW FRAMES AND LIDS, WHEN SPECIFIED, WILL BE PAID FOR SEPARATELY.

NOTES:

EXISTING BROKEN FRAMES AND LIDS SHALL BE REMOVED AND DISPOSED OF BY THE CONTRACTOR AND SHALL BE REPLACED AS DIRECTED BY THE ENGINEER. REPLACEMENT FRAMES AND LIDS WILL BE PAID FOR IN ACCORDANCE WITH ARTICLE 109.04 OF THE STANDARD SPECIFICATIONS UNLESS A SEPARATE PAY ITEM HAS BEEN PROVIDED.

IF THE EXISTING LIDS ARE OPEN, THE FRAME WILL BE ADJUSTED TO THE ELEVATION OF THE MILLED PAVEMENT SURFACE PRIOR TO THE MILLING OPERATION. THE FRAME WILL NOT BE REMOVED AND COVERED BY THE METAL PLATE.

CITY OF CHICAGO CASTINGS ARE THE PROPERTY OF THE CITY AND THE CONTRACTOR SHALL NOTIFY THE CITY FOR REMOVAL AND DISPOSITION OF THE CASTINGS.

THE METAL PLATE USED TO COVER THE STRUCTURE SHALL REMAIN THE PROPERTY OF THE CONTRACTOR.

WHEN STRUCTURES ARE TO BE ADJUSTED OR RECONSTRUCTED, THE LOWERING AND RAISING OF THE FRAMES AND LIDS WILL NOT BE PAID FOR SEPARATELY BUT WILL BE INCLUDED IN THE COST OF THE CORRESPONDING PAY ITEM.

DETAILS FOR FRAMES AND LIDS ADJUSTMENT WITH MILLING

ALL DIMENSIONS ARE IN INCHES (MILLIMETERS) UNLESS OTHERWISE SHOWN

REVISIONS	
NAME	DATE
R. SHAH	10/25/94
R. SHAH	01/30/95
R. SHAH	03/10/95
A. ABBAS	03/21/97
R. WIEDEMAN	05/14/04
R. BORO	01/01/07

ILLINOIS DEPARTMENT OF TRANSPORTATION
DETAILS FOR
FRAMES AND LIDS ADJUSTMENT
WITH MILLING

SCALE: VERT. NONE
HORIZ. NONE
PLOT DATE: 3/20/2007

DRAWN BY
CHECKED BY
BD600-03 (BD-8)
REVISION DATE: 01/01/07

PLOT DATE = 3/20/2007
PLOT SCALE = 50.000 / IN.
UBER NAME = stwdfps

F.A.P. RTE.	SECTION	COUNTY	TOTAL SHEETS	SHEET NO.
B46	(4,4R.&5)RS-7	WILL	35	18
STA.	TO STA.			
FED. ROAD DIST. NO. 1	ILLINOIS	FED. AID PROJECT		

CONTRACT NO. 62364

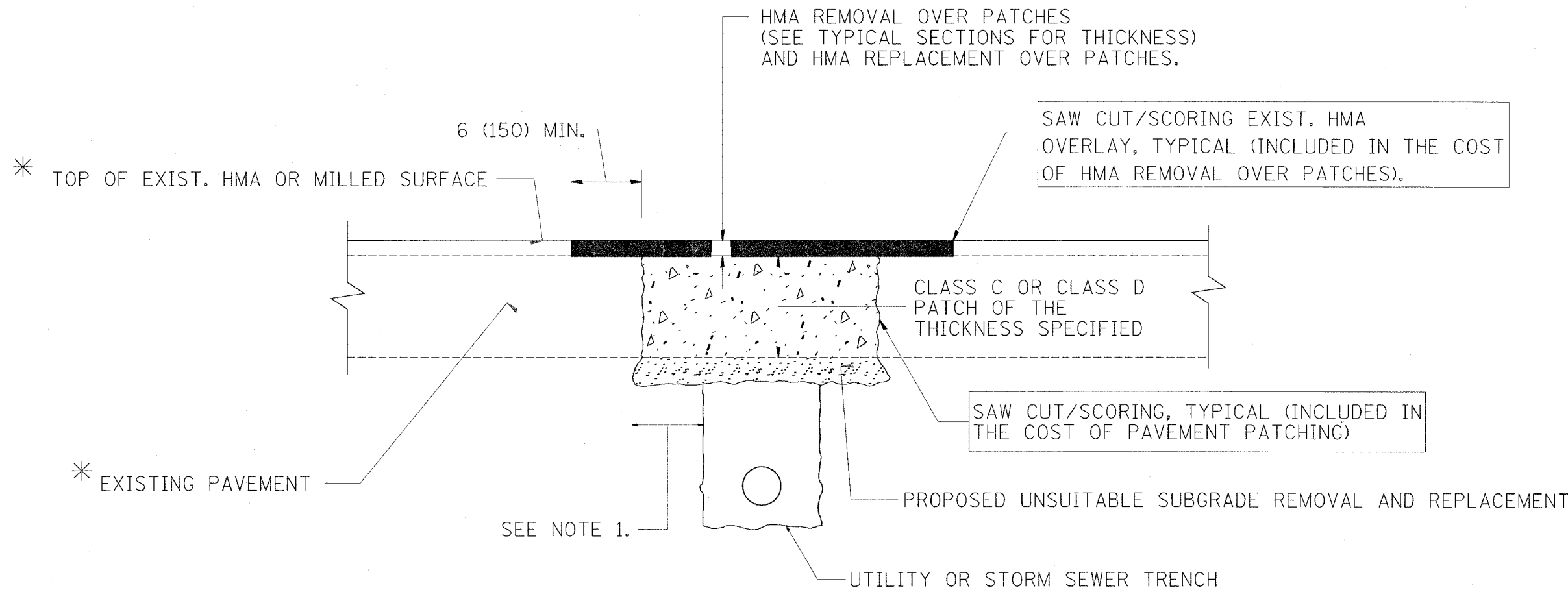

* SEE TYPICAL SECTIONS FOR THICKNESS AND MATERIALS

NOTES:

1. THE WIDTH OF THE FULL DEPTH PATCH OVER A TRENCH SHALL BE 12 (300) WIDER ON EACH SIDE OF THE TRENCH.
2. FOR METHOD OF MEASUREMENT AND BASIS OF PAYMENT, SEE RECURRING SPECIAL PROVISION "PATCHING WITH HOT-MIX ASPHALT OVERLAY REMOVAL".

SEQUENCE OF CONSTRUCTION

1. REMOVE THE EXISTING HMA MATERIAL OVER THE AREA TO BE PATCHED.
2. REMOVE AND REPLACE FULL DEPTH PATCHES
3. REPLACE HMA MATERIAL OVER THE AREA TO BE PATCHED.

ALL DIMENSIONS ARE IN INCHES (MILLIMETERS) UNLESS OTHERWISE SHOWN.

REVISIONS	
NAME	DATE
R. SHAH	10/25/94
R. SHAH	01/14/95
R. SHAH	03/23/95
R. SHAH	04/24/95
A. HOUSEH	03/15/96
A. ABBAS	03/21/97
A. ABBAS	01/20/98
ART ABBAS	04/27/98
R. BORO	01/01/07

ILLINOIS DEPARTMENT OF TRANSPORTATION

PAVEMENT PATCHING FOR HMA SURFACED PAVEMENT

SCALE: VERT. NONE
HORIZ. NONE

PLOT DATE: 3/20/2007

DRAWN BY
CHECKED BY
BD400-04 (BD-22)
REVISION DATE: 01/01/07

PLOT DATE = 3/20/2007
PLOT NAME = I:\PROJECTS\62364\62364.dwg
PLOT SCALE = 50.000' / IN.
USER NAME = standpa

F.A.P. RTE.	SECTION	COUNTY	TOTAL SHEETS	SHEET NO.
846	(4,4R,&5)RS-7	WILL	35	19
STA.		TO STA.		
FED. ROAD DIST. NO. 1 ILLINOIS FED. AID PROJECT				

CONTRACT NO. 62364

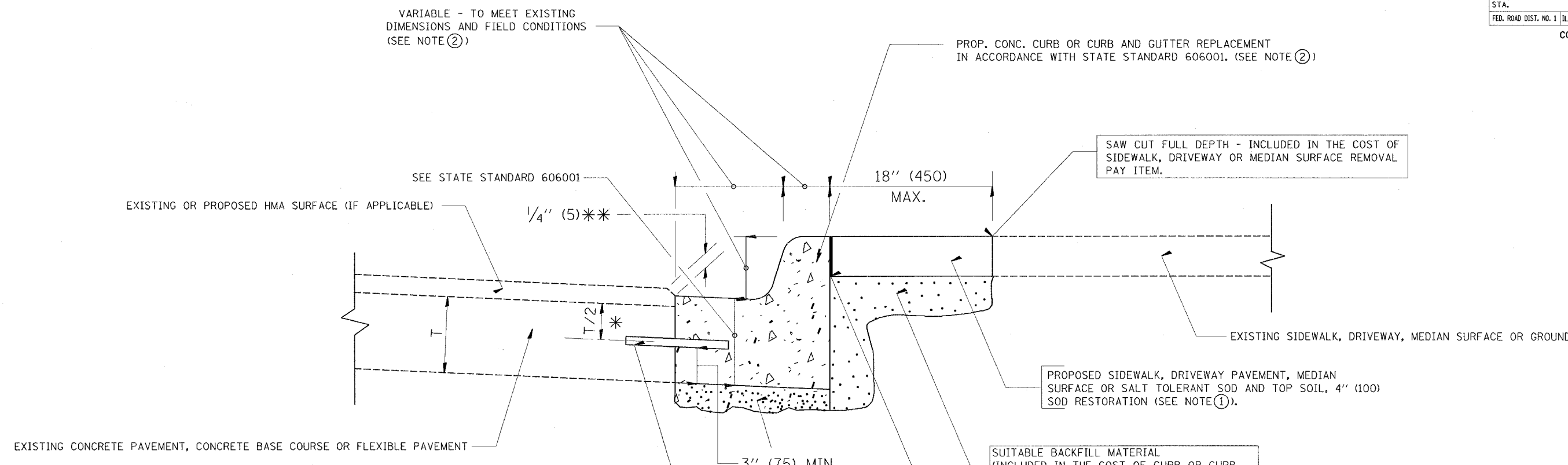

- * 3" (75) MINIMUM FROM TOP AND BOTTOM OF THE CONCRETE PAVEMENT OR BASE COURSE.
- * * IF THE FINAL SURFACE OF THE PAVEMENT IS CONCRETE, THE GUTTER IS TO BE FLUSH WITH THE PAVEMENT.

NOTE: ① SIDEWALK, DRIVEWAY PAVEMENT OR MEDIAN SURFACE SHALL BE SIMILAR TO THE MATERIAL BEING REMOVED AND WILL BE PAID FOR SEPARATELY.

SALT TOLERANT SOD AND TOP SOIL, 4" (100) RESTORATION WILL NOT BE PAID FOR SEPARATELY, BUT SHALL BE INCLUDED IN THE COST OF CURB OR CURB AND GUTTER REMOVAL AND REPLACEMENT.

- ② CURB OR CURB AND GUTTER REPLACEMENT SHALL MATCH THE SHAPE OF THE EXISTING CURB OR CURB AND GUTTER UNLESS OTHERWISE SPECIFIED.
- ③ FOR CURB OR CURB AND GUTTER REMOVAL AND REPLACEMENT ADJACENT TO FLEXIBLE PAVEMENT DELETE EPOXY COATED TIE BARS.
- ④ LONGITUDINAL BARS, IF ENCOUNTERED IN THE EXISTING CURB OR CURB AND GUTTER, ARE NOT TO BE REPLACED. CUTTING AND REMOVING LONGITUDINAL BARS SHALL BE INCLUDED IN THE COST OF CURB OR CURB AND GUTTER REMOVAL AND REPLACEMENT.
- ⑤ THE COST OF HMA SURFACE REMOVAL IN THE EXISTING GUTTER FLAG SHALL BE INCLUDED IN THE COST OF THE CURB AND GUTTER REMOVAL AND REPLACEMENT.
- ⑥ THE REMOVAL AND REPLACEMENT OF THE EXISTING CURB OR CURB AND GUTTER SHALL BE DONE IN ACCORDANCE WITH THE APPLICABLE PORTIONS OF SECTION 440 AND 606 OF THE STANDARD SPECIFICATIONS.
- ⑦ THE LOCATIONS OF REMOVAL AND REPLACEMENT OF EXISTING CURB OR CURB AND GUTTER SHALL BE DETERMINED BY THE RESIDENT ENGINEER AT THE TIME OF CONSTRUCTION.

UNSUITABLE SUB-BASE MATERIAL TO BE REMOVED, IF DIRECTED BY THE ENGINEER, SHALL BE REPLACED WITH EITHER SUB-BASE GRANULAR MATERIAL, TYPE B OR ADDITIONAL THICKNESS OF CONCRETE.

REMOVAL AND REPLACEMENT 4" (100) OR LESS IS INCLUDED IN THE COST OF CURB OR CURB AND GUTTER REMOVAL AND REPLACEMENT.

REMOVAL AND REPLACEMENT IN EXCESS OF 4" (100) WILL BE PAID FOR IN ACCORDANCE WITH ARTICLE 109.04 OF THE STANDARD SPECIFICATIONS.

PROPOSED #6 (20) EPOXY COATED TIE BARS 24" (600) LONG AT 24" (600) CENTERS WILL NOT BE PAID FOR SEPARATELY. DELETE EPOXY COATED TIE BARS IF EXISTING TIE BARS ARE USUABLE AS DETERMINED BY THE ENGINEER. (SEE NOTE ③).

BASIS OF PAYMENT:
THIS WORK WILL BE PAID FOR AT THE CONTRACT UNIT PRICE PER FOOT (METER) FOR "CURB REMOVAL AND REPLACEMENT" OR "COMBINATION CONCRETE CURB AND GUTTER REMOVAL AND REPLACEMENT".

ALL DIMENSIONS ARE IN INCHES (MILLIMETERS) UNLESS OTHERWISE SHOWN.

REVISIONS	
NAME	DATE
A. HOUSEH	03/11/94
R. SHAH	02/24/95
R. SHAH	03/02/95
R. SHAH	08/19/96
R. SHAH	09/12/96
R. SHAH	09/19/96
R. SHAH	10/03/96
A. ABBAS	03/21/97
M. GOMEZ	01/22/01
R. BORO	01/01/07

ILLINOIS DEPARTMENT OF TRANSPORTATION
CURB OR CURB AND GUTTER REMOVAL AND REPLACEMENT

SCALE: VERT. NONE
HORIZ. 1" = 10'
PLOT DATE: 3/20/2007

DRAWN BY
CHECKED BY

BD600-06 (BD-24)

REVISION DATE: 01/01/07

CURB OR CURB AND GUTTER REMOVAL AND REPLACEMENT

PLOT DATE = 3/20/2007
 PLOT SCALE = 1/8" = 1'-0"
 USER NAME = atandpa

F.A.P. RTE.	SECTION	COUNTY	TOTAL SHEETS	SHEET NO.
846	(4,4R,&5)RS-7	WILL	35	20
STA.	TO STA.			
FED. ROAD DIST. NO. 1		ILLINOIS	FED. AID PROJECT	

CONTRACT NO. 62364

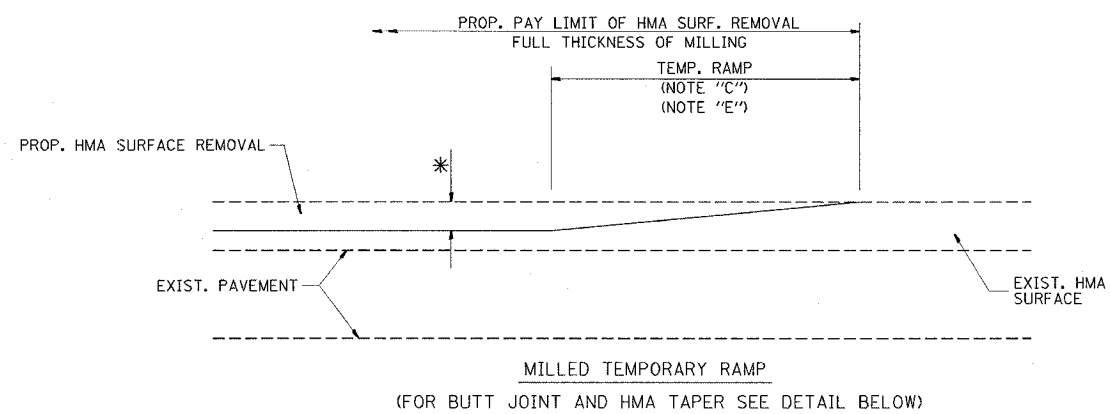

MILLED TEMPORARY RAMP
(FOR BUTT JOINT AND HMA TAPER SEE DETAIL BELOW)

OPTION 1

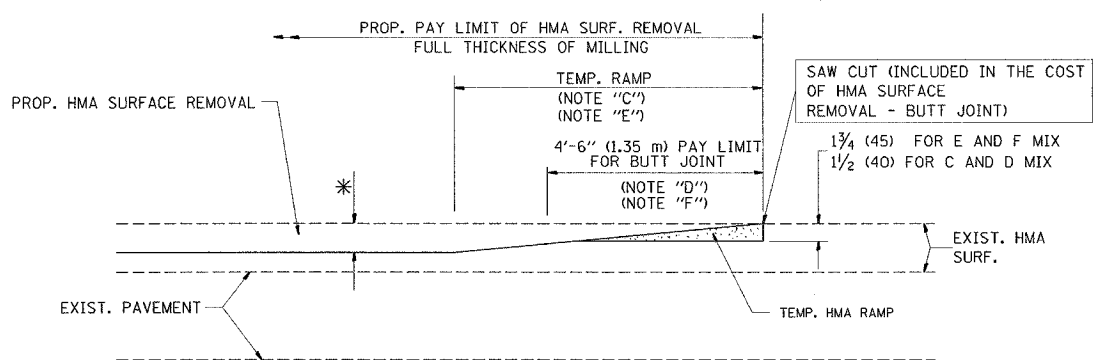

HMA CONSTRUCTED TEMPORARY RAMP
(FOR BUTT JOINT AND HMA TAPER SEE DETAIL BELOW)

OPTION 2
TYPICAL TEMPORARY RAMP

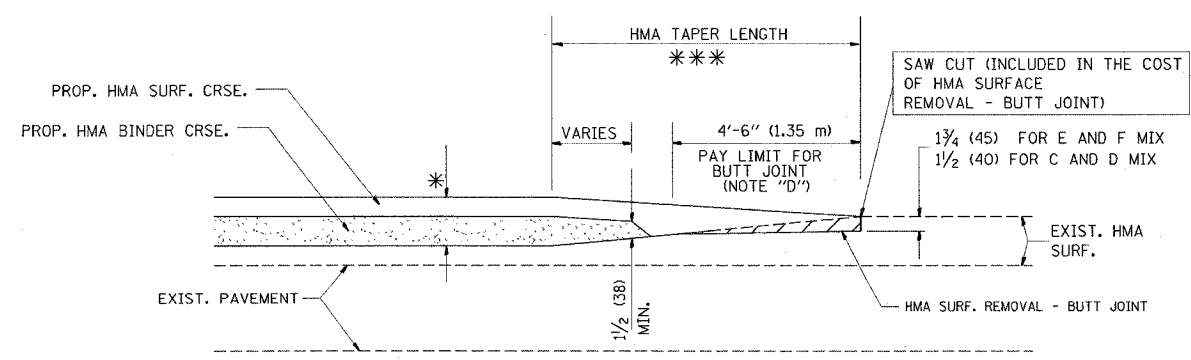

BUTT JOINT AND HMA TAPER
TYPICAL BUTT JOINT AND HMA TAPER
FOR MILLING AND RESURFACING

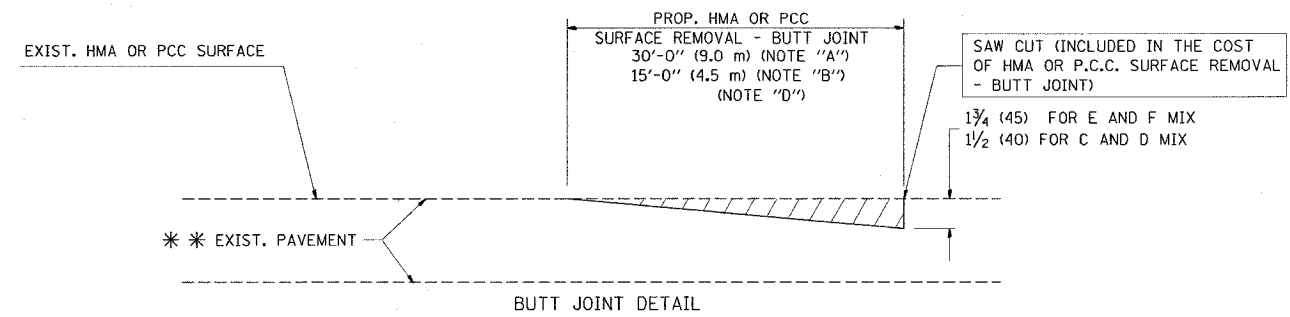

BUTT JOINT DETAIL

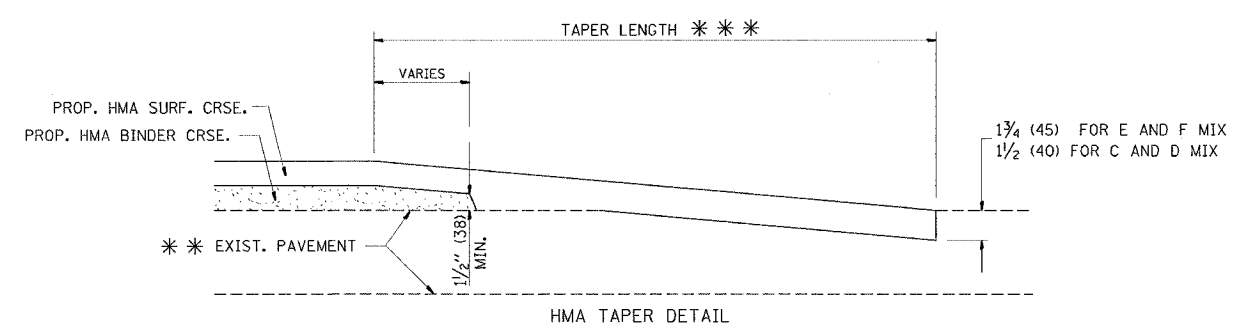

HMA TAPER DETAIL

TYPICAL BUTT JOINT AND HMA TAPER
FOR RESURFACING ONLY

*** PC CONCRETE, HMA OR HMA RESURFACED PAVEMENT.

NOTES

- A: MAINLINE ROADWAYS AND MAJOR SIDE ROADS.
 - B: MINOR SIDE ROADS.
 - C: THE TEMP. RAMP SHALL BE CONSTRUCTED IMMEDIATELY UPON REMOVAL OF THE EXISTING HMA SURFACE.
 - D: THE BUTT JOINT SHALL BE CONSTRUCTED IMMEDIATELY PRIOR TO PLACING THE PROPOSED HMA COURSES.
 - E: TAPER THE TEMP. RAMP AT A RATE OF 3'-0" (900 mm) PER 1 INCH (25 mm) OF MILLING THICKNESS.
 - F: INSTALLATION AND REMOVAL OF THE 4'-6" (1.35 m) TEMP. RAMP IS INCLUDED IN COST OF HMA SURFACE REMOVAL - BUTT JOINT
 - G: SEE ARTICLE 406.08 AND 406.14 OF THE STANDARD SPECIFICATIONS FOR "HMA AND/OR PCC SURFACE REMOVAL, BUTT JOINT".
- * SEE TYPICAL SECTIONS FOR MILLING THICKNESS.
- *** 20'-0" (6.1 m) PER 1 (25) RESURFACING (NOTE "A")
10'-0" (3.0 m) PER 1 (25) RESURFACING (NOTE "B")

ALL DIMENSIONS ARE IN INCHES (MILLIMETERS) UNLESS OTHERWISE SHOWN.

BASIS OF PAYMENT:

THE BUTT JOINT WILL BE PAID FOR AT THE CONTRACT UNIT PRICE PER SQUARE YARD (SQUARE METER) FOR "HOT-MIX ASPHALT SURFACE REMOVAL - BUTT JOINT" OR FOR "PORTLAND CEMENT CONCRETE SURFACE REMOVAL - BUTT JOINT".

REVISIONS	
NAME	DATE
M. DE YONG	6-13-90
M. DE YONG	7-3-90
M. DE YONG	3-27-92
R. SHAH	09/09/94
R. SHAH	10/25/94
A. ABBAS	03/21/97
M. GOMEZ	04/06/01
R. BORO	01/01/07

ILLINOIS DEPARTMENT OF TRANSPORTATION
BUTT JOINT AND HMA TAPER DETAILS
SCALE: VERT. NONE
HORIZ. PLOT DATE: 3/20/2007
DRAWN BY
CHECKED BY

PLOT DATE = 3/20/2007
 FILE NAME = c:\projects\bd400\2007\010107\bd400-05.dwg
 USER NAME = standco

F.A.P. RTE.	SECTION	COUNTY	TOTAL SHEETS	SHEET NO.
B46	(4,4R,&5)RS-7	WILL	35	21
STA.		TO STA.		
FED. ROAD DIST. NO.	ILLINOIS FED. AID PROJECT		CONTRACT NO. 62364	

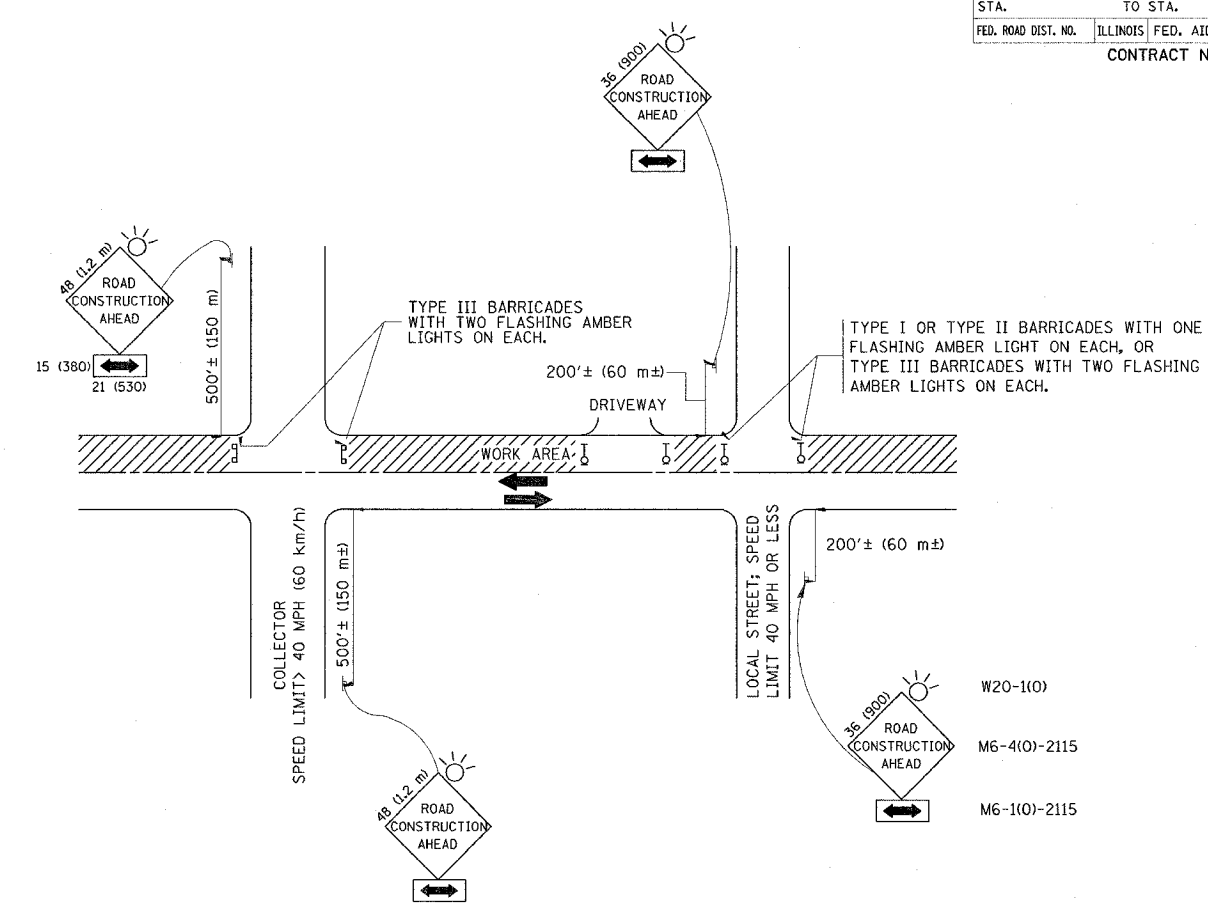

TRAFFIC CONTROL AND PROTECTION FOR SIDE ROADS, INTERSECTIONS, AND DRIVEWAYS

NOTES:

- A. FOR NO LANE RESTRICTION ON THE SIDE ROAD OR DRIVEWAYS
- SIDE ROAD WITH A SPEED LIMIT OF 40 MPH (60 km/h) OR LESS AS SHOWN ON THE DRAWING AND AS DIRECTED BY THE ENGINEER:
 - ONE ROAD CONSTRUCTION AHEAD SIGN 36 x 36 (900x900) WITH A FLASHER AND FLAG MOUNTED ON IT APPROXIMATELY 200' (60 m) IN ADVANCE OF THE MAIN ROUTE.
 - THE CLOSED PORTION OF THE MAIN ROUTE SHALL BE PROTECTED BY BLOCKING WITH TYPE I, TYPE II OR TYPE III BARRICADES, 1/3 OF THE CROSS SECTION OF THE CLOSED PORTION.
 - SIDE ROAD WITH A SPEED LIMIT GREATER THAN 60 km/h (40 MPH) AS SHOWN ON THE DRAWING AND AS DIRECTED BY THE ENGINEER:
 - ONE ROAD CONSTRUCTION AHEAD SIGN 48 x 48 (1.2 m x 1.2 m) WITH A FLASHER MOUNTED ON IT APPROXIMATELY 500' (150 m) IN ADVANCE OF THE MAIN ROUTE.
 - THE CLOSED PORTION OF THE MAIN ROUTE SHALL BE PROTECTED BY BLOCKING WITH TYPE III BARRICADES, 1/2 OF THE CROSS SECTION OF THE CLOSED PORTION.
 - WHEN THE SIDE ROAD LIES BETWEEN THE BEGINNING OF THE MAINLINE SIGNING AND THE WORK ZONE, A SINGLE HEADED ARROW (M6-1) SHALL BE USED IN LIEU OF THE DOUBLE HEADED ARROW (M6-4).
- B. FOR A LANE CLOSURE ON A SIDE ROAD OR DRIVEWAY:
- USE APPLICABLE PORTIONS OF THE TYPICAL APPLICATION OF TRAFFIC CONTROL DEVICES (STD. 701501, STD. 701606 OR THE APPROPRIATE STANDARD). THE SPACING OF SIGNS AND BARRICADES SHALL BE ADJUSTED FOR FIELD CONDITIONS AS DIRECTED BY THE ENGINEER. THE DIRECTIONAL ARROW SHALL BE COVERED OR REMOVED WHEN NO LONGER CONSISTENT WITH THE SIDE ROAD LANE CLOSURE.
- C. ADVANCE WARNING SIGNS ARE TO BE OMITTED ON DRIVEWAY UNLESS OTHERWISE NOTED.
- D. THE TRAFFIC CONTROL AND PROTECTION FOR SIDE ROADS, INTERSECTIONS, AND DRIVEWAYS SHALL BE INCIDENTAL TO THE COST OF SPECIFIED TRAFFIC CONTROL STANDARDS OR ITEMS.

All dimensions are in millimeters (inches) unless otherwise shown.

REVISIONS	
NAME	DATE
LHA	6/89
T. RAMMACHER	09/08/94
J. OBERLE	10/18/95
A. HOUSEH	03/06/96
A. HOUSEH	10/15/96
T. RAMMACHER	01/06/00

ILLINOIS DEPARTMENT OF TRANSPORTATION
 TRAFFIC CONTROL AND PROTECTION
 FOR
 SIDE ROADS, INTERSECTIONS, AND
 DRIVEWAYS

SCALE: DATE: 3/20/2007
 DRAWN BY: CHECKED BY: TC-10

PLOT DATE = 3/20/2007
 PLOT SCALE = 3/20/2007
 USER NAME = steedpa

F.A.P. RTE.	SECTION	COUNTY	TOTAL SHEETS	SHEET NO.
846	(4,4R,&5)RS-7	WILL	35	22
STA.	TO STA.			
FED. ROAD DIST. NO.	ILLINOIS	FED. AID PROJECT		
CONTRACT NO. 62364				

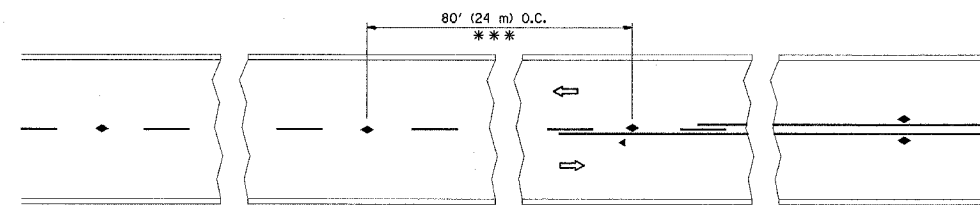

*** REDUCE TO 40' (12 m) O.C. ON CURVES WITH POSTED OR ADVISORY SPEED 45 M.P.H. (70 km/h) OR LESS.

TWO-LANE/TWO-WAY

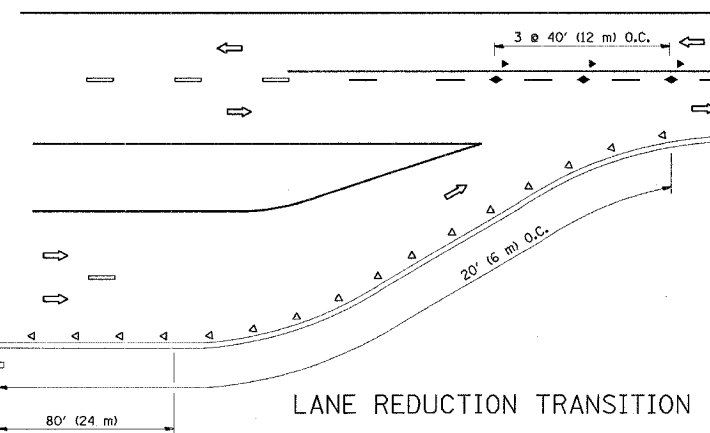

LANE REDUCTION TRANSITION

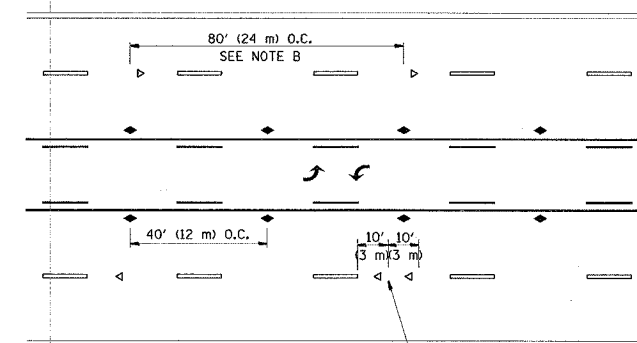

TWO-WAY LEFT TURN

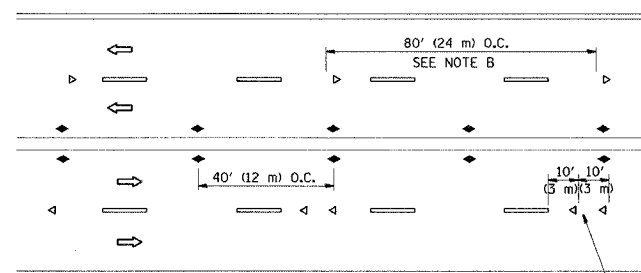

MULTI-LANE/UNDIVIDED

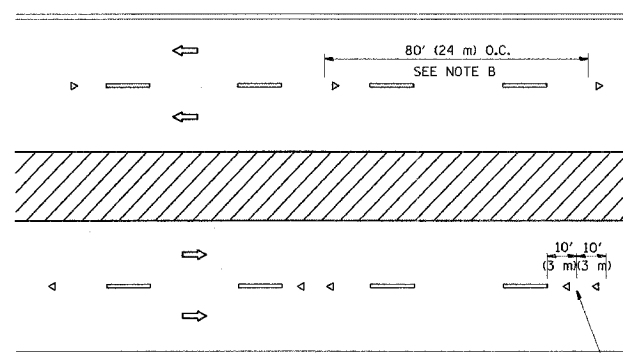

MULTI-LANE/DIVIDED

GENERAL NOTES

1. MARKERS USED WITH DASHED LINES SHALL BE CENTERED IN THE GAP BETWEEN SEGMENTS.
2. MARKERS USED ADJACENT TO SOLID LINES SHALL BE OFFSET 2 TO 3 (50 TO 75) TOWARD TRAFFIC AS SHOWN.
3. MARKERS THROUGH TANGENTS LESS THAN 500' (150 m) IN LENGTH BETWEEN CURVES SHALL BE INSTALLED AT THE LESSER OF THE TWO CURVE SPACINGS.

LANE MARKER NOTES

- B. REDUCE TO 40' (12 m) O.C. ON CURVES WHERE ADVISORY SPEEDS ARE 10 M.P.H (20 km/h) LOWER THAN POSTED SPEEDS.
- A. USE DOUBLE LANE LINE MARKERS SPACED AS SHOWN.

SYMBOLS

- YELLOW STRIPE
- WHITE STRIPE
- ◀ ONE-WAY AMBER MARKER
- ◀ ONE-WAY CRYSTAL MARKER (W/O)
- ◆ TWO-WAY AMBER MARKER

DESIGN NOTES

1. DOUBLE LANE LINE MARKERS SHALL BE USED UNLESS SPECIFIED OTHERWISE.
2. EXCEPT AS SHOWN ON THE LANE REDUCTION TRANSITION AND FREEWAY EXIT RAMP DETAIL, MARKERS ARE NOT TO BE SPECIFIED ON RIGHT EDGE LINES.
3. THE EXACT MARKER LIMITS, SPACING, AND COLOR SHOULD BE INCLUDED IN THE PLANS.
4. MARKERS SHOULD NOT BE USED ALONGSIDE CURBS EXCEPT FOR EXTREMELY SHORT SECTIONS OF CURBS WHERE NOT MORE THAN TWO MARKERS WOULD BE INVOLVED.

All dimensions are in millimeters (inches) unless otherwise shown.

REVISIONS	
NAME	DATE
T. RAMMACHER	09-19-94
T. RAMMACHER	03-12-99
T. RAMMACHER	01-06-00

ILLINOIS DEPARTMENT OF TRANSPORTATION
 TYPICAL APPLICATIONS
 RAISED REFLECTIVE PAVEMENT
 MARKERS (SNOW-PLOW RESISTANT)

SCALE: NONE
 DATE: 3/20/2007

DRAWN BY CADD
 CHECKED BY
 TC-11

REVISION DATE: 01/06/00

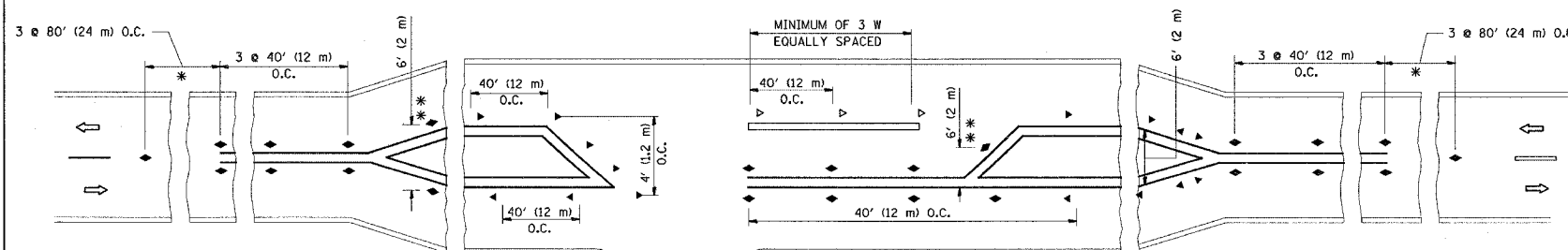

* SEE TWO-LANE/TWO-WAY WHERE MARKERS CONTINUE
 ** WHERE THE MEDIAN WIDTH IS 6' (2 m) OR LESS USE TWO-WAY MARKERS.

LEFT TURN

PLOT DATE = 9/20/2007
 FILE NAME = C:\p\proj\108202\108202.dwg
 PLOT SCALE = 50.0000 / IN.
 USER NAME = steedp

F.A.P. RTE.	SECTION	COUNTY	TOTAL SHEETS	SHEET NO.
846	(4,4R,&5)RS-7	WILL	35	23
STA.	TO STA.			
FED. ROAD DIST. NO.	ILLINOIS	FED. AID PROJECT		
CONTRACT NO. 62364				

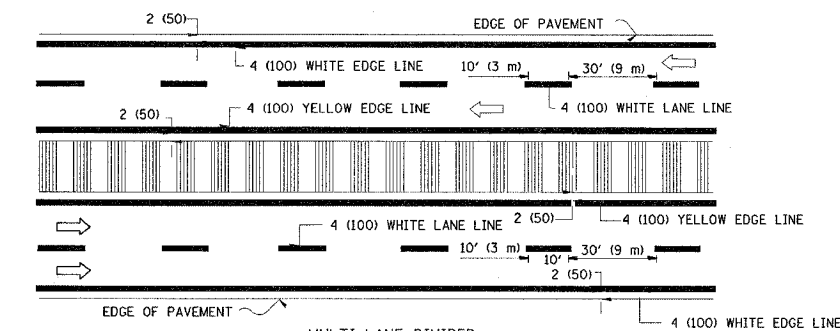
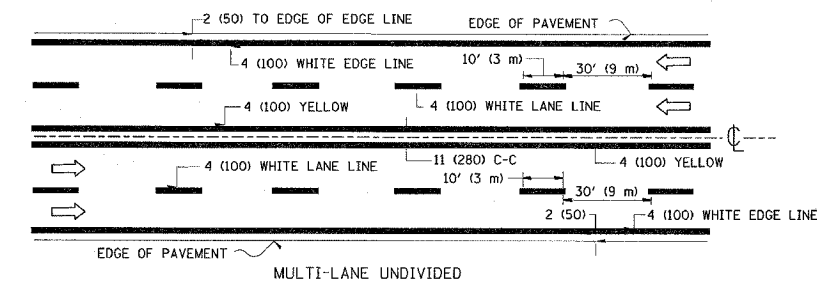
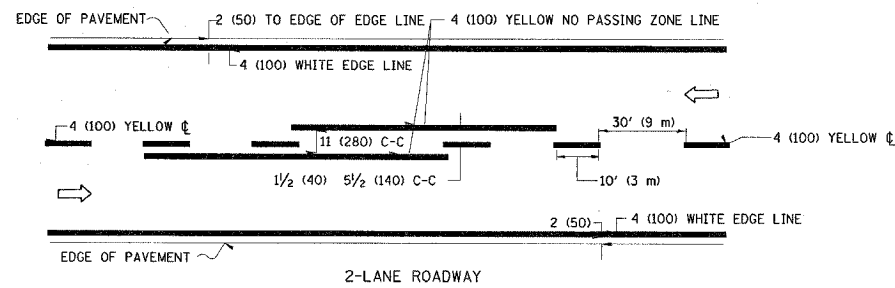

NOTE: MEDIANS WITH BARRIER CURB DO NOT REQUIRE AN EDGE LINE

TYPICAL LANE AND EDGE LINE MARKING

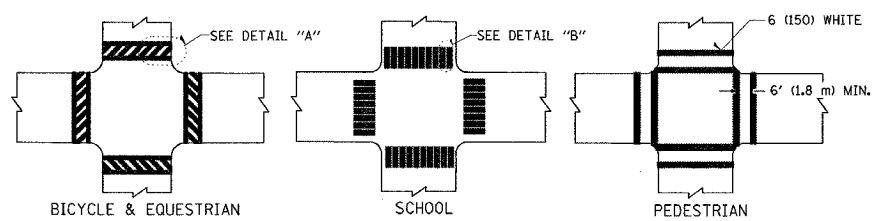

TYPICAL CROSSWALK MARKING

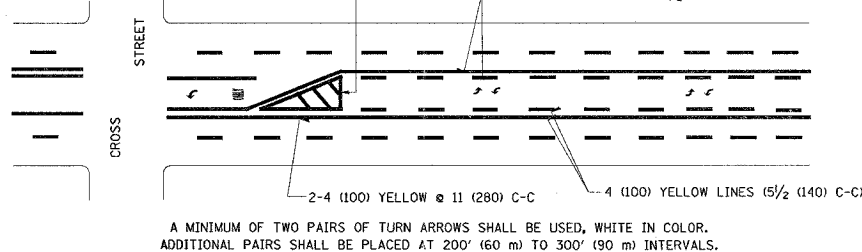
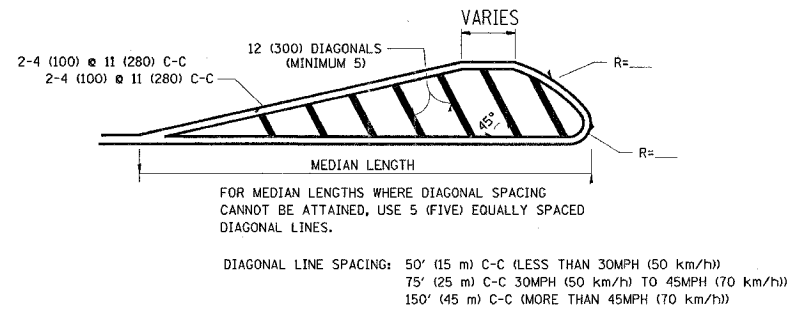
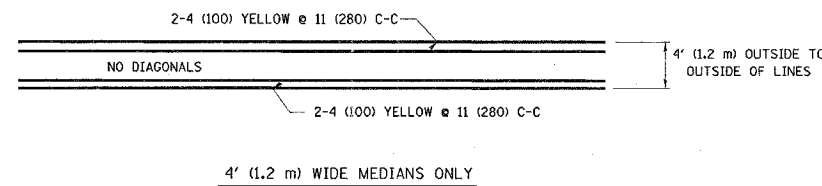

TYPICAL PAINTED MEDIAN MARKING

TYPICAL LEFT (OR RIGHT) TURN LANE

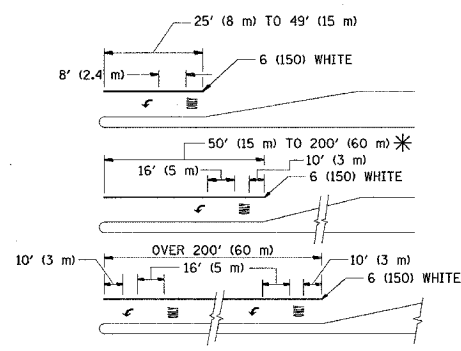

FULL SIZE LETTERS 8' (2.4 m) AND ARROWS SHALL BE USED.
 * TURN LANES IN EXCESS OF 400' (120 m) IN LENGTH MAY HAVE AN ADDITIONAL SET OF ARROW - "ONLY" INSTALLED MIDWAY BETWEEN THE OTHER TWO SETS OF ARROW - "ONLY".

TYPICAL TURN LANE MARKING

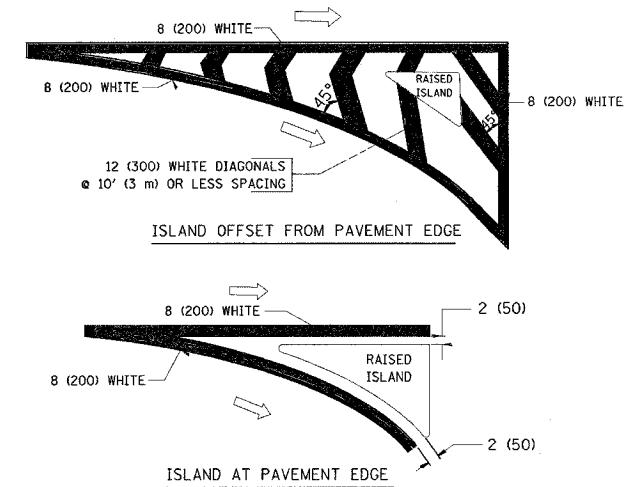

TYPICAL ISLAND MARKING

TYPE OF MARKING	WIDTH OF LINE	PATTERN	COLOR	SPACING / REMARKS
CENTERLINE ON 2 LANE PAVEMENT	4 (100)	SKIP-DASH	YELLOW	10' (3 m) LINE WITH 30' (9 m) SPACE
CENTERLINE ON MULTI-LANE UNDIVIDED PAVEMENT	2 @ 4 (100)	SOLID	YELLOW	11 (280) C-C
NO PASSING ZONE LINES: FOR ONE DIRECTION FOR BOTH DIRECTIONS	4 (100) 2 @ 4 (100)	SOLID SOLID	YELLOW YELLOW	5/2 (140) C-C FROM SKIP-DASH CENTERLINE 11 (280) C-C OMIT SKIP-DASH CENTERLINE BETWEEN
LANE LINES	4 (100) 5 (125) ON FREEWAYS	SKIP-DASH SKIP-DASH	WHITE WHITE	10' (3 m) LINE WITH 30' (9 m) SPACE
DOTTED LINES (EXTENSIONS OF CENTER, LANE OR TURN LANE MARKINGS)	SAME AS LINE BEING EXTENDED	SKIP-DASH	SAME AS LINE BEING EXTENDED	2' (600) LINE WITH 6' (1.8 m) SPACE
EDGE LINES	4 (100)	SOLID	YELLOW-LEFT WHITE-RIGHT	OUTLINE MOUNTABLE MEDIANS IN YELLOW; EDGE LINES ARE NOT USED NEXT TO BARRIER CURB
TURN LANE MARKINGS	6 (150) LINE; FULL SIZE LETTERS & SYMBOLS (8' (2.4m))	SOLID	WHITE	SEE TYPICAL TURN LANE MARKING DETAIL
TWO WAY LEFT TURN MARKING	2 @ 4 (100) EACH DIRECTION 8' (2.4m) LEFT ARROW	SKIP-DASH AND SOLID IN PAIRS	YELLOW WHITE	10' (3 m) LINE WITH 30' (9 m) SPACE FOR SKIP-DASH; 5/2 (140) C-C BETWEEN SOLID LINE AND SKIP-DASH LINE SEE TYPICAL TWO-WAY LEFT TURN MARKING DETAIL
CROSSWALK LINES (PEDESTRIAN) A. DIAGONALS (BIKE & EQUESTRIAN) B. LONGITUDINAL BARS (SCHOOL)	2 @ 6 (150) 12 (300) @ 45° 12 (300) @ 90°	SOLID SOLID SOLID	WHITE WHITE WHITE	NOT LESS THAN 6' (1.8 m) APART 2' (600) APART SEE TYPICAL CROSSWALK MARKING DETAILS.
STOP LINES	24 (600)	SOLID	WHITE	PLACE 4' (1.2 m) IN ADVANCE OF AND PARALLEL TO CROSSWALK, IF PRESENT. OTHERWISE, PLACE AT DESIRED STOPPING POINT, PARALLEL TO CROSSROAD CENTERLINE, WHERE POSSIBLE
PAINTED MEDIANS	2 @ 4 (100) WITH 12 (300) DIAGONALS @ 45° NO DIAGONALS USED FOR 4' (1.2 m) WIDE MEDIANS	SOLID	YELLOW: TWO WAY TRAFFIC WHITE: ONE WAY TRAFFIC	11 (280) C-C FOR THE DOUBLE LINE SEE TYPICAL PAINTED MEDIAN MARKING.
GORE MARKING AND CHANNELIZING LINES	8 (200) WITH 12 (300) DIAGONALS @ 45°	SOLID	WHITE	DIAGONALS: 15' (4.5 m) C-C (LESS THAN 30MPH (50 km/h)) 20' (6 m) C-C 30MPH (50 km/h) TO 45MPH (70 km/h) 30' (9 m) C-C (OVER 45MPH (70 km/h))
RAILROAD CROSSING	24 (600) TRANSVERSE LINES; "RR" IS 6' (1.8 m) LETTERS; 16 (400) LINE FOR "X"	SOLID	WHITE	SEE STATE STANDARD 780001 AREA OF: "R"=3.6 SQ. FT. (0.33 m ²) EACH "X"=54.0 SQ. FT. (5.0 m ²)
SHOULDER DIAGONALS	12 (300) @ 45°	SOLID	WHITE - RIGHT YELLOW - LEFT	50' (15 m) C-C (LESS THAN 30MPH (50 km/h)) 75' (25 m) C-C (30 MPH (50 km/h) TO 45MPH (70 km/h)) 150' (45 m) C-C (OVER 45MPH (70 km/h))

FOR FURTHER DETAILS ON PAVEMENT MARKING REFER TO STANDARD SPECIFICATIONS FOR ROAD AND BRIDGE CONSTRUCTION AND STATE STANDARD 780001.

All dimensions are in millimeters (inches) unless otherwise shown.

REVISIONS	
NAME	DATE
EVERS	03-19-90
T. RAMMACHER	10-27-94
ALEX HOUSEH	10-09-96
ALEX HOUSEH	10-17-96
T. RAMMACHER	01-06-00

ILLINOIS DEPARTMENT OF TRANSPORTATION
 DISTRICT ONE
 TYPICAL PAVEMENT MARKINGS

SCALE: NONE
 DATE: 3/20/2007

DRAWN BY CADD
 CHECKED BY

TC-13
 REVISION DATE: 01/06/00



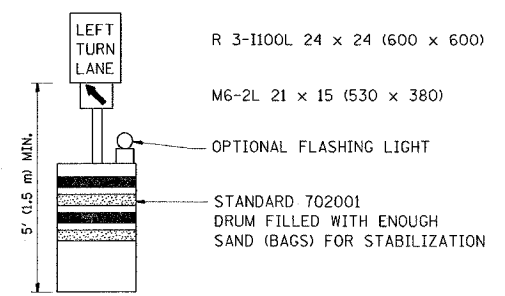
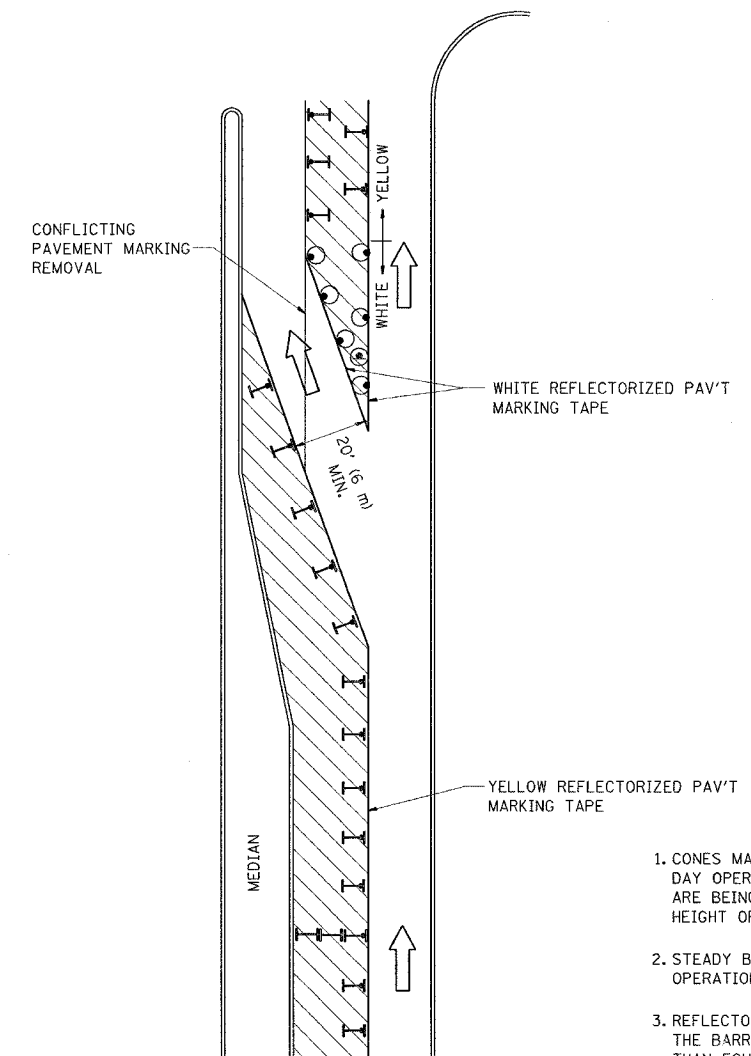



F.A.P. RTE.	SECTION	COUNTY	TOTAL SHEETS	SHEET NO.
846	(4,4R,8,5)RS-7	WILL	35	24
STA.		TO STA.		
FED. ROAD DIST. NO.	ILLINOIS	FED. AID PROJECT		
CONTRACT NO. 62364				

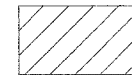

GENERAL NOTES

1. CONES MAY BE SUBSTITUTED FOR BARRICADES OR DRUMS AT HALF THE SPACING DURING DAY OPERATIONS. CONES SHALL BE A MINIMUM OF 28 (710) IN HEIGHT. WHEN CONES ARE BEING USED, THE "LEFT TURN LANE" SIGN MAY BE SKID MOUNTED AT A MINIMUM HEIGHT OF 5' (1.5 m).
2. STEADY BURNING LIGHTS WILL NOT BE REQUIRED ON BARRICADES OR DRUMS FOR DAY OPERATIONS. ALL LIGHTS SHALL BE MONODIRECTIONAL.
3. REFLECTORIZED TEMPORARY PAVEMENT MARKING TAPE SHALL BE PLACED THROUGHOUT THE BARRICADED AREA OF EACH TURN BAY WHERE THE CLOSURE TIME IS GREATER THAN FOURTEEN DAYS.
4. THIS APPLICATION ALSO APPLIES WHEN WORK IS BEING PERFORMED IN THE RIGHT LANE(S) AND THE RIGHT TURN BAY IS TO REMAIN OPEN. UNDER THIS CONDITION, "RIGHT TURN LANE" R3-100 24 x 24 (600 x 600) AND M6-2R 21 x 15 (530 x 380) SHALL BE USED.
5. THESE CONTROLS SHALL SUPPLEMENT MAINLINE TRAFFIC CONTROL FOR LANE CLOSURES.
6. LONGITUDINAL DIMENSIONS MAY BE ADJUSTED TO FIT FIELD CONDITIONS.
7. FORM BT 725 IS REQUIRED.
8. TRAFFIC CONTROL AND PROTECTION AT TURN BAYS (TO REMAIN OPEN TO TRAFFIC) SHALL BE INCLUDED IN THE COST SPECIFIED TRAFFIC CONTROL STANDARDS OR ITEMS.

LEGEND

-  WORK AREA
-  LANE OPEN TO TRAFFIC
-  TYPE I OR II BARRICADE WITH STEADY BURN LIGHT
-  DRUM WITH STEADY BURN LIGHT
-  DRUM WITH SIGN (WITH OPTIONAL FLASHING LIGHT) SEE DETAIL
-  TYPE I OR II CHECK BARRICADE WITH FLASHING LIGHT

All dimensions are in millimeters (inches) unless otherwise shown.

REVISIONS	
NAME	DATE
T. RAMMACHER	09/08/94
A. HOUSEH	11/07/95
A. HOUSEH	10/12/96
T. RAMMACHER	01/06/00

ILLINOIS DEPARTMENT OF TRANSPORTATION
**TRAFFIC CONTROL AND PROTECTION
 AT TURN BAYS
 (TO REMAIN OPEN TO TRAFFIC)**

SCALE: NONE
 DATE: 3/20/2007

DRAWN BY
 CHECKED BY LHA

TC-14
 REVISION DATE: 01/06/00

PLOT DATE = 3/20/2007
 PLOT SCALE = 5/8" = 1' / IN.
 USER NAME = steedra

F.A.P. RTE.	SECTION	COUNTY	TOTAL SHEETS	SHEET NO.
846	(4,4R,&5)RS-7	WILL	35	25
STA.	TO STA.			
FED. ROAD DIST. NO.	ILLINOIS	FED. AID PROJECT		
CONTRACT NO. 62364				

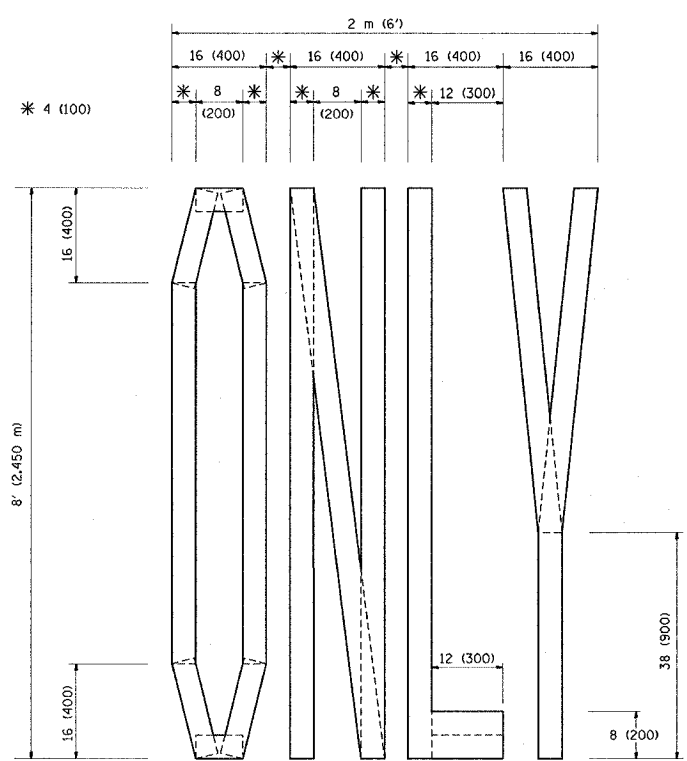

QUANTITY
 4 (100) LINE = 64.1 ft. (19.7 m)
 21.1 sq. ft. (1.97 sq. m)

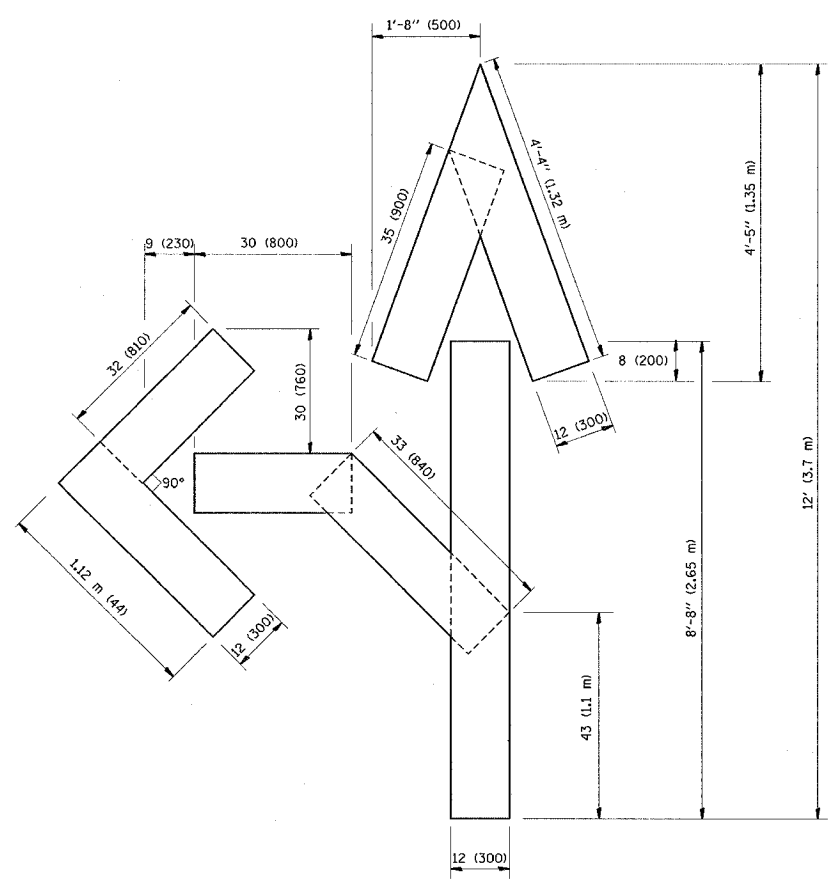

QUANTITY
 4 (100) LINE = 82.5 ft. (25.3 m)
 27.5 sq. ft. (2.53 sq. m)

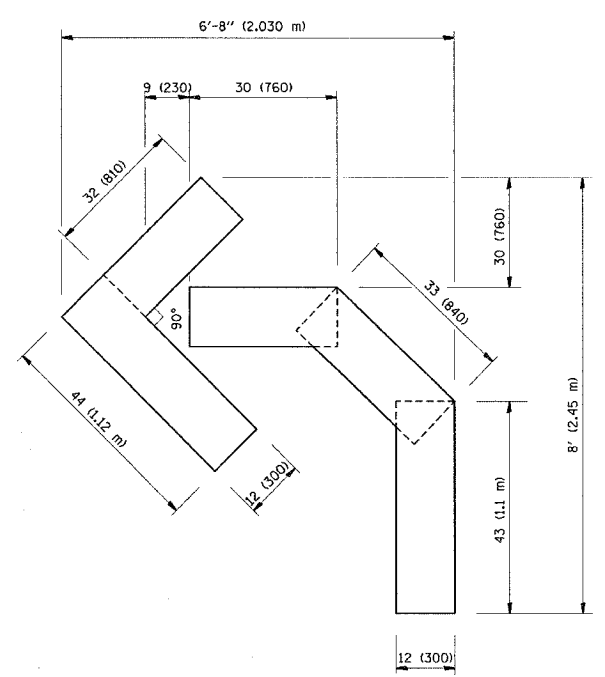

QUANTITY
 4 (100) LINE = 45.5 ft. (13.9 m)
 15.2 sq. ft. (1.39 sq. m)

All dimensions are in millimeters (inches) unless otherwise shown.

REVISIONS	
NAME	DATE
T. RAMMACHER	09/18/94
J. OBERLE	06/01/96
T. RAMMACHER	06/05/98
T. RAMMACHER	11/04/97
T. RAMMACHER	03/02/98
E. GOMEZ	08/28/00

ILLINOIS DEPARTMENT OF TRANSPORTATION
**PAVEMENT MARKING
 LETTERS AND SYMBOLS
 FOR TRAFFIC STAGING**

SCALE: NONE
 DATE: 3/20/2007
 DRAWN BY CADD
 CHECKED BY TC-16

PLOT DATE = 3/20/2007
 FILE NAME = c:\projects\100222\100222.dwg
 PLOT SCALE = 3/8"=1'-0"
 USER NAME = steedca

F.A.P. RTE.	SECTION	COUNTY	TOTAL SHEETS	SHEET NO.
B46	(4,4R, & 5)RS-7	WILL	35	26
STA.	TO STA.			
FED. ROAD DIST. NO.	ILLINOIS	FED. AID PROJECT		
CONTRACT NO. 62364				

LOOP DETECTOR NOTES

- EACH PAIR OF LOOP WIRES SHALL BE PLACED IN A SEPARATE UNIT DUCT FROM THE EDGE OF PAVEMENT TO THE HANDHOLE. SPACING BETWEEN THE HOLES DRILLED IN THE PAVEMENT SHALL NOT BE LESS THAN 6" (150 mm). UNIT DUCT SHALL BE INCLUDED IN THE COST OF THE LOOP WIRE.
- THE NUMBER OF LOOP TURNS SHALL BE AS RECOMMENDED BY THE AMPLIFIER MANUFACTURER. ALL ADJACENT SIDES OF THE LOOPS SHALL BE INSTALLED IN SUCH A WAY THAT THE CURRENT FLOW IS IN THE SAME DIRECTION TO REINFORCE ITS MAGNETIC FIELDS FOR SMALL VEHICLE DETECTION.
- EACH LOOP LEAD-IN SHALL BE IDENTIFIED AND PERMANENTLY TAGGED IN THE HANDHOLE. EACH LEAD-IN CABLE TAG SHALL INDICATE THE LOCATION OF THE LOOP, LOOP ROTATION (CLOCKWISE/COUNTERCLOCKWISE), LOOP LEAD-IN DIRECTION (IN OR OUT), LOOP CABLE NUMBER AND LOCATION IN CABINET, AND NUMBER OF TURNS IN THE DETECTOR LOOPS IN WATER PROOF INK AS INDICATED ON THE DISTRICT 1 STANDARD TRAFFIC SIGNAL DESIGN DETAIL. THE CONTRACTOR SHALL MARK LOOP LOCATIONS ON RECORD DRAWINGS AND PRESENT TO THE ENGINEER AFTER FINAL INSPECTION. LOOPS SHALL BE MARKED BY LANE AND LOOP NUMBER. SEE DETAIL BELOW.
- ALL LOOP CABLE SHALL BE FASTENED WITH PLASTIC TIE WRAP TO THE HANDHOLE HOOKS.
- IN ASPHALT PAVEMENT, LOOPS SHOULD BE PLACED IN THE BINDER AND DIVEHOLES MARKED AT THE CURB WITH A SAW-CUT. THE SAW-CUT SHALL BE CUT IN ACCORDANCE WITH LOCAL AND E.P.A. DUST CONTROL REQUIREMENTS. DETECTOR LOOP(S) SHALL NOT BE INSTALLED IN WET CONDITIONS AND THE SAW-CUTS MUST BE FREE OF DEBRIS AND RESIDUE SUCH AS DUST AND WATER WHICH IS TO BE ACHIEVED BY THE USE OF COMPRESSED AIR, WIRE BRUSHING AND HEAT DRYING ACCORDING TO SEALANT MANUFACTURER REQUIREMENTS. THE DETECTOR WIRE SHALL BE HELD IN PLACE BY THE USE OF FORM WEDGES. WEDGES SHALL BE SPACED NO MORE THAN 18" (450 mm) APART.
- LOOP SPLICES SHALL BE SOLDERED USING A SOLDERING IRON. BLOW TORCHES OR OTHER DEVICES WHICH OXIDIZE COPPER CABLE SHALL NOT BE ALLOWED FOR SOLDERING OPERATIONS. SEE DETAIL BELOW RIGHT.
- PREFORMED DETECTOR LOOPS SHALL BE USED, AS SHOWN ON THE PLANS, WHERE NEW CONCRETE PAVEMENT IS PROPOSED. THE INSTALLATION OF PREFORMED LOOPS SHALL BE IN ACCORDANCE WITH THE DISTRICT 1 SPECIFICATIONS OR AS DIRECTED BY THE ENGINEER.

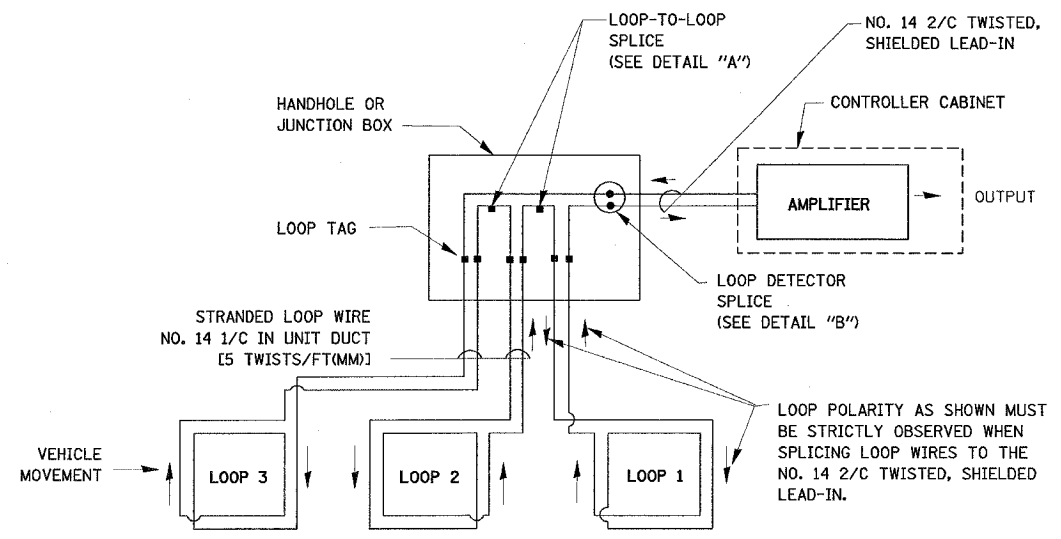

DETECTOR LOOP WIRING SCHEMATIC

- LOOPS SHALL BE SPLICED IN SERIES.
- SAW-CUTS SHALL BE A MINIMUM WIDTH OF 5/16" (8 mm).
- SAW-CUT DEPTHS SHALL BE 3" (75 mm). IF IN CONCRETE, THE SAW-CUT DEPTH SHALL BE TO THE TOP OF THE REINFORCEMENT.
- LOOP CORNERS SHALL BE DRILLED WITH A 2" (50 mm) DIAMETER CORE.

LOOP LEAD-IN CABLE TAG

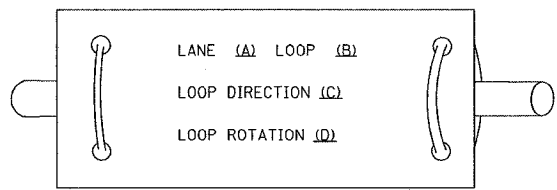

- LANE 1 IS THE LANE CLOSEST TO THE CENTERLINE OF THE ROADWAY
- LOOP #1 IS THE LOOP IN THE LANE CLOSEST TO THE INTERSECTION.
- LABEL LOOP CABLE "IN" OR LOOP CABLE "OUT".
- LABEL LOOP CABLE CLOCKWISE OR LOOP CABLE COUNTERCLOCKWISE.

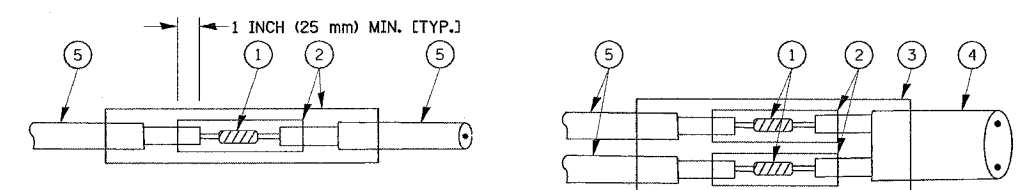

**DETAIL "A"
LOOP-TO-LOOP SPLICE**

**DETAIL "B"
LOOP-TO-CONTROLLER SPLICE**

LOOP DETECTOR SPLICE

- WESTERN UNION SPLICE SOLDERED WITH ROSIN CORE FLUX. ALL EXPOSED SURFACES OF THE SOLDER SHALL BE SMOOTH.
- WCSMW 30/100 HEAT SHRINK TUBE, MINIMUM LENGTH 3" (75 mm), UNDERWATER GRADE.
- WCS 200/750 HEAT SHRINK TUBE, MINIMUM LENGTH 6" (150 mm), UNDERWATER GRADE.
- NO. 14 2/C TWISTED, SHIELDED CABLE.
- LOOP CONDUCTOR WITH FLEXIBLE PLASTIC TUBE.

REVISIONS	
NAME	DATE
CADD	5/30/00
ADD NOTE NO. 8	11/12/01
BUREAU OF TRAFFIC	1-01-02

ILLINOIS DEPARTMENT OF TRANSPORTATION
**DISTRICT ONE
STANDARD TRAFFIC SIGNAL
DESIGN DETAILS**

SCALE: NONE
DATE: 3/20/2007

DRAWN BY: RWP
DESIGNED BY: DAD
CHECKED BY: DAZ
SHEET 1 OF 4

TS05
REVISION DATE: 01/01/02

PLOT DATE = 3/20/2007
 FILE NAME = C:\projects\stdsig\stdsig.dwg
 PLOT SCALE = 50.0000 / IN.
 USER NAME = standee

F.A.P. RTE.	SECTION	COUNTY	TOTAL SHEETS	SHEET NO.
B46	(4,4R,8,5)RS-7	WILL	35	27
STA.	TO STA.			
FED. ROAD DIST. NO.	ILLINOIS FED. AID PROJECT			
CONTRACT NO. 62364				

TRAFFIC SIGNAL MAST ARM AND POST

MAST ARM MOUNTED SIGNAL IN PROPOSED & FUTURE SIDEWALK AREA. INTERSECTION SHOWN WITH PEDESTRIAN SIGNAL AND PUSHBUTTON DETECTOR

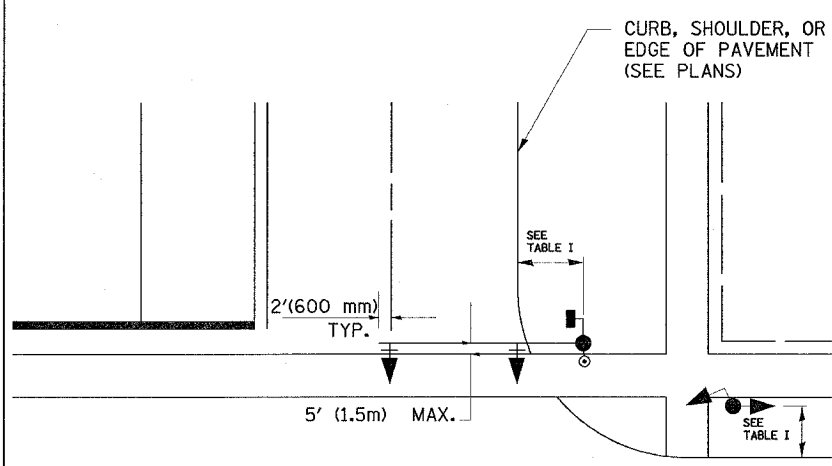

PEDESTRIAN SIGNAL PUSHBUTTON

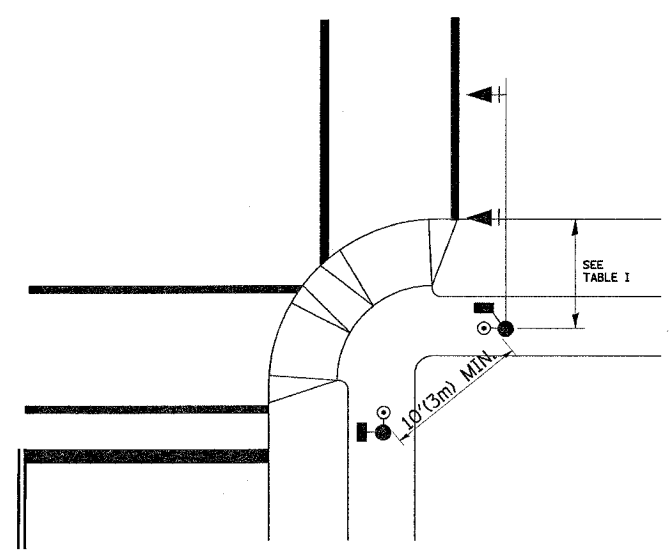

RECOMMENDED PUSHBUTTON LOCATIONS FOR ACCESSIBLE PEDESTRIAN SIGNALS SHALL BE IN ACCORDANCE WITH THE CURRENT MUTCD (SEE NOTE 1). TO MEET MUTCD REQUIREMENTS, PEDESTRIAN SIGNAL PUSHBUTTONS MAY HAVE TO BE MOUNTED ON A SEPARATE POST.

NOTES:

- AT ACCESSIBLE PEDESTRIAN SIGNAL LOCATIONS WITH PEDESTRIAN ACTUATION, EACH PUSHBUTTON SHALL ACTIVATE BOTH THE WALK INTERVAL AND THE ACCESSIBLE PEDESTRIAN SIGNALS.

AT ACCESSIBLE PEDESTRIAN SIGNAL LOCATIONS, PUSHBUTTONS SHOULD CLEARLY INDICATE WHICH CROSSWALK SIGNAL IS ACTUATED BY EACH PUSHBUTTON. PUSHBUTTONS AND TACTILE ARROWS SHOULD HAVE HIGH VISUAL CONTRAST (SEE THE DEPARTMENT OF JUSTICE'S AMERICANS WITH DISABILITIES ACT STANDARDS FOR ACCESSIBLE DESIGN, 1991). TACTILE ARROWS SHOULD POINT IN THE SAME DIRECTION AS THE ASSOCIATED CROSSWALK. AT CORNERS OF SIGNALIZED LOCATIONS WITH ACCESSIBLE PEDESTRIAN SIGNALS WHERE PEDESTRIAN PUSHBUTTONS ARE PROVIDED, THE PUSHBUTTONS SHOULD BE SEPARATED BY THE DISTANCE OF AT LEAST 10 FT (3m). THIS ENABLES PEDESTRIANS WHO HAVE VISUAL DISABILITIES TO DISTINGUISH AND LOCATE THE APPROPRIATE PUSHBUTTON.

PUSHBUTTONS FOR ACCESSIBLE PEDESTRIAN SIGNALS SHOULD BE LOCATED AS FOLLOWS:
 A: ADJACENT TO A LEVEL ALL-WEATHER SURFACE TO PROVIDE ACCESS FROM A WHEELCHAIR, AND WHERE THERE IS AN ALL WEATHER SURFACE, WHEELCHAIR ACCESSIBLE ROUTE TO THE RAMP.
 B: WITHIN 5 FT (1.5m) OF THE CROSSWALK EXTENDED.
 C: WITHIN 10 FT (3m) OF THE EDGE OF CURB, SHOULDER, OR PAVEMENT.
 D: PARALLEL TO THE CROSSWALK TO BE USED (SEE MUTCD FIGURE 4E-2).
 E: NORMAL PEDESTRIAN PUSHBUTTON MOUNTING HEIGHT SHOULD BE 3.5 FT (1.05m) ABOVE ADJACENT SIDEWALK
- PEDESTRIAN SIGNAL FACES SHALL BE MOUNTED WITH THE BOTTOM OF THE HOUSING NOT LESS THAN 8 FT (2.4m) NOR MORE THAN 10 FT (3.0m) ABOVE THE SIDEWALK LEVEL AND SO THERE IS A PEDESTRIAN INDICATION IN THE LINE OF PEDESTRIANS' VISION WHICH PERTAINS TO THE CROSSWALK BEING USED.
- THE BOTTOM OF THE HOUSING OF A VEHICLE SIGNAL FACE, NOT MOUNTED OVER A ROADWAY, SHALL BE AT LEAST 10 FT (3.0m) BUT NOT MORE THAN 15 FT (4.5m) ABOVE THE SIDEWALK OR, ABOVE THE PAVEMENT GRADE AT THE CENTER OF THE HIGHWAY IF NO SIDEWALKS EXIST.
- THE BOTTOM OF THE HOUSING OF A VEHICLE SIGNAL FACE, MOUNTED OVER A ROADWAY, SHALL BE ACCORDING TO CURRENT STATE STANDARDS 877001 AND 877006. (16 FT (5m) MIN., 18 FT (5.5m) MAX., FROM HIGHEST POINT OF PAVEMENT)

PEDESTRIAN SIGNAL POST

PEDESTRIAN SIGNAL HEAD AND PEDESTRIAN PUSHBUTTON DETECTOR LOCATION

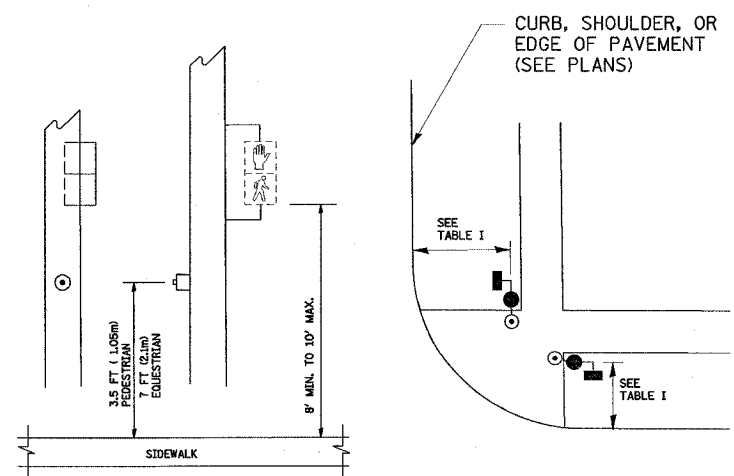

TABLE I

TRAFFIC SIGNAL EQUIPMENT	COMBINATION CONCRETE CURB AND GUTTER (MIN. DIST. FROM BACK OF CURB)	SHOULDER/NON-CURBED AREA (MIN. DIST. FROM EDGE OF PAVEMENT)
TRAFFIC SIGNAL MAST ARM POLE	6 FT (1.8m)	SHOULDER WIDTH + 2FT(0.6m), MINIMUM 10FT(3.0m)
TRAFFIC SIGNAL POST	4 FT (1.2m)	SHOULDER WIDTH + 2FT(0.6m), MINIMUM 10FT(3.0m)
PEDESTRIAN SIGNAL POST	4 FT (1.2m)	SHOULDER WIDTH + 2FT(0.6m), MINIMUM 10FT(3.0m)
PEDESTRIAN PUSHBUTTON	SEE NOTE 1	SEE NOTE 1

REVISIONS	
NAME	DATE
BUREAU OF TRAFFIC	1/01/02

ILLINOIS DEPARTMENT OF TRANSPORTATION

DISTRICT 1
STANDARD TRAFFIC SIGNAL
DESIGN DETAILS

SCALE: NONE
DATE: 3/20/2007

DRAWN BY: RWP
DESIGNED BY: DAD
CHECKED BY: DAZ
SHEET 2 OF 4

TS05
REVISION DATE: 01/01/02

PLOT DATE = 3/20/2007
FILE NAME = C:\Users\dl00222\Documents\dl00222\ts05.dwg
PLOT SCALE = 50.0000 / 1.0000
USER NAME = steepp

F.A.P. RTE.	SECTION	COUNTY	TOTAL SHEETS	SHEET NO.
846	(4,4R,&5)RS-7	WILL	35	29
STA.	TO STA.			
FED. ROAD DIST. NO.	ILLINOIS FED. AID PROJECT			

CONTRACT NO. 62364

MATERIAL:
 - ASTM A48 CLASS 30 GREY IRON
 - ASTM A123 HOT DIPPED GALVANIZED

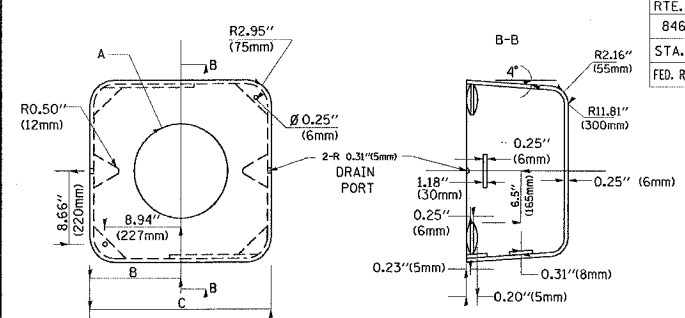

TYPE	A	B	C	HEIGHT	WEIGHT
I	Ø 10.125" (257mm)	9.5" (241mm)	19" (483mm)	12" (300mm)	24kg
II	Ø 11.125" (283mm)	10.75" (273mm)	21.5" (546mm)	12" (300mm)	26kg

SHROUD DETAIL

NOTE:
 SUPPORT EXISTING CABINET AND CONTROL EQUIPMENT ABOVE FOUNDATION TO KEEP TRAFFIC SIGNAL FUNCTIONING WHILE FOUNDATION MODIFICATION WORK IS PROCEEDING.

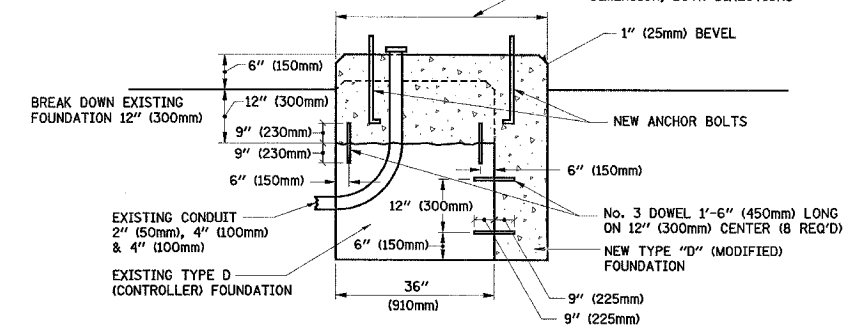

MODIFY EXISTING TYPE "D" FOUNDATION

(NOT TO SCALE)

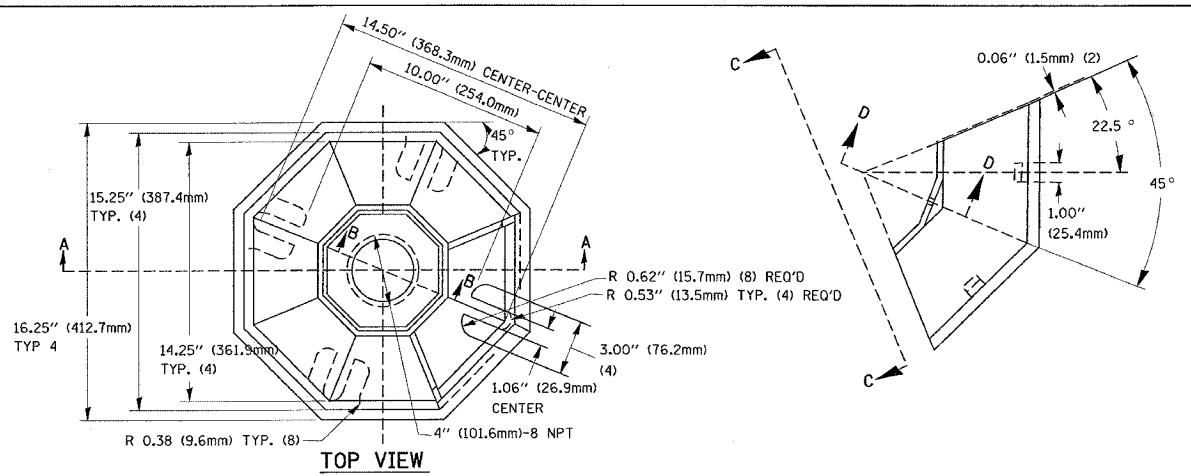

TOP VIEW

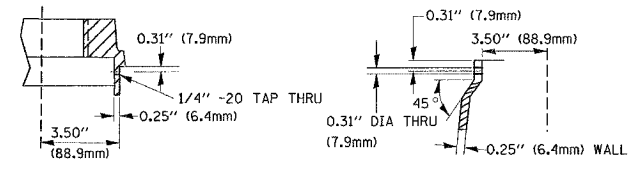

SECTION B-B

SECTION D-D

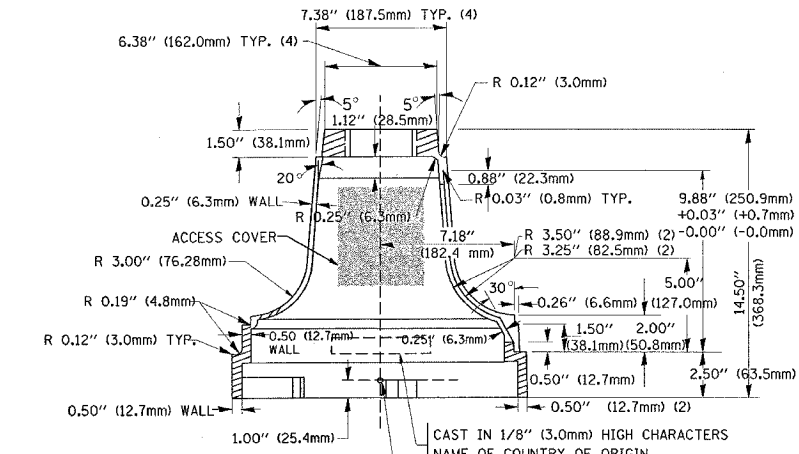

SECTION A-A

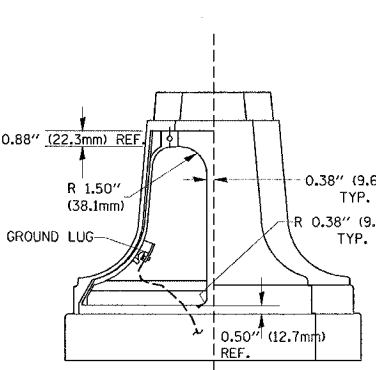

VIEW C-C

TRAFFIC SIGNAL POST - MOUNTING BASE - TYPE A

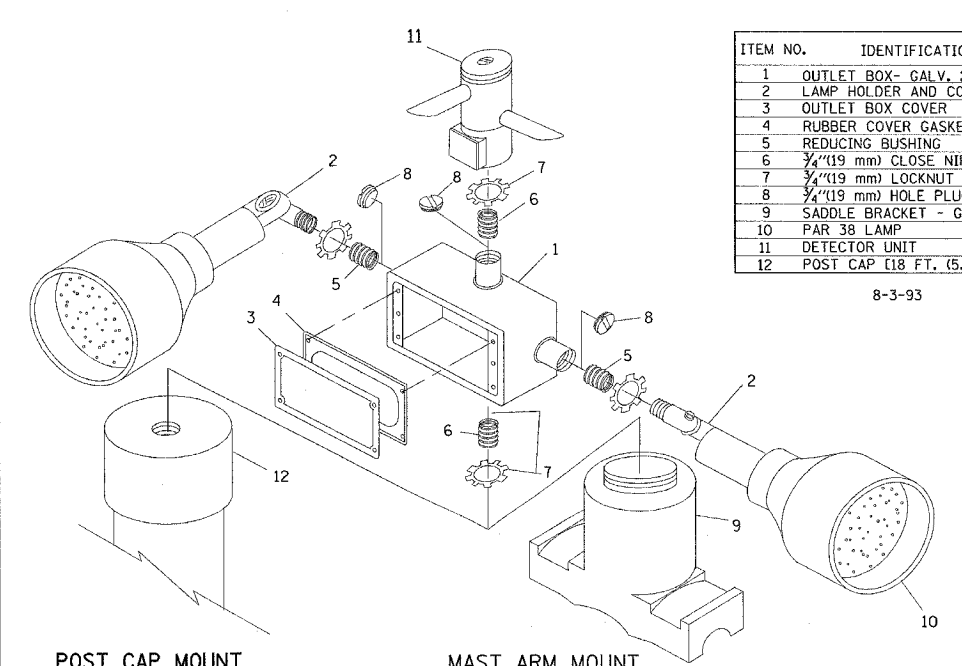

POST CAP MOUNT

MAST ARM MOUNT

EMERGENCY VEHICLE DETECTOR WITH CONFIRMATION BEACON MOUNTING DETAIL

ITEM NO.	IDENTIFICATION
1	OUTLET BOX - GALV. 21 CU. IN. (0.000344 CU-M)
2	LAMP HOLDER AND COVER
3	OUTLET BOX COVER
4	RUBBER COVER GASKET
5	REDUCING BUSHING
6	3/4" (19 mm) CLOSE NIPPLE
7	3/4" (19 mm) LOCKNUT
8	3/4" (19 mm) HOLE PLUG
9	SADDLE BRACKET - GALV.
10	PAR 38 LAMP
11	DETECTOR UNIT
12	POST CAP [18 FT. (5.4 m) POST MIN.]

8-3-93

NOTES:

- ALL ELECTRICAL ITEMS, EXCEPT ITEMS #2 AND #11 SHALL BE ALUMINUM OR GALVANIZED
- ITEM #1- OZ/GEDNEY FSX-1-50 OR EQUIVALENT
 ITEM #2- MULBERRY CON-O-SHADE LAMP SHIELD OR EQUIVALENT
 ITEM #9- "BAND-IT" SADDLE BRACKET OR EQUIVALENT
- WHEN POST MOUNTING IS SPECIFIED, ITEM #9 SHALL NOT BE REQUIRED. THE DETECTION UNIT SHALL BE MOUNTED DIRECTLY ON TOP OF THE CAP BY DRILLING AND TAPPING A 3/4" (19 mm) HOLE WITH PIPE THREADS. THE POST CAP SHALL EITHER BE SCREWED TO THE TOP OF THE POST OR A MINIMUM OF 3 TIGHTENING SCREWS SHALL BE REQUIRED ON EACH CAP.

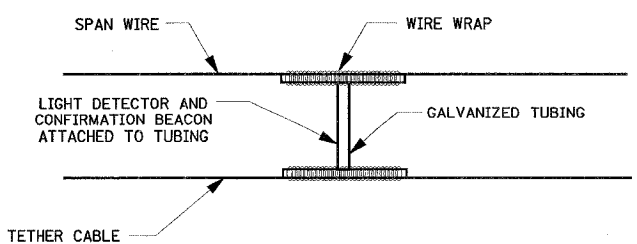

LIGHT DETECTOR AND CONFIRMATION BEACON MOUNTING FOR TEMPORARY TRAFFIC SIGNALS

(NOT TO SCALE)

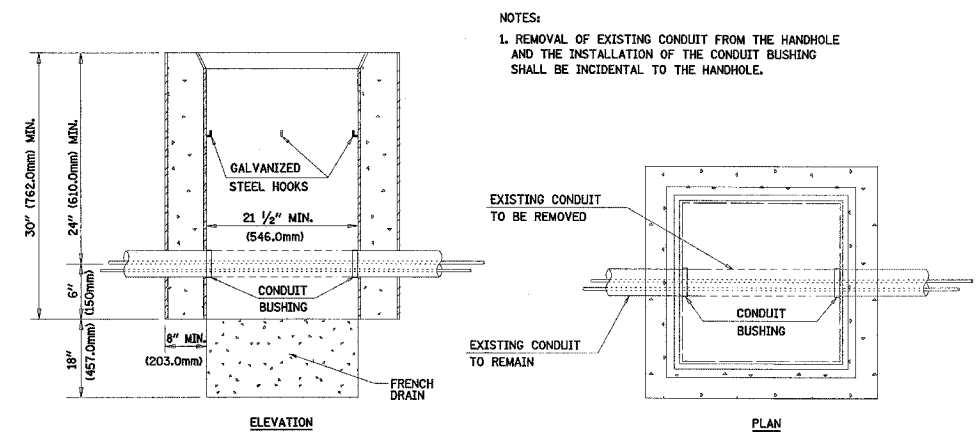

DETAIL HANDHOLE TO INTERCEPT EXISTING CONDUIT

N.T.S.

REVISIONS	
NAME	DATE
BUREAU OF TRAFFIC	5/30/00
BUREAU OF TRAFFIC	3/15/01
BUREAU OF TRAFFIC	11/12/01
BUREAU OF TRAFFIC	1-01-02

ILLINOIS DEPARTMENT OF TRANSPORTATION

DISTRICT ONE
 STANDARD TRAFFIC SIGNAL
 DESIGN DETAILS

SCALE: NONE
 DATE: 3/20/2007

DRAWN BY: RWP
 DESIGNED BY: DAZ
 CHECKED BY: DAZ
 SHEET 4 OF 4

TS05

REVISION DATE: 01/01/02

PLOT DATE = 3/20/2007
 FILE NAME = c:\p\projects\dl02022\dl02022.dwg
 PLOT SCALE = 1/8" = 1'-0"
 USER NAME = ssteele

P. & P. No.	SECTION	COUNTY	TOTAL SHEETS	SHEET NO.
846	(4,4R,&5) RS-T	WILL	35	31
STA. +	TO STA. +			
FED. ROAD DIST. NO. 1	ILLINOIS	FED. AID PROJECT		

62364

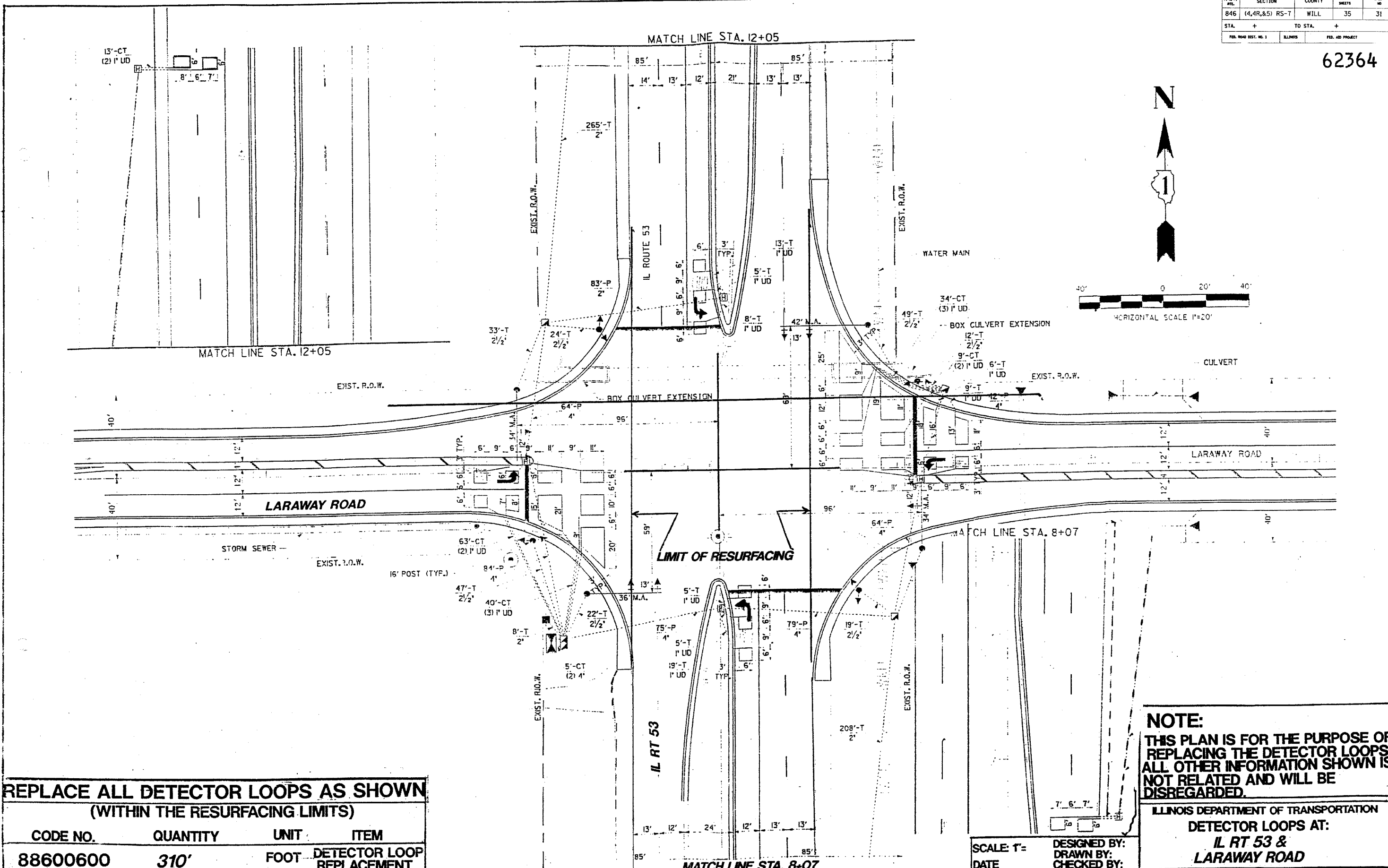

REPLACE ALL DETECTOR LOOPS AS SHOWN

(WITHIN THE RESURFACING LIMITS)

CODE NO.	QUANTITY	UNIT	ITEM
88600600	310'	FOOT	DETECTOR LOOP REPLACEMENT

NOTE:
 THIS PLAN IS FOR THE PURPOSE OF REPLACING THE DETECTOR LOOPS. ALL OTHER INFORMATION SHOWN IS NOT RELATED AND WILL BE DISREGARDED.

ILLINOIS DEPARTMENT OF TRANSPORTATION
 DETECTOR LOOPS AT:
 IL RT 53 &
 LARAWAY ROAD

SCALE: 1"= DATE
 DESIGNED BY: DRAWN BY: CHECKED BY:

P.L.P. NO.	SECTION	COUNTY	TOTAL SHEETS	SHEET NO.
846	(4,4R,8,5) RS-7	WILL	35	32
STA.	+	TO STA.	+	
FED. ROAD DIST. NO. 1	ILLINOIS	FED. AID PROJECT		

62364

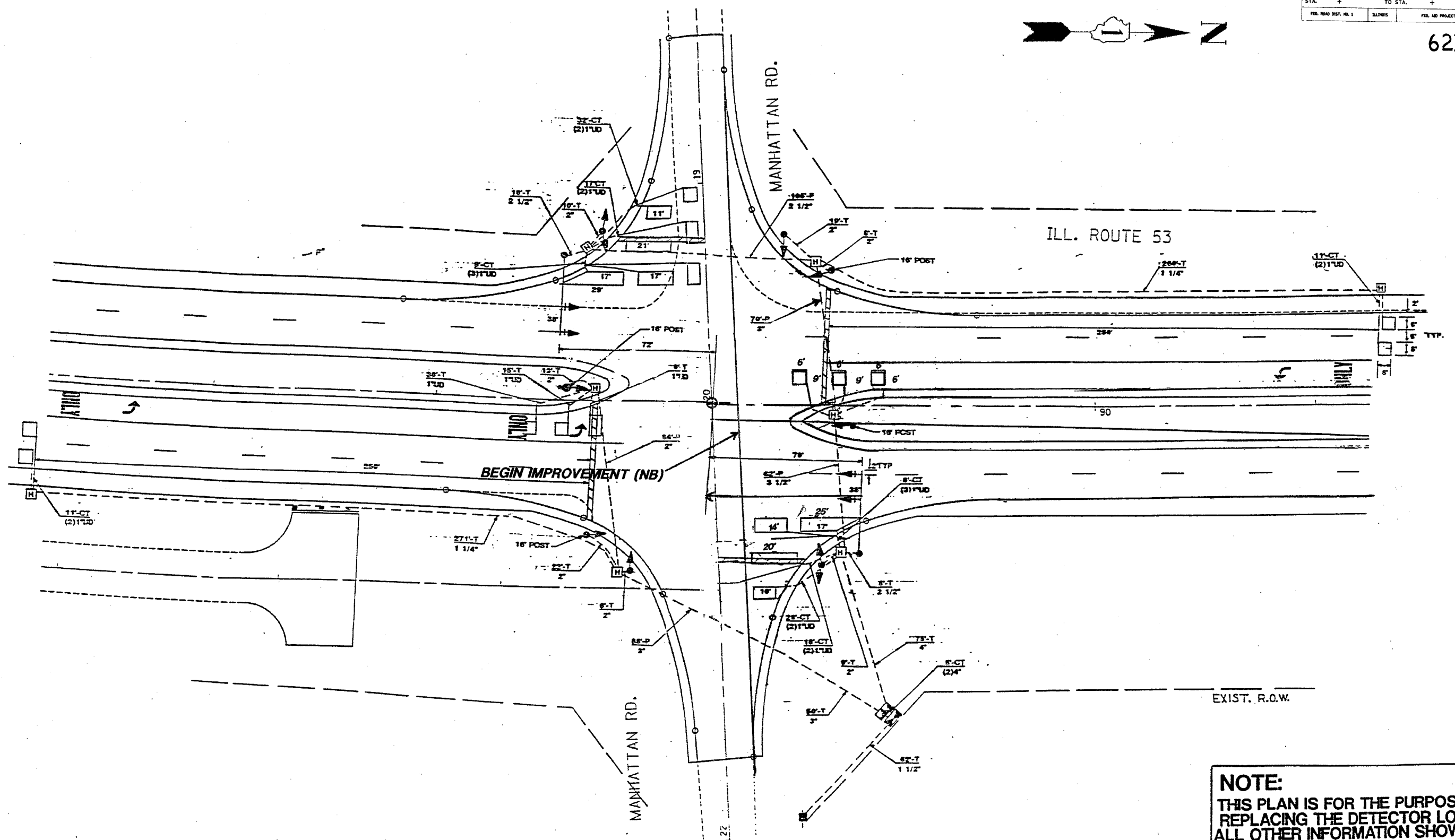

REPLACE ALL DETECTOR LOOPS AS SHOWN

(WITHIN THE RESURFACING LIMITS)

CODE NO.	QUANTITY	UNIT	ITEM
88600600	363'	FOOT	DETECTOR LOOP REPLACEMENT

NOTE:
 THIS PLAN IS FOR THE PURPOSE OF REPLACING THE DETECTOR LOOPS. ALL OTHER INFORMATION SHOWN IS NOT RELATED AND WILL BE DISREGARDED.



ILLINOIS DEPARTMENT OF TRANSPORTATION
 DETECTOR LOOPS AT:
IL RT 53 & MANHATTAN ROAD

SCALE: T=
 DATE DESIGNED BY:
 DRAWN BY:
 CHECKED BY:

F.A.P. RTE.	SECTION	COUNTY	TOTAL SHEETS	SHEET NO.
846	4, 4R & 5) RS-7	WILL	35	33
STA.	TO STA.			
FED. ROAD DIST. NO.	ILLINOIS	FED. AID PROJECT		

SHEET 31 OF 32

CONTRACT NO. 62364

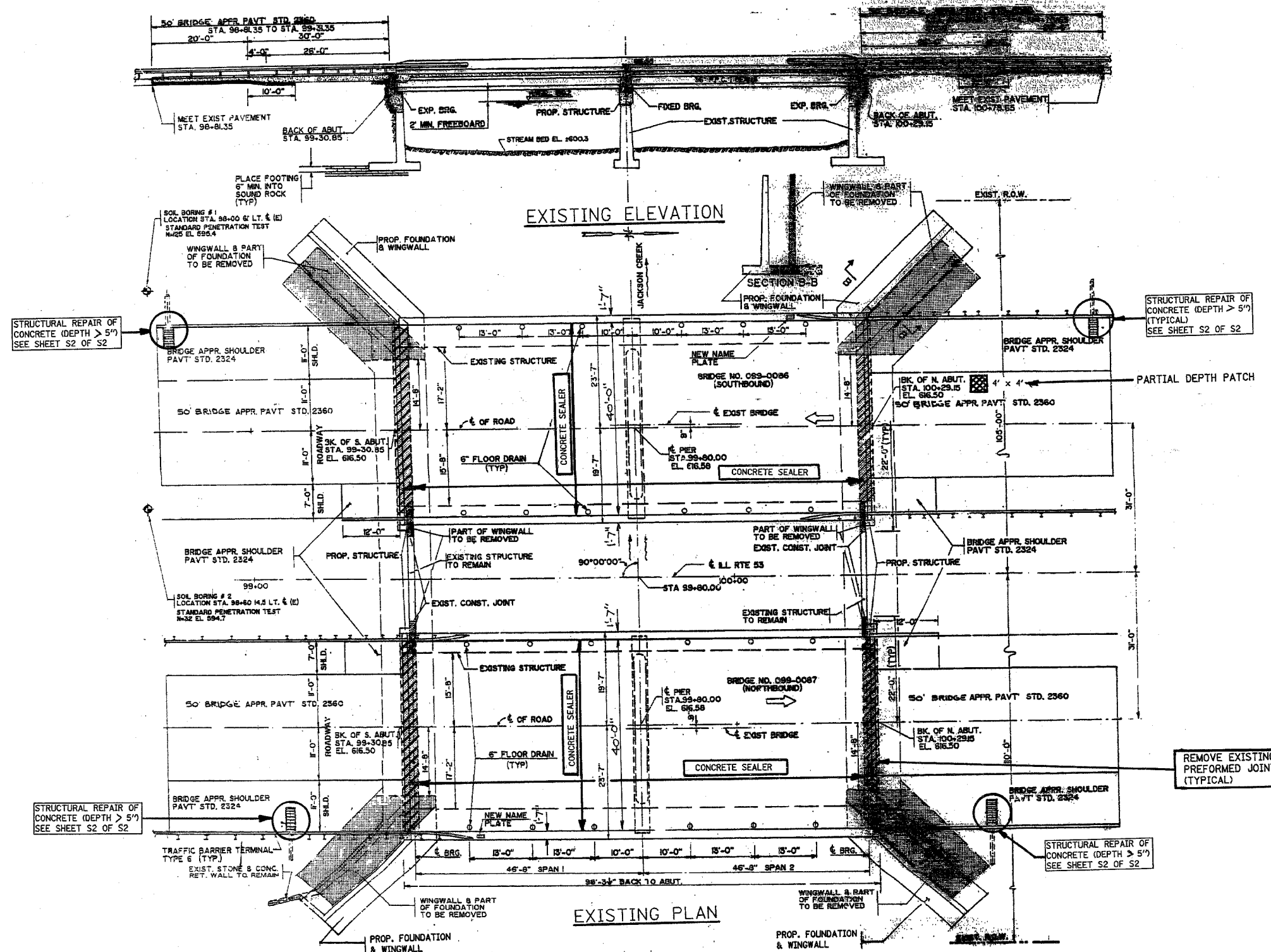

NOTES:

PLAN DIMENSIONS AND DETAILS RELATIVE TO EXISTING PLANS ARE SUBJECT TO ROUTINE VARIATIONS. THE CONTRACTOR SHALL FIELD VERIFY EXISTING DIMENSIONS AND DETAILS AFFECTING NEW CONSTRUCTION AND MAKE NECESSARY APPROVED ADJUSTMENTS PRIOR TO CONSTRUCTION OR ORDERING OF MATERIALS. SUCH VARIATIONS SHALL NOT BE CAUSE FOR ADDITIONAL COMPENSATION FOR A CHANGE IN SCOPE OF THE WORK, HOWEVER, THE CONTRACTOR WILL BE PAID FOR THE QUANTITY ACTUALLY FURNISHED BASED UPON THE UNIT PRICE BID FOR THE WORK.

SCOPE OF WORK:

1. STRUCTURAL REPAIR OF CONCRETE AT APPROACHES AND NORTH ABUTMENT WALL.
2. CONCRETE SEALER (DECK)
3. PJS REPLACEMENT WITH SILICONE JOINT SEAL AT ABUTMENTS. APPROACH SLAB REPAIR.

PLOT DATE = 5/1/2007
 PLOT SCALE = 5/8" = 1' IN.
 USER NAME = tunkosey

REVISIONS		ILLINOIS DEPARTMENT OF TRANSPORTATION
NAME	DATE	
		ILL - 53 OVER JACKSON CREEK GENERAL PLAN AND ELEVATION S.N. 099-0086 SB AND S.N. 099-0087 NB SCALE: VERT. _____ HORIZ. _____ DATE: MAY, 2007
DRAWN BY: MVT		CHECKED BY: _____
DATE: MAY, 2007		

F.A. RTE.	SECTION	COUNTY	TOTAL SHEETS	SHEET NO.
4,4R & 5) RS-7	WILL		35	34
STA.		TO STA.		
FED. ROAD DIST. NO.	ILLINOIS	FED. AID PROJECT		

SHEET S2 OF S2

CONTRACT NO. 62364
D-91-002-02

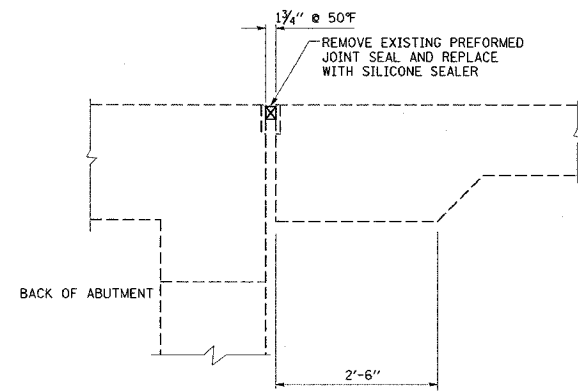

EXISTING TRANSVERSE JOINT
NORTH AND SOUTH ABUTMENTS

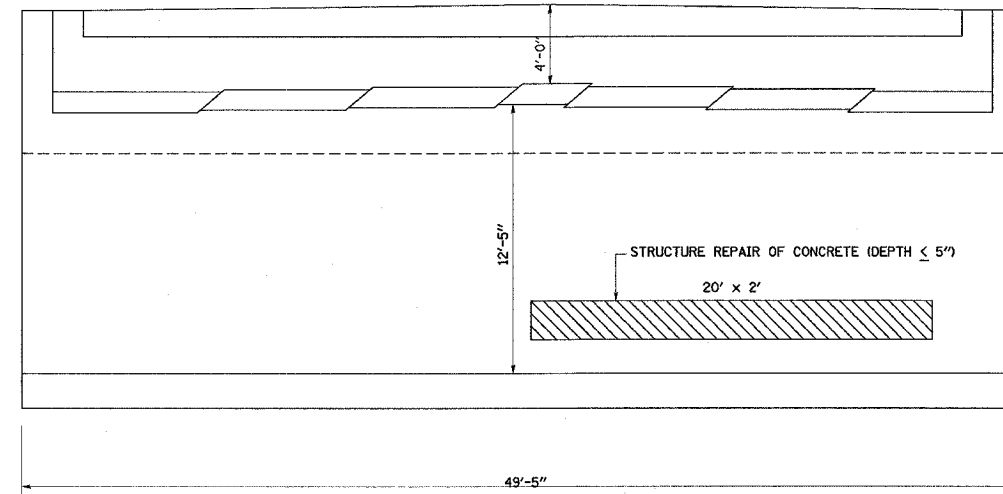

NORTH ABUTMENT

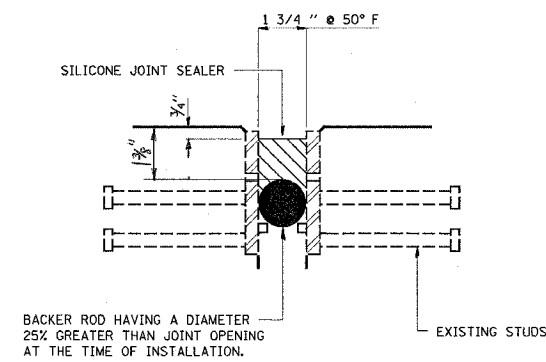

SILICONE JOINT SEAL TO REPLACE
2 1/2" PREFORMED JOINT SEAL

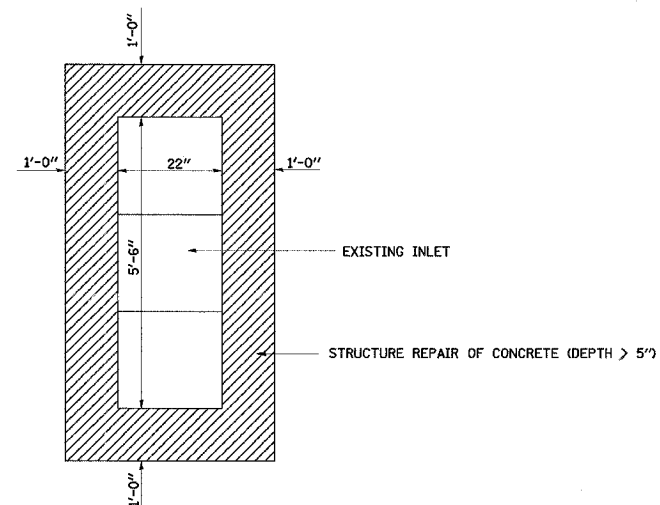

STRUCTURE REPAIR OF CONCRETE
AROUND DRAINAGE INLET
(4 LOCATIONS SEE SHEET S1 OF S2)

BILL OF MATERIALS

ITEM	UNIT	QUANTITY
SILICONE JOINT SEALER	FOOT	172
CONCRETE SEALER	SQ. FT.	7360
APPROACH SLAB REPAIR (PARTIAL DEPTH)	SQ. YD.	2
STRUCTURE REPAIR OF CONCRETE (DEPTH > 5')	SQ. FT.	75
STRUCTURE REPAIR OF CONCRETE (DEPTH <= 5')	SQ. FT.	40

LEGEND:

- STRUCTURE REPAIR OF CONCRETE (DEPTH <= 5')
- STRUCTURE REPAIR OF CONCRETE (DEPTH > 5')

REVISIONS	
NAME	DATE

ILLINOIS DEPARTMENT OF TRANSPORTATION

ILL 53 OVER
JACKSON CREEK
NORTH ABUTMENT AND DETAILS
S.N. 099-0086 SB AND
S.N. 099-0087 NB
SCALE: VERT. DRAWN BY: MVT
 HORIZ. DATE: MAY, 2007 CHECKED BY: RSS

PLOT DATE = 6/1/2007
FILE NAME = c:\p\projects\struct1\099-0086.dgn
PLOT SCALE = 1/8" = 1'-0"
USER NAME = tuncakosny

F.A.P. RTE.	SECTION	COUNTY	TOTAL SHEETS	SHEET NO.
846	(4,4R,&5)RS-7	WILL	35	35
STA.		TO STA.		
FED. ROAD DIST. NO.	ILLINOIS	FED. AID PROJECT	CONTRACT NO. 62364	

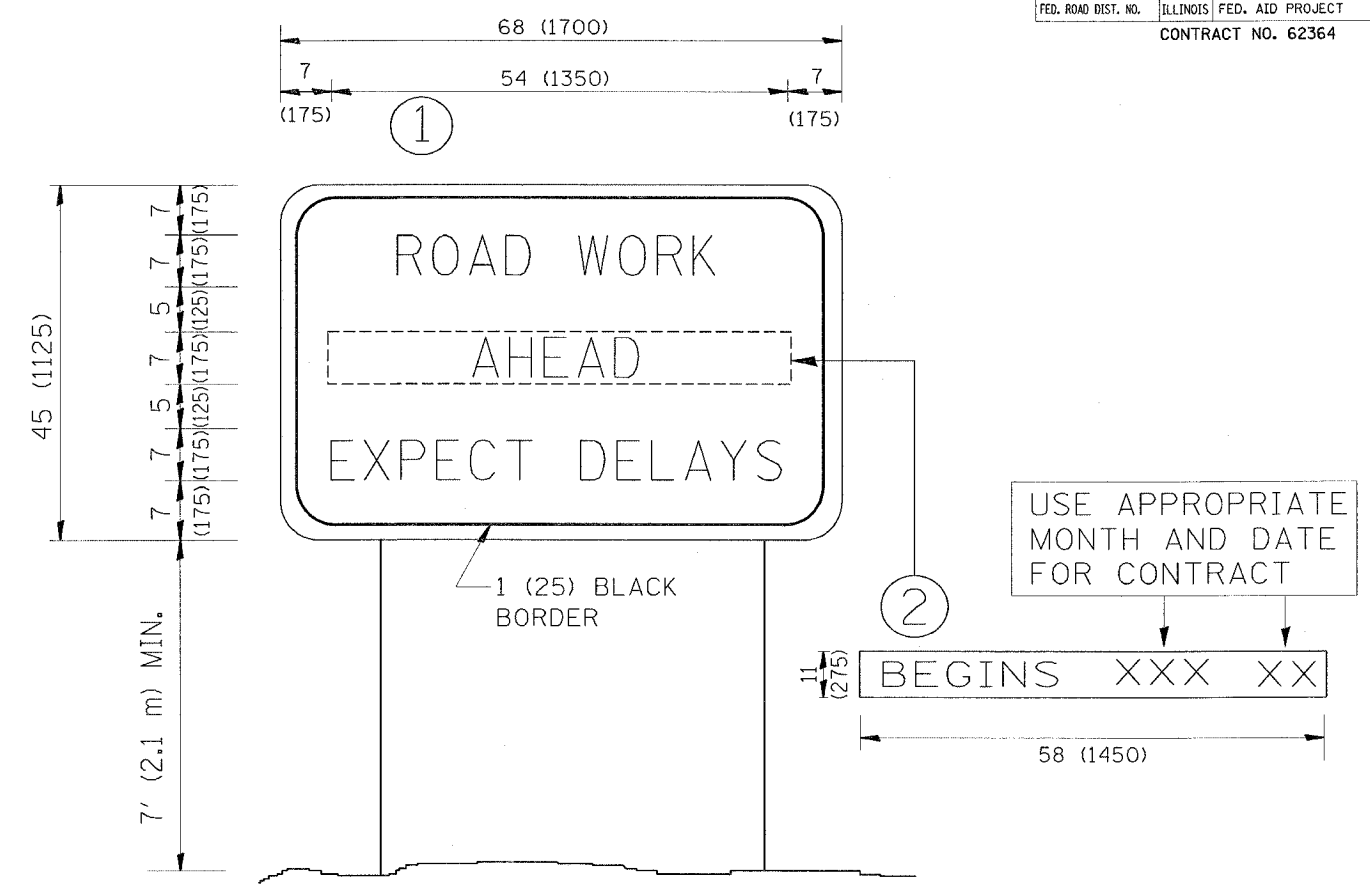

NOTES:

1. USE BLACK LETTERING ON ORANGE BACKGROUND.
2. ERECT SIGNS IN ADVANCE OF THE LOCATION FOR THE "ROAD CONSTRUCTION AHEAD" SIGN AT LOCATIONS AS DIRECTED BY THE ENGINEER.
3. ERECT SIGN ① WITH INSTALLED PANEL ② ONE WEEK PRIOR TO THE START OF CONSTRUCTION.
4. REMOVE PANEL ② SOON AFTER THE START OF CONSTRUCTION.
5. SEE SPECIAL PROVISION FOR "TEMPORARY INFORMATION SIGNING" FOR ADDITIONAL INFORMATION.
6. ONE SIGN ASSEMBLY EQUALS 25.70 SQ. FT. (2.3 SQ. M.)
7. SHALL BE PAID FOR AS TEMPORARY INFORMATION SIGNING.

ALL DIMENSIONS ARE IN INCHES (MILLIMETERS) UNLESS OTHERWISE SHOWN.

REVISIONS	
NAME	DATE
R. MIRS	9-15-97
R. MIRS	12-11-97
T. RAMMACHER	2-2-99
C. JUCIUS	1-31-07

ILLINOIS DEPARTMENT OF TRANSPORTATION
**ARTERIAL ROAD
INFORMATION SIGN**

SCALE: NONE

DRAWN BY DESIGN
CHECKED BY

TC22

PLOT DATE = 3/20/2007
PLOT SCALE = 3/8" = 1'-0"
USER NAME = standpa