

F.A.P. RTE.	SECTION	COUNTY	TOTAL SHEETS	SHEET NO.
820	*	DOUGLAS	57	45

\*(37,37-1,2&3)RS-1

### PRIVATE ENTRANCE AND COMMERCIAL ENTRANCE HMA SURFACE REMOVAL-BUTT JOINT (HMA OR OIL & CHIP)

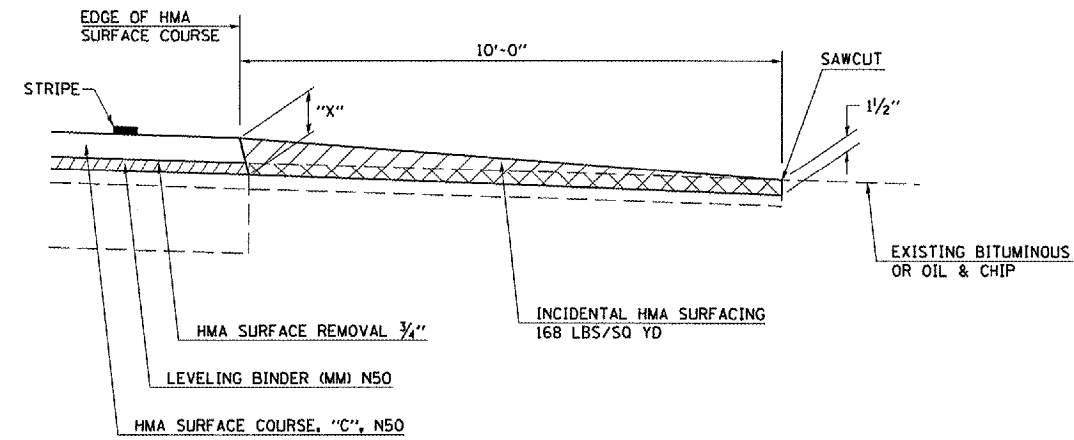

NOTES: THE INCIDENTAL HMA SURFACING IS INTENDED TO RESURFACE THE EXISTING ENTRANCES IN THEIR ENTIRETY.

"X" = PROPOSED RESURFACING THICKNESS

### FIELD ENTRANCE (HMA OR OIL & CHIP)

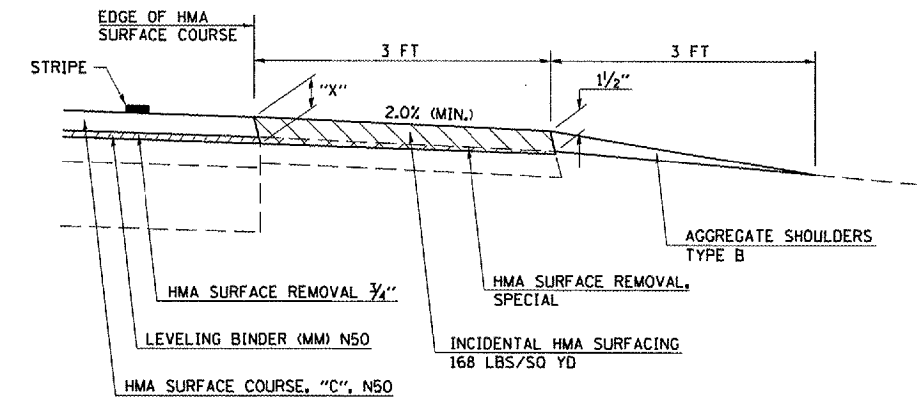

NOTES: THE INCIDENTAL HMA SURFACING IS INTENDED TO RESURFACE THE EXISTING ENTRANCES IN THEIR ENTIRETY.

"X" = PROPOSED RESURFACING THICKNESS

### PRIVATE AND COMMERCIAL ENTRANCE (AGGREGATE OR EARTH)

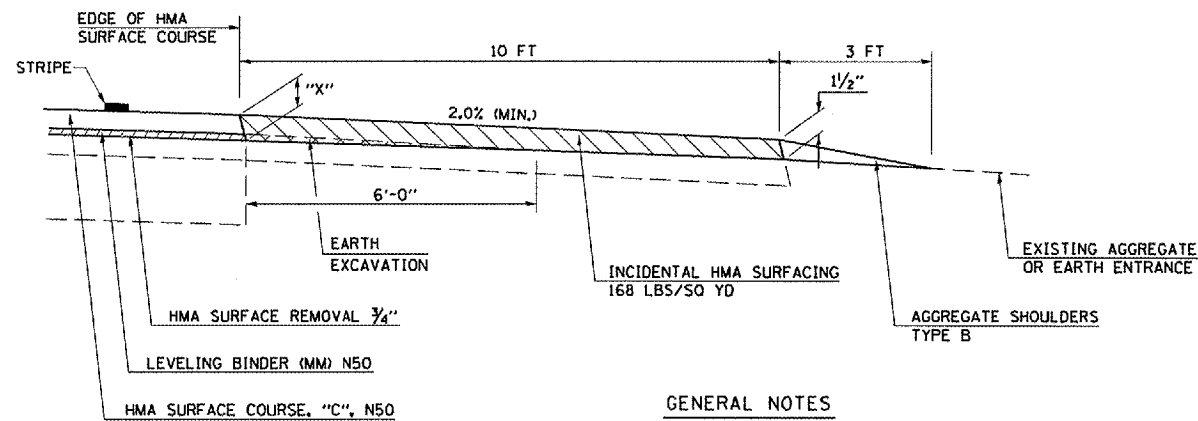

#### GENERAL NOTES

1. EARTH EXCAVATION WILL NOT BE MEASURED FOR PAYMENT. THE EXISTING SURFACE SHALL BE PREPARED IN ACCORDANCE WITH SECTION 408 OF THE STANDARD SPECIFICATIONS.
2. THE INCIDENTAL HMA SURFACING IS INTENDED TO RESURFACE THE EXISTING ENTRANCES IN THEIR ENTIRETY.
3. ANY NECESSARY WORK BEHIND THE INCIDENTAL HMA SURFACING SHALL BE AS SHOWN IN THE PLANS AND/OR AS DIRECTED BY THE ENGINEER.
4. "X" = PROPOSED RESURFACING THICKNESS

### MAILBOX TURNOUTS (HMA OR OIL & CHIP)

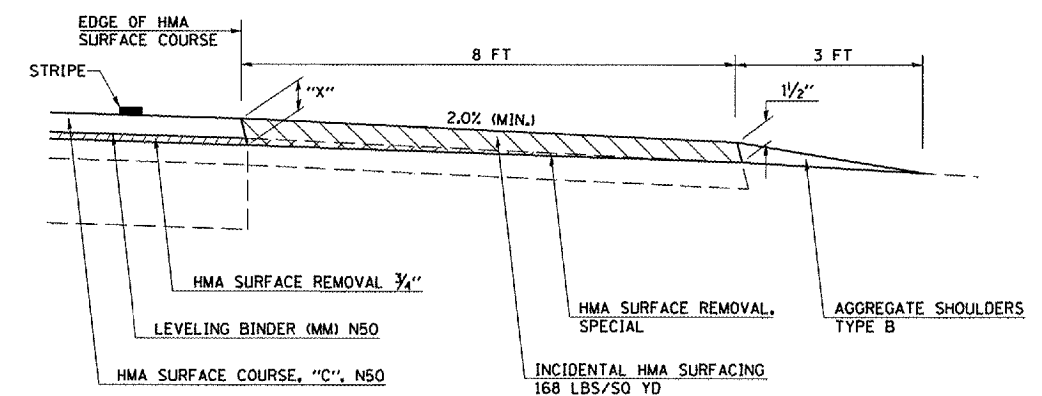

NOTES: THE INCIDENTAL HMA SURFACING IS INTENDED TO RESURFACE THE EXISTING MAILBOX TURNOUTS IN THEIR ENTIRETY.

"X" = PROPOSED RESURFACING THICKNESS