

F.A. RTE.	SECTION	COUNTY	TOTAL SHEETS	SHEET NO.
2545	98-00036-19-FP	WILL	147	118
STA.		TO STA.		
FED. ROAD DIST. NO.		ILLINOIS FED. AID PROJECT		

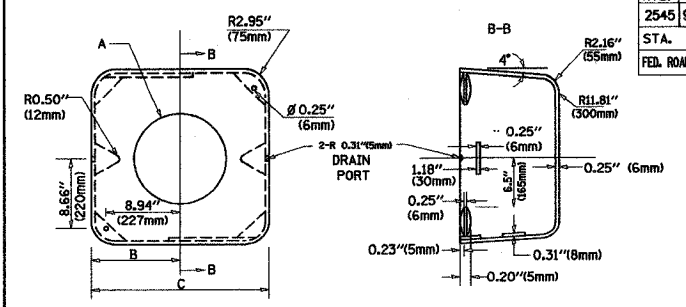

TYPE	A	B	C	HEIGHT	WEIGHT
I	Ø 10.125\"(257mm)	9.5\"(241mm)	19\"(483mm)	12\"(300mm)	24kg
II	Ø 11.125\"(283mm)	10.75\"(273mm)	21.5\"(546mm)	12\"(300mm)	26kg

MATERIAL:
 - ASTM A48 CLASS 30 GREY IRON
 - ASTM A123 HOT DIPPED GALVANIZED

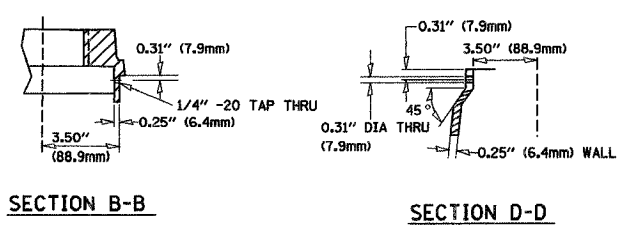
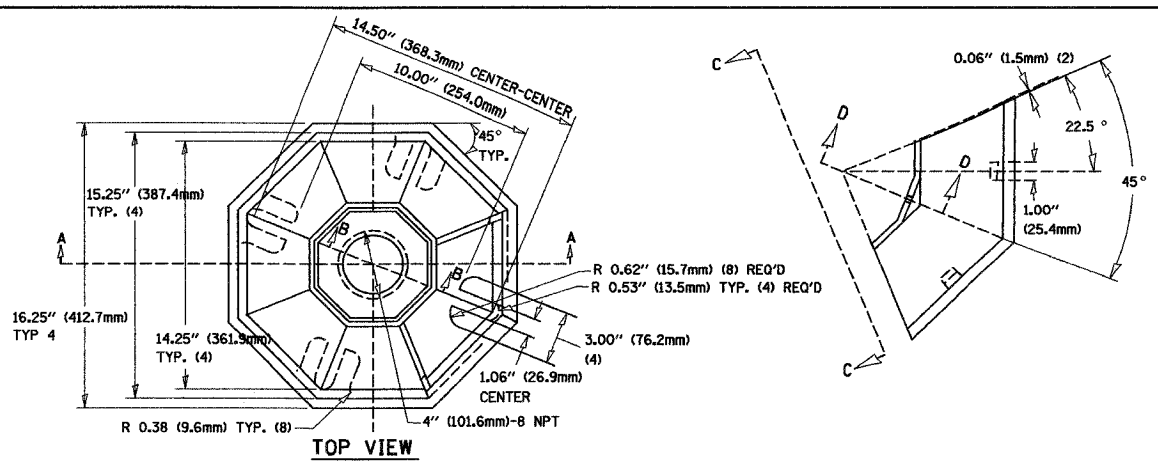
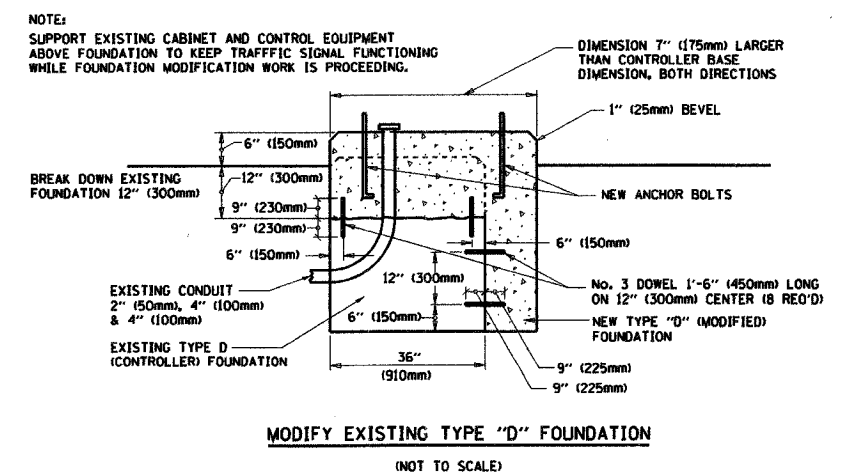
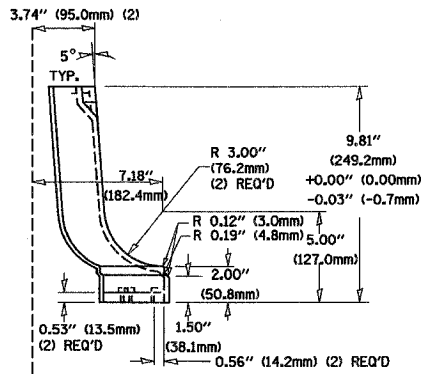
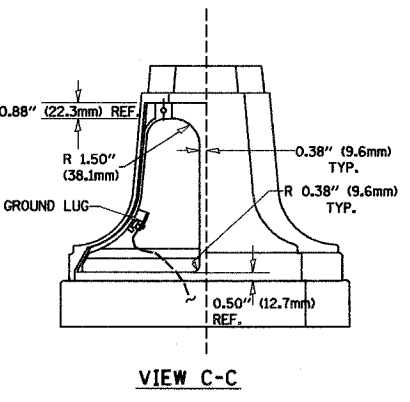
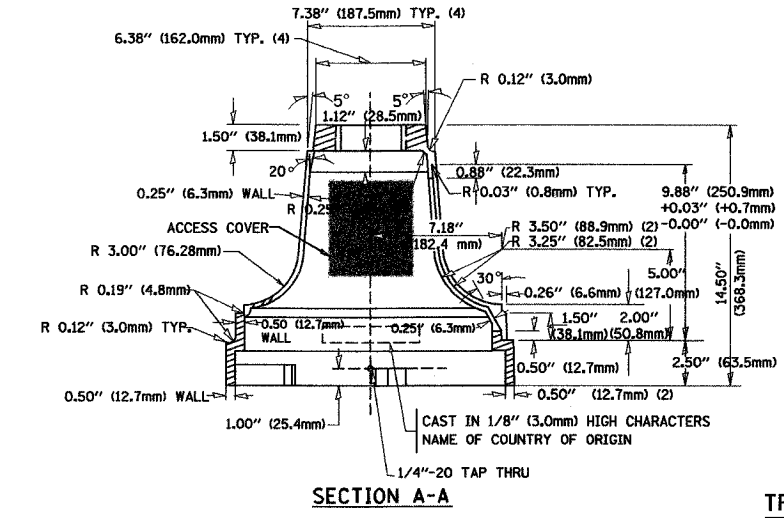

NOTE:
 SUPPORT EXISTING CABINET AND CONTROL EQUIPMENT ABOVE FOUNDATION TO KEEP TRAFFIC SIGNAL FUNCTIONING WHILE FOUNDATION MODIFICATION WORK IS PROCEEDING.

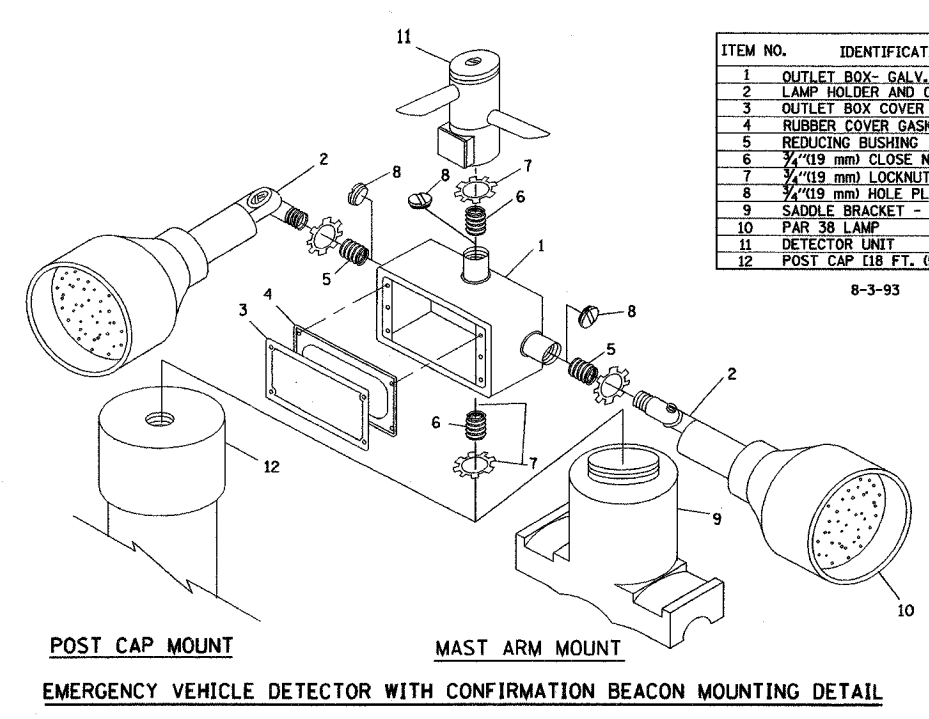

ITEM NO.	IDENTIFICATION
1	OUTLET BOX- GALV. 21 CU.IN. (0.000344 CU-M)
2	LAMP HOLDER AND COVER
3	OUTLET BOX COVER
4	RUBBER COVER GASKET
5	REDUCING BUSHING
6	3/4\"(19 mm) CLOSE NIPPLE
7	3/4\"(19 mm) LOCKNUT
8	3/4\"(19 mm) HOLE PLUG
9	SADDLE BRACKET - GALV.
10	PAR 38 LAMP
11	DETECTOR UNIT
12	POST CAP [18 FT. (5.4 m) POST MIN.]

NOTES:
 1. ALL ELECTRICAL ITEMS, EXCEPT ITEMS #2 AND #11 SHALL BE ALUMINUM OR GALVANIZED
 2. ITEM #1- OZ/GEDNEY FSX-1-50 OR EQUIVALENT
 ITEM #2- MULBERRY CON-O-SHADE LAMP SHIELD OR EQUIVALENT
 ITEM #9- "BAND-IT" SADDLE BRACKET OR EQUIVALENT
 3. WHEN POST MOUNTING IS SPECIFIED, ITEM #9 SHALL NOT BE REQUIRED. THE DETECTION UNIT SHALL BE MOUNTED DIRECTLY ON TOP OF THE CAP BY DRILLING AND TAPPING A 3/4\"(19 mm) HOLE WITH PIPE THREADS. THE POST CAP SHALL EITHER BE SCREWED TO THE TOP OF THE POST OR A MINIMUM OF 3 TIGHTENING SCREWS SHALL BE REQUIRED ON EACH CAP.

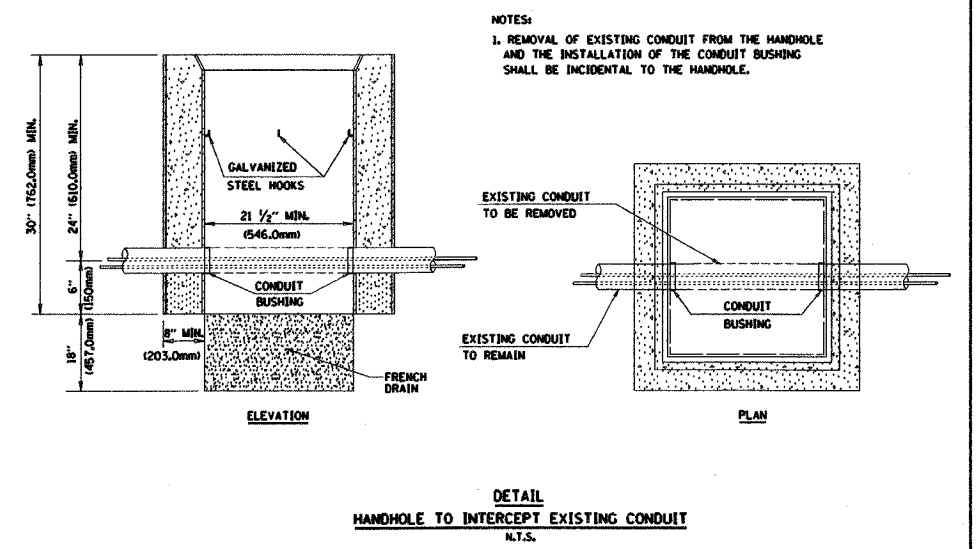
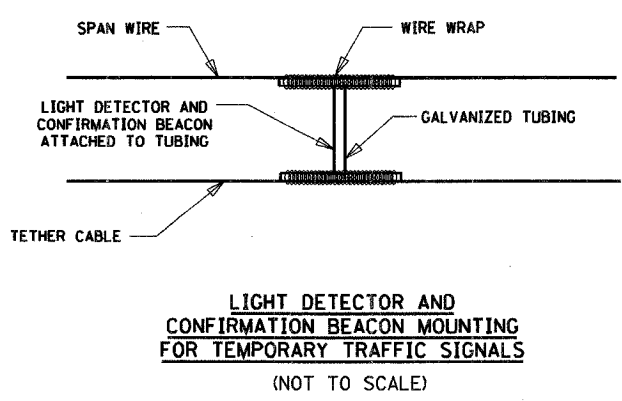

REVISIONS	NAME	DATE
	BUREAU OF TRAFFIC	5/30/00
	BUREAU OF TRAFFIC	3/15/01
	BUREAU OF TRAFFIC	11/12/01
	BUREAU OF TRAFFIC	1-01-02

ILLINOIS DEPARTMENT OF TRANSPORTATION
 DISTRICT ONE
 STANDARD TRAFFIC SIGNAL
 DESIGN DETAILS

SCALE: NONE
 DATE: 2/15/2006
 DRAWN BY: RWP
 DESIGNED BY: DAD
 CHECKED BY: DAZ
 SHEET 4 OF 4
 TS05
 REVISION DATE: 01/01/02

PLOT DATE = 2/15/2006
 FILE NAME = m:\data\ts\veg\tdp
 PLOT SCALE = 1/8\"/>