

F.A.P. RTE.	SECTION	COUNTY	TOTAL SHEETS	SHEET NO.
95	*	EFFINGHAM	409	149
FED. ROAD DIST. NO. 7 ILLINOIS FED. AID PROJECT				
*(6,7)Y, RS-1, 6B-1, 7B-1 & 7BR-2				
CONTRACT NO. 94356				

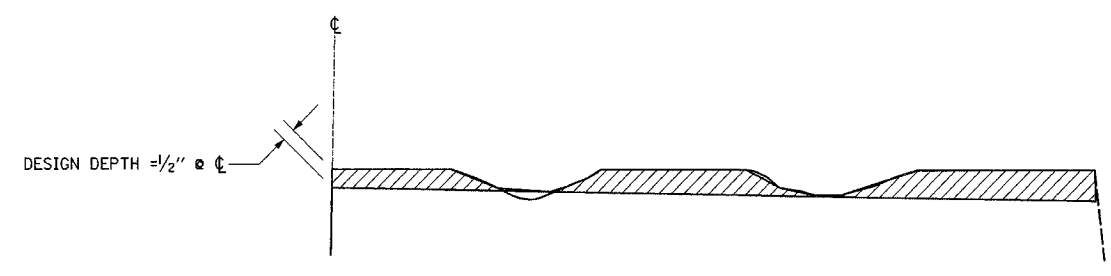

NOTES:

1. MILLING SHALL BE DONE TO ATTAIN REQUIRED SLOPE IN CROWN SECTIONS
2. EXISTING S.E. AND S.E. TRANSITIONS SHALL BE MAINTAINED UNLESS OTHERWISE SHOWN ON THE PLANS.
3. MILLING TO THE BOTTOM OF WHEEL RUTS SHALL NOT BE NECESSARY UNLESS REQUIRED TO OBTAIN SLOPE OR THE DESIGN DEPTH AT CENTERLINE.
4. THE AVERAGE DEPTH OF MILLING IS ESTIMATED TO BE 1/2" BUT MAY VARY IN ISOLATED LOCATIONS.

BITUMINOUS SURFACE REMOVAL (VARIABLE DEPTH) DETAIL

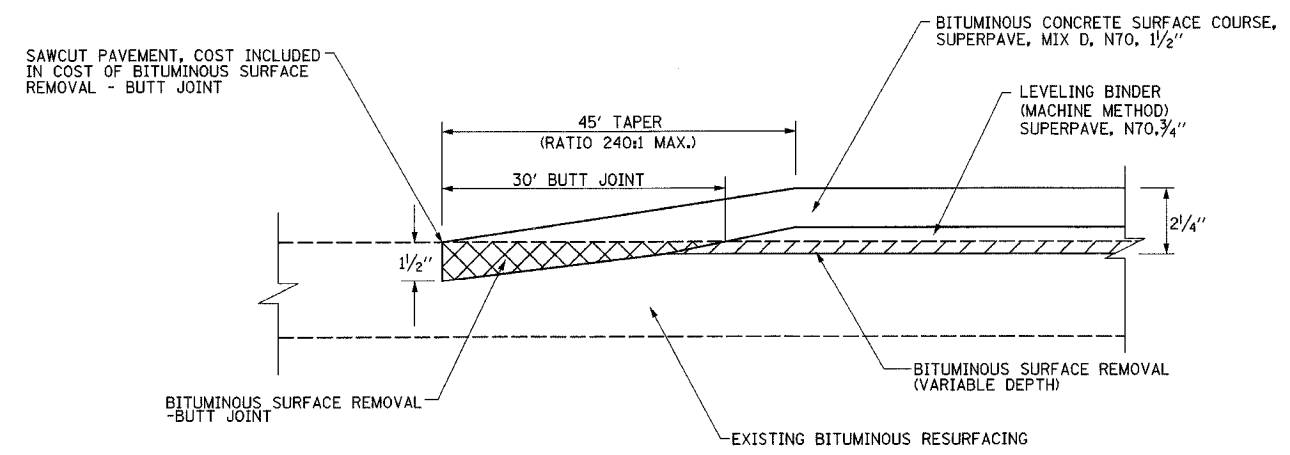

NOTE: MAINLINE BUTT JOINT SHOWN, 1775th STREET SIMILAR.

- BITUMINOUS SURFACE REMOVAL - BUTT JOINT
- BITUMINOUS SURFACE REMOVAL (VARIABLE DEPTH)

BITUMINOUS SURFACE REMOVAL-BUTT JOINT DETAIL

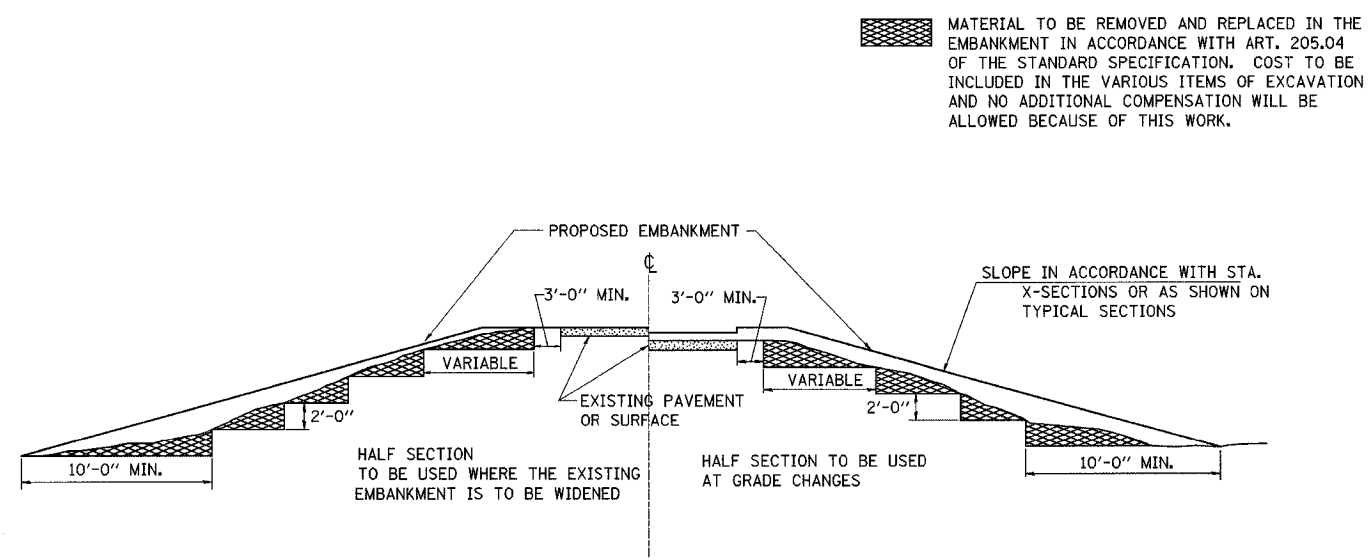

TYPICAL CROSS SECTION SHOWING STEP CONSTRUCTION ON EXISTING FILL

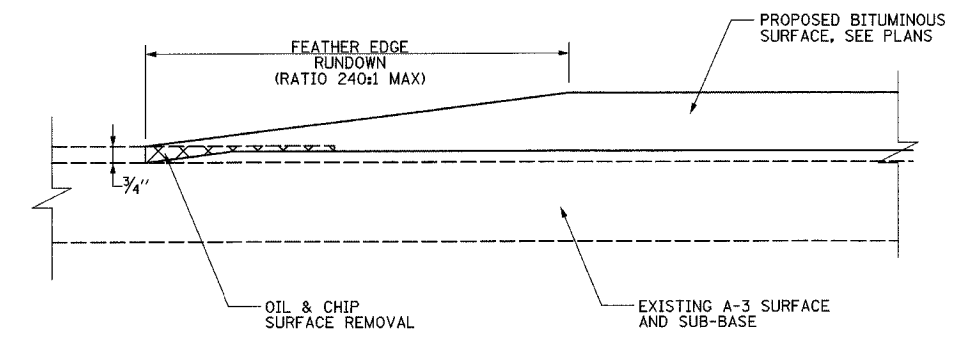

FEATHER EDGE RUNDOWN DETAIL

REVISIONS	
NAME	DATE

ILLINOIS DEPARTMENT OF TRANSPORTATION
ROADWAY DETAILS
DRAWN BY DIST. 7
CHECKED BY BWC
DATE 6/02