

LEGEND:

- ① PORTLAND CEMENT CONCRETE PAVEMENT, JOINTED 9 1/2"
 - ② SUB-BASE GRANULAR MATERIAL, TYPE A 12 1/2"
 - ③ AGGREGATE SURFACE COURSE, TYPE A 8"
 - ④ AGGREGATE BASE COURSE, TYPE A
 - ⑤ AGGREGATE SHOULDERS TYPE B, 6"
 - ⑥ HOT MIX ASPHALT PAVEMENT (FULL-DEPTH), 12 1/4"
 - ⑦ HOT MIX ASPHALT SURFACE CSE. "MIX D", N50 1 3/4"
 - ⑧ HOT MIX ASPHALT BINDER CSE. IL-19.0, N50 2 1/2"
 - ⑨ HOT MIX ASPHALT SHOULDERS, 8"
 - ⑩ LIME MODIFIED SOIL, 12"
 - ⑪ PORTLAND CEMENT CONCRETE SIDEWALK, 4"
 - ⑫ TOPSOIL FURNISH AND PLACE, 4"
 - ⑬ COMBINATION CONCRETE CURB & GUTTER, TYPE B-6.24
 - ⑭ COMBINATION CONCRETE CURB & GUTTER, TYPE B-6.18
 - ⑮ COMBINATION CONCRETE CURB & GUTTER, TYPE B-6.12
 - ⑯ COMBINATION CONCRETE CURB & GUTTER, TYPE B-6.06
 - ⑰ CONCRETE MEDIAN, TYPE SB-6
 - ⑱ CONCRETE MEDIAN SURFACE, 4"
 - ⑲ NO. 6 EPOXY COATED TIE BARS IN ACCORDANCE WITH STANDARD 420101, SECTION 420 OF THE STANDARD SPECIFICATIONS AND THE FOLLOWING TABLE:
- | LONGITUDINAL JOINT TYPE | BAR SIZE | SPACING |
|-------------------------|----------|---------|
| SAWED CONSTRUCTION | NO. 6 | 30" |
| | NO. 6 | 24" |
- ⑳ NO. 6 EPOXY COATED TIE BARS AT 24" CENTERS IN ACCORDANCE WITH STANDARD 606001
 - ㉑ BITUMINOUS MATERIALS (PRIME COAT)
 - ㉒ PAVEMENT MARKINGS (SEE PAVEMENT MARKING PLANS FOR TYPE AND LOCATIONS)
 - ㉓ HOT MIX ASPHALT SURFACE REMOVAL, VARIABLE DEPTH
 - ㉔ LEVELING BINDER, (MACHINE METHOD), N50 2 1/4"
 - ㉕ PORTLAND CEMENT CONCRETE PAVEMENT JOINTED 8 1/2" (UNREINFORCED)
 - ㉖ BITUMINOUS SURFACE TREATMENT, CLASS A-3
 - ㉗ PAVEMENT FABRIC

NOTE:
DOWEL AND TIES BARS SHALL NOT BE PAID FOR SEPARATELY BUT SHALL BE INCLUDED IN THE COST OF CONCRETE PAVEMENT AND/OR CONCRETE CURB AND GUTTER.

REVISIONS	
NAME	DATE

ILLINOIS DEPARTMENT OF TRANSPORTATION
TYPICAL SECTIONS
42ND STREET
VETERANS MEMORIAL DRIVE INTERCHANGE
SECTION (41-3)HBK
SCALE: NO SCALE
DATE 3-22-07
DRAWN BY RLT
CHECKED BY MTM

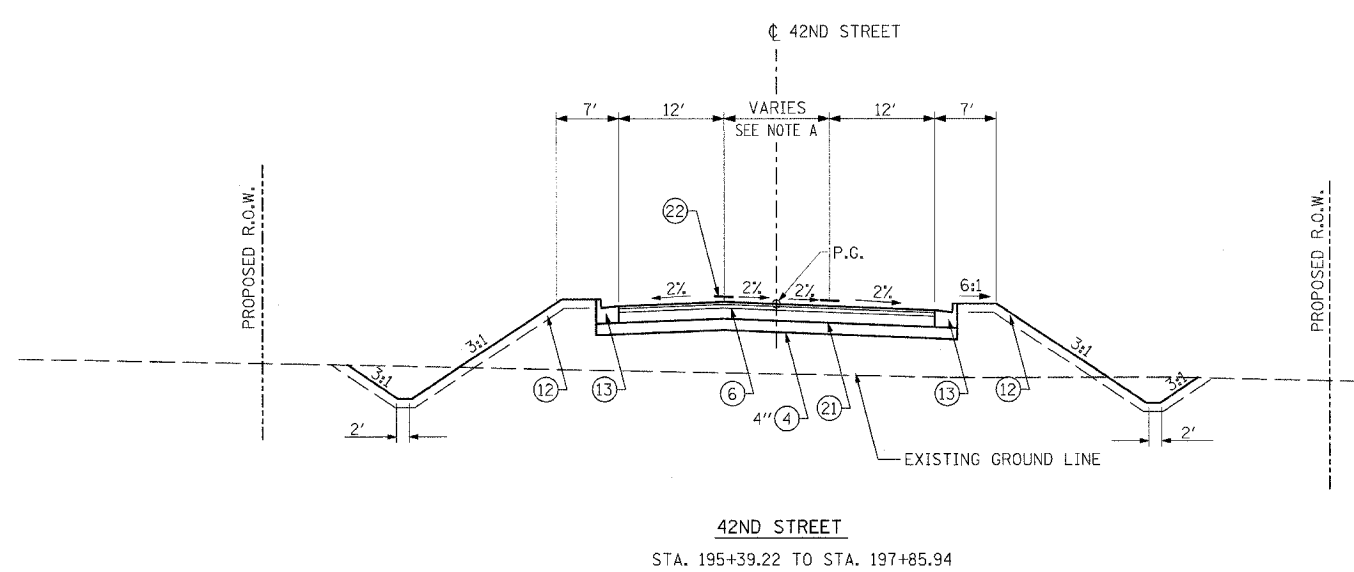

NOTE A:
MEDIAN TRANSITIONS FROM 15' AT STA. 195+81.70 TO 12.00' AT STA. 197+87.18, SEE PLAN SHEET.

STA 192+15.22 TO STA 193+85.34 SEE INTERSECTION DETAILS FOR PAVEMENT ELEVATIONS.

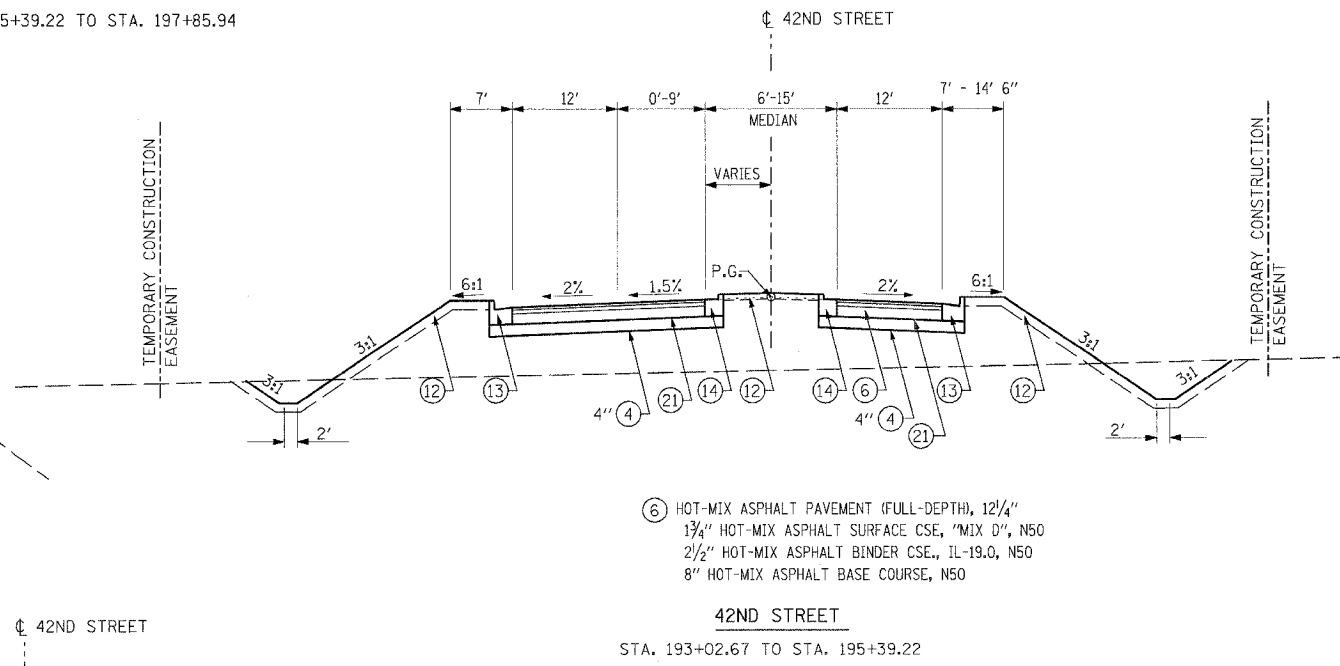
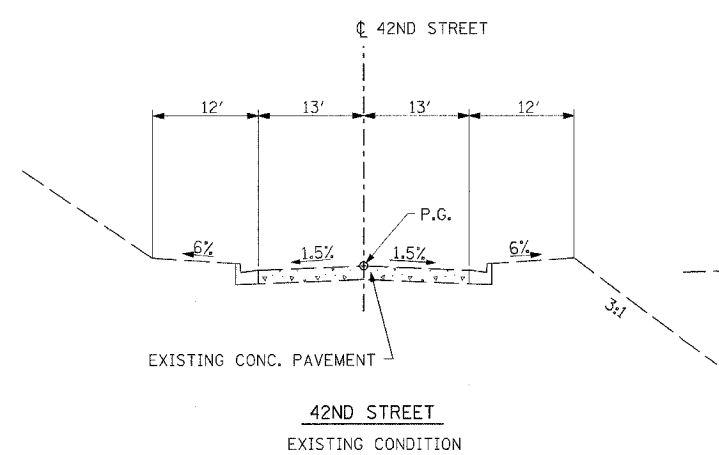

⑥ HOT-MIX ASPHALT PAVEMENT (FULL-DEPTH), 12 1/4"
1 3/4" HOT-MIX ASPHALT SURFACE CSE, "MIX D", N50
2 1/2" HOT-MIX ASPHALT BINDER CSE., IL-19.0, N50
8" HOT-MIX ASPHALT BASE COURSE, N50

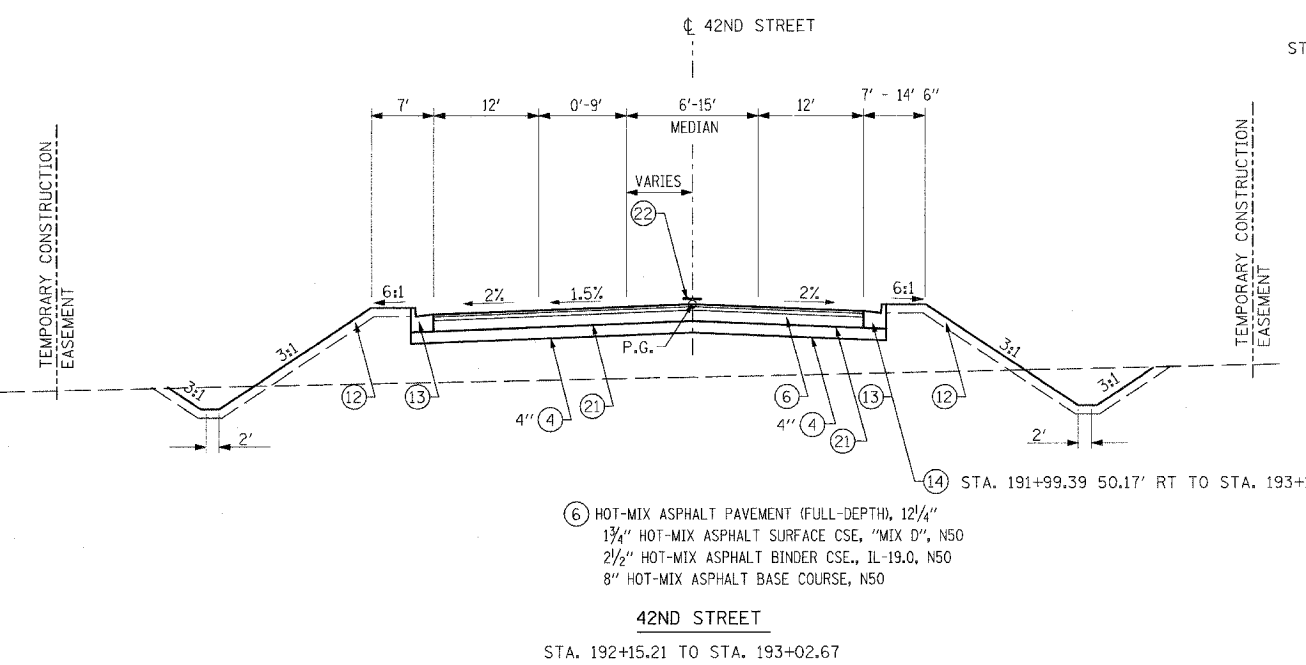

⑥ HOT-MIX ASPHALT PAVEMENT (FULL-DEPTH), 12 1/4"
1 3/4" HOT-MIX ASPHALT SURFACE CSE, "MIX D", N50
2 1/2" HOT-MIX ASPHALT BINDER CSE., IL-19.0, N50
8" HOT-MIX ASPHALT BASE COURSE, N50

Copyright Hanson Professional Services Inc. 2007
HANSON
 Hanson Professional Services Inc.
 03/22/2007, 02:47 PM
 I:\98\98963\Road\Sheet\C_301_42.dwg
 LAYOUT: RLT 02/26/04
 DRAWN: JEO 04/22/04
 REVISION: MTM 03/22/07