

| | | | | |
|---------------------|-----------|------------------|--------------|-----------|
| F.A.I. RTE. | SECTION | COUNTY | TOTAL SHEETS | SHEET NO. |
| 57/64 | (41-3)HBK | JEFFERSON | 518 | 017 |
| STA. | | TO STA. | | |
| FED. ROAD DIST. NO. | ILLINOIS | FED. AID PROJECT | | |
| CONTRACT NO. 98963 | | | | |

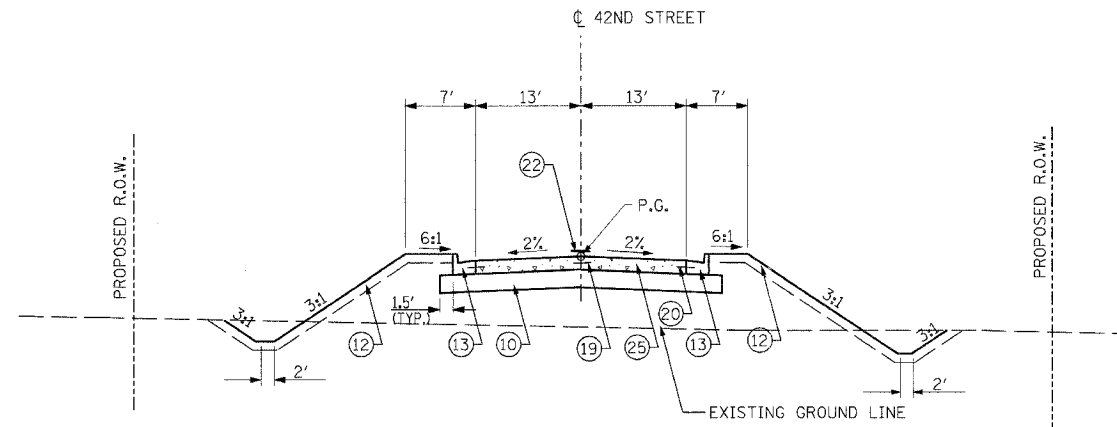

42ND STREET
STA. 206+57.15 TO STA. 207+32.15

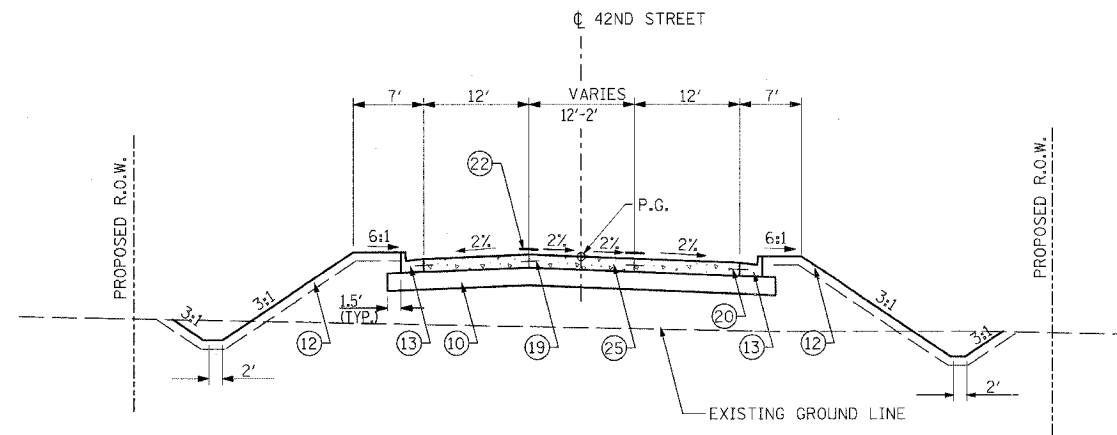

42ND STREET
STA. 204+26.87 TO STA. 206+57.15

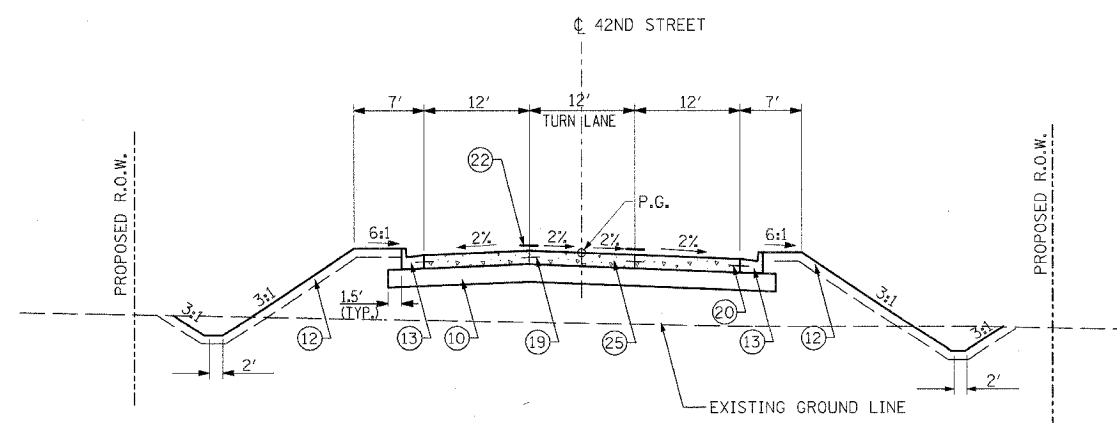

42ND STREET
STA. 197+85.94 TO STA. 204+26.87
INTERSECTION OMISSION STA. 198+22.47 TO STA. 201+70.70
(VETERAN'S MEMORIAL DRIVE)

LEGEND:

- ① PORTLAND CEMENT CONCRETE PAVEMENT, JOINTED 9 1/2"
- ② SUB-BASE GRANULAR MATERIAL, TYPE A 12 1/2"
- ③ AGGREGATE SURFACE COURSE, TYPE A 8"
- ④ AGGREGATE BASE COURSE, TYPE A
- ⑤ AGGREGATE SHOULDERS TYPE B, 6"
- ⑥ HOT MIX ASPHALT PAVEMENT (FULL-DEPTH), 12 1/4"
- ⑦ HOT MIX ASPHALT SURFACE CSE. "MIX D", N50 1 3/4"
- ⑧ HOT MIX ASPHALT BINDER CSE. IL-19.0, N50 2 1/2"
- ⑨ HOT MIX ASPHALT SHOULDERS, 8"
- ⑩ LIME MODIFIED SOIL, 12"
- ⑪ PORTLAND CEMENT CONCRETE SIDEWALK, 4"
- ⑫ TOPSOIL FURNISH AND PLACE, 4"
- ⑬ COMBINATION CONCRETE CURB & GUTTER, TYPE B-6.24
- ⑭ COMBINATION CONCRETE CURB & GUTTER, TYPE B-6.18
- ⑮ COMBINATION CONCRETE CURB & GUTTER, TYPE B-6.12
- ⑯ COMBINATION CONCRETE CURB & GUTTER, TYPE B-6.06
- ⑰ CONCRETE MEDIAN, TYPE SB-6
- ⑱ CONCRETE MEDIAN SURFACE, 4"
- ⑲ NO. 6 EPOXY COATED TIE BARS IN ACCORDANCE WITH STANDARD 420101, SECTION 420 OF THE STANDARD SPECIFICATIONS AND THE FOLLOWING TABLE:

| LONGITUDINAL JOINT TYPE | BAR SIZE | SPACING |
|-------------------------|----------|---------|
| SAWED CONSTRUCTION | NO. 6 | 30" |
| | NO. 6 | 24" |

- ⑳ NO. 6 EPOXY COATED TIE BARS AT 24" CENTERS IN ACCORDANCE WITH STANDARD 606001
- ㉑ BITUMINOUS MATERIALS (PRIME COAT)
- ㉒ PAVEMENT MARKINGS (SEE PAVEMENT MARKING PLANS FOR TYPE AND LOCATIONS)
- ㉓ HOT MIX ASPHALT SURFACE REMOVAL, VARIABLE DEPTH
- ㉔ LEVELING BINDER, (MACHINE METHOD), N50 2 1/4"
- ㉕ PORTLAND CEMENT CONCRETE PAVEMENT JOINTED 8 1/2" (UNREINFORCED)
- ㉖ BITUMINOUS SURFACE TREATMENT, CLASS A-3
- ㉗ PAVEMENT FABRIC

NOTE:
DOWEL AND TIES BARS SHALL NOT BE PAID FOR SEPARATELY BUT SHALL BE INCLUDED IN THE COST OF CONCRETE PAVEMENT AND/OR CONCRETE CURB AND GUTTER.

| REVISIONS | |
|-----------|------|
| NAME | DATE |
| | |
| | |
| | |
| | |
| | |
| | |
| | |
| | |
| | |
| | |

ILLINOIS DEPARTMENT OF TRANSPORTATION
TYPICAL SECTIONS
42ND STREET
VETERANS MEMORIAL DRIVE
INTERCHANGE
SECTION (41-3)HBK
SCALE: NO SCALE
DATE 3-22-07
DRAWN BY RLT
CHECKED BY MTM

© Copyright Hanson Professional Services Inc. 2007
HANSON
Hanson Professional Services Inc.

03/22/2007 02:48 PM
A:\98\Jobs\98s\20190\Froad\Sheet\AC-302-42.dgn

| | | |
|----------|-----|----------|
| LAYOUT | RLT | 02/26/04 |
| DRAWN | JED | 07/22/04 |
| REVIEWED | MTM | 03/22/07 |