

F.A.I. RTE.	SECTION	COUNTY	TOTAL SHEETS	SHEET NO.
57/64	(41-3)HBK	JEFFERSON	518	287
STA.		TO STA.		
FED. ROAD DIST. NO.	ILLINOIS	FED. AID PROJECT		
CONTRACT NO. 98963				

Sheet 14 of 25

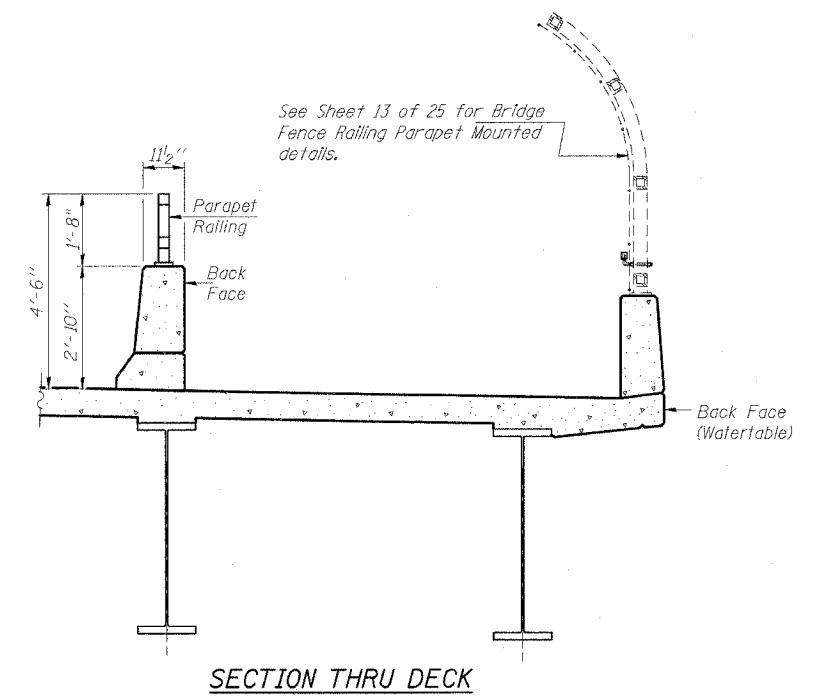

NOTE
All steel rail elements shall be galvanized according to Article 509.05 of the Standard Specifications.

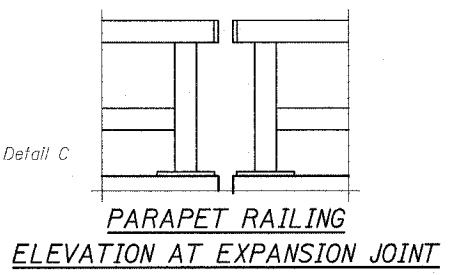
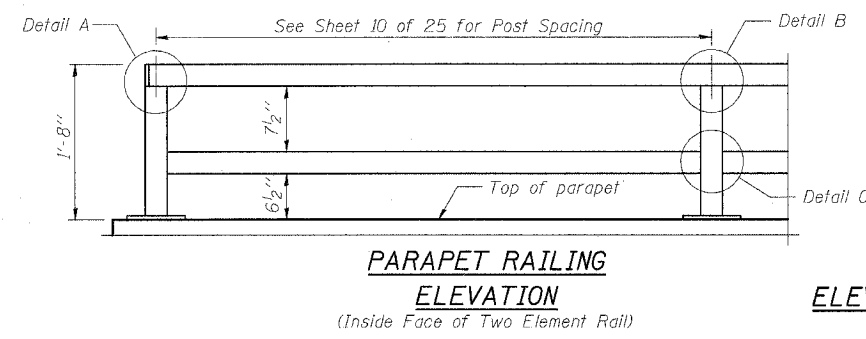
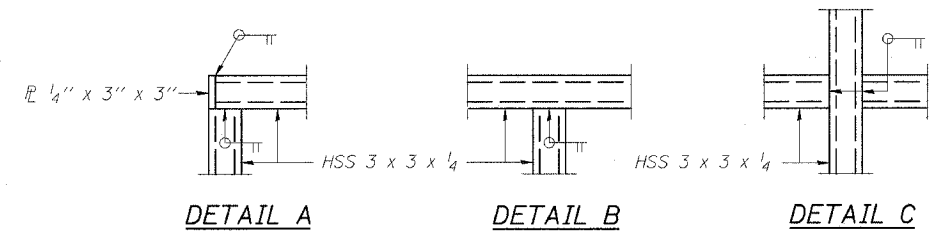
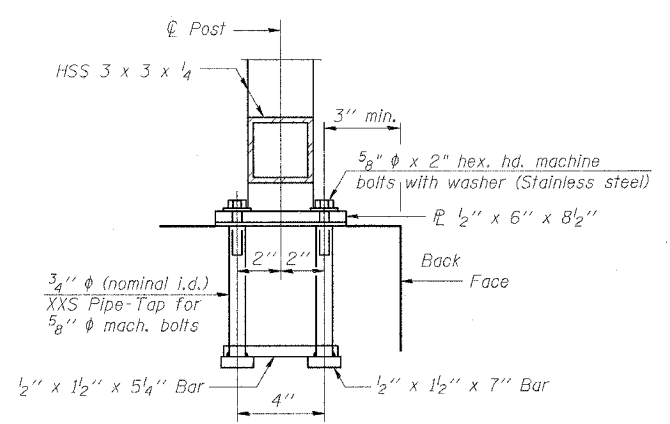
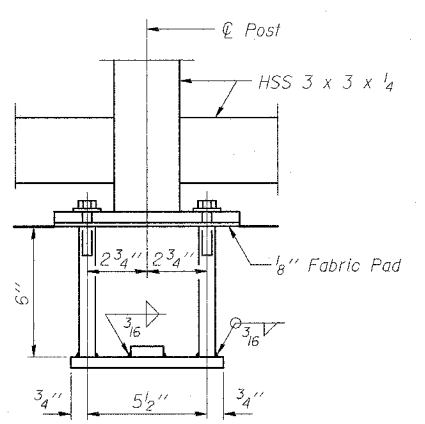
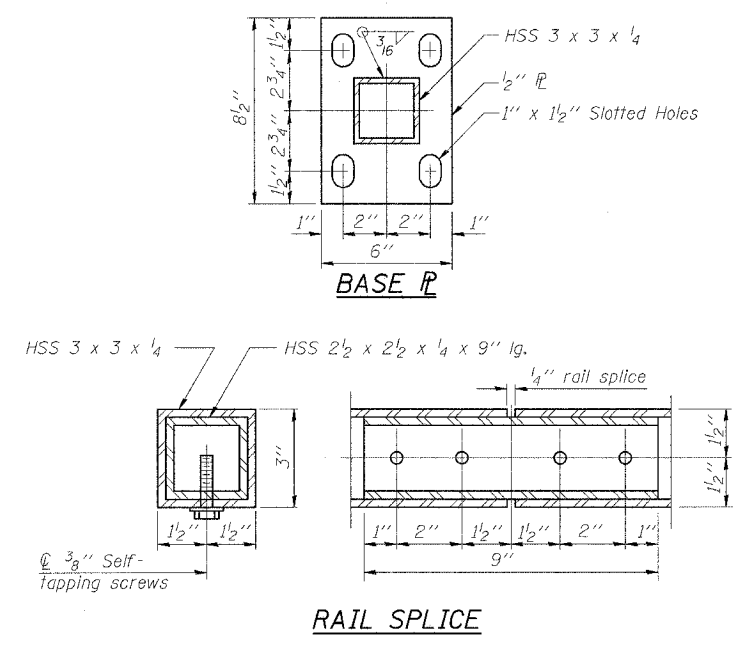

ANCHOR BOLT DETAILS
In lieu of the cast-in-place anchor device shown, the Contractor has the option of drilling and setting 5/8" φ anchor rods according to Article 509.06 of the Standard Specifications. Embedment shall be according to the manufacturer's specifications.

BILL OF MATERIAL

Item	Unit	Quantity
Parapet Railing	Foot	260

BICYCLE RAILING
VETERANS MEMORIAL DR. over F.A.I. ROUTES 57/64
SECTION (41-3)HBK
JEFFERSON COUNTY
STATION 49+72.27
STRUCTURE NO. 041-0108

© Copyright Hanson Professional Services Inc. 2007
JOB NO. 98S2019A
DATE 03-14-07
HANSON

March 2007 Submittal
LAYOUT: MM 03/12/07
DRAWN: DAB 03/12/07
REVIEWED: / / /
GPH: 02/02/04
AW: 02/02/04
TEH: 02/02/04
05/01/2007, 03:45 PM
\$FILE\$