

TYPICAL SECTION - TAXIWAYS D, A AND E

NOTE:
FOR ADDITIONAL LANDSCAPING INFORMATION, SEE LANDSCAPING PLAN.

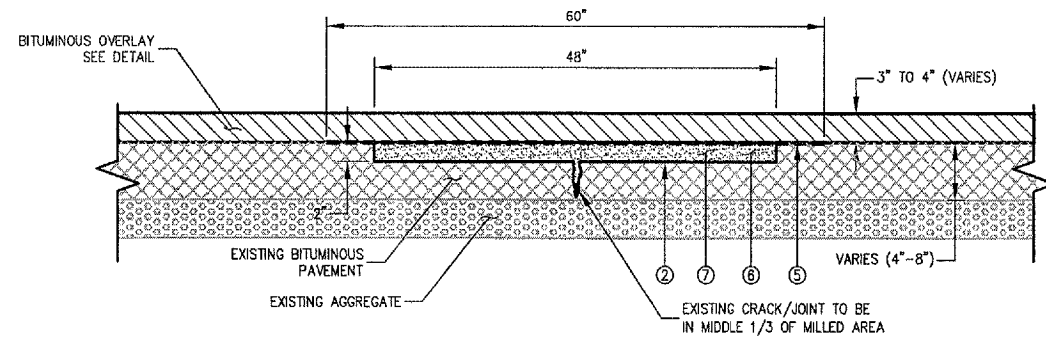

TYPICAL SECTION - PARTIAL DEPTH BITUMINOUS CRACK REPAIR AND PATCH

NOTES:
1. TACK COAT ALL VERTICAL FACES.
2. MILLING AND BITUMINOUS SAND MIX QUANTITIES BASED ON 52" WIDTH.

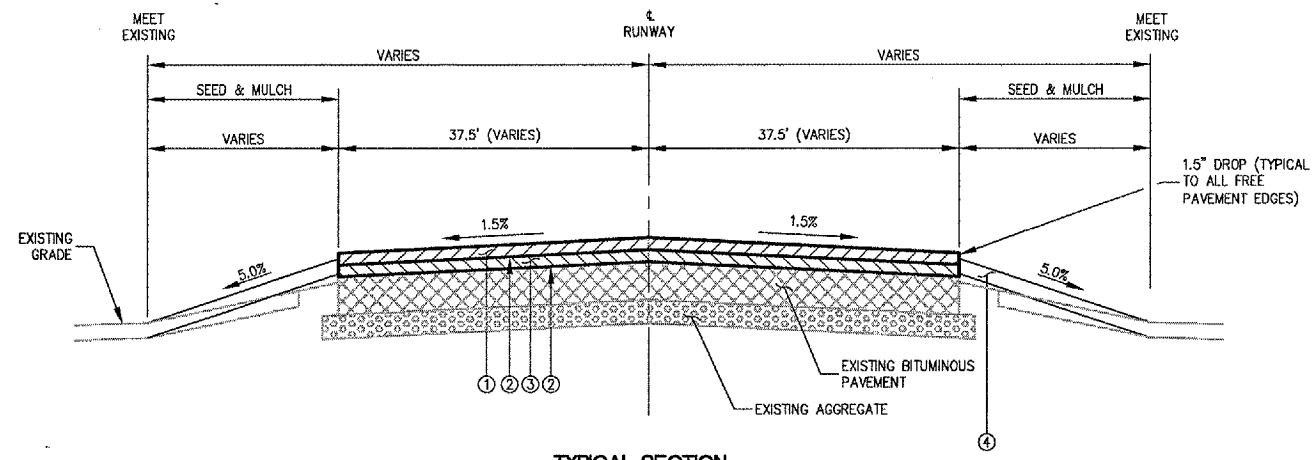

TYPICAL SECTION - RUNWAY 12-30

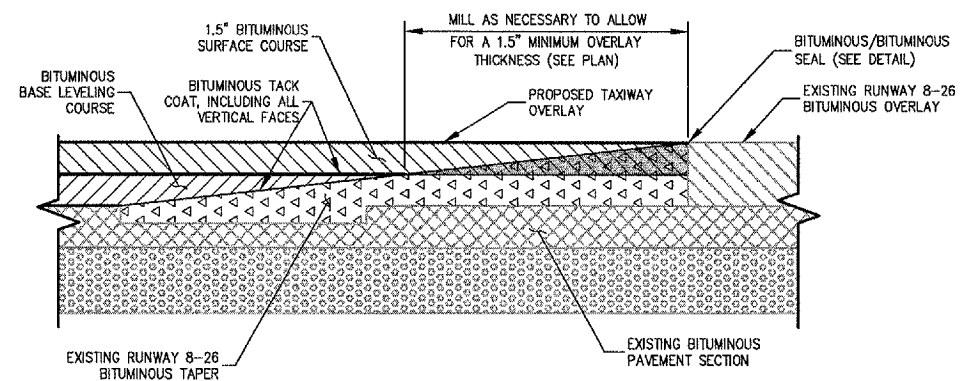

BITUMINOUS MILLING DETAIL

LEGEND

① PROPOSED 1 1/2 INCH BITUMINOUS SURFACE COURSE, ITEM AR401610.	⑦ PAVEMENT MILLING, ITEM AR401650.
② PROPOSED BITUMINOUS TACK COAT, ITEM AR603510.	⑧ PROPOSED BITUMINOUS PRIME COAT, ITEM AR602510.
③ PROPOSED BITUMINOUS BASE LEVELING COURSE (DEPTH VARIES APPROXIMATELY 1.5" TO 2.5"), ITEM AR201620.	⑨ PROPOSED 3 INCH BITUMINOUS SURFACE COURSE, INCLUDED IN ITEM AR401910.
④ PROPOSED 4 INCH TOPSOIL, ITEM AR905520. SEEDING AND MULCHING AREAS, ITEMS AR901510 AND AR808510.	⑩ PROPOSED 3 INCH BITUMINOUS BASE COURSE, INCLUDED IN ITEM AR401910.
⑤ CRACK CONTROL MATERIAL (60" WDE), ITEM AR800973.	⑪ PROPOSED 12 INCH CRUSHED AGGREGATE BASE COURSE, INCLUDED IN ITEM AR401910.
⑥ BITUMINOUS SAND MIX - 2 INCH, ITEM AR800972.	⑫ COMPACTED EXISTING SUBGRADE INCLUDED IN ITEM AR401910. REMOVAL AND REPLACEMENT OF UNSUITABLE SUBGRADE PAID UNDER ITEM AR152410.

No.	Drawing Issue	Description	Date	By

Date: APRIL 20, 2007
Sheet Title:

TYPICAL SECTIONS AND PAVEMENT DETAILS

843-06B8013

Project Number	LDH	09/14/06
Layout By	LDH	09/14/06
Designed By	RMH	04/20/07
Reviewed By	LDH	
Drawn By		

DETAILS SHOWN ARE NOT TO SCALE

A: 06/08/07 [06B8013] DRAWINGS SHEETS 10-TYPICAL SECTIONS.DWG MAY 14, 2007 2:12PM LDH

NOTES:
1. ALL WORK RELATED TO THE PAVEMENT REMOVAL AND REPLACEMENT IS INCLUDED IN ITEM AR401910 EXCEPT FOR PAVEMENT SAWING.
3. WIDTH OF PATCH SHALL BE REDUCED BASED ON REQUIRED WIDTH OF PATCH. WIDTH NOT TO EXCEED THAT SHOWN ON THE DETAIL.

BITUMINOUS PAVEMENT REMOVAL AND REPLACEMENT (ITEM AR401910)

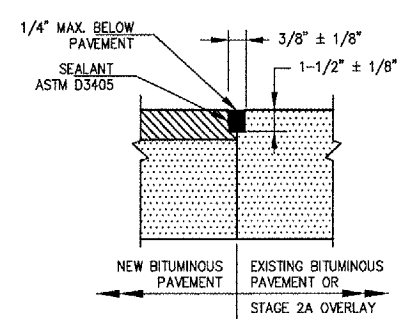

NOTE:
ALL JOINT SEALING TO BE PAID UNDER SAW AND SEAL BITUMINOUS JOINTS, ITEM AR401660.

BITUMINOUS/BITUMINOUS SEAL

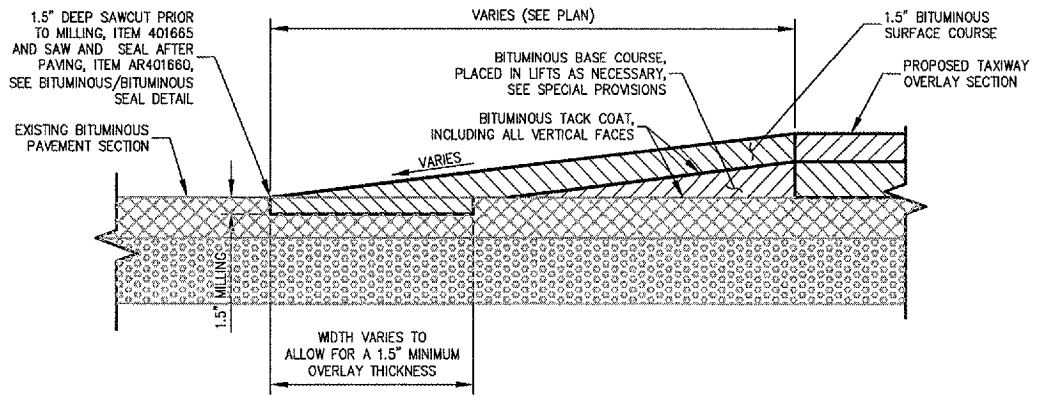

BITUMINOUS TAPER DETAIL