

REMOVAL SECTION - TAXIWAY A6

N.T.S.

EE

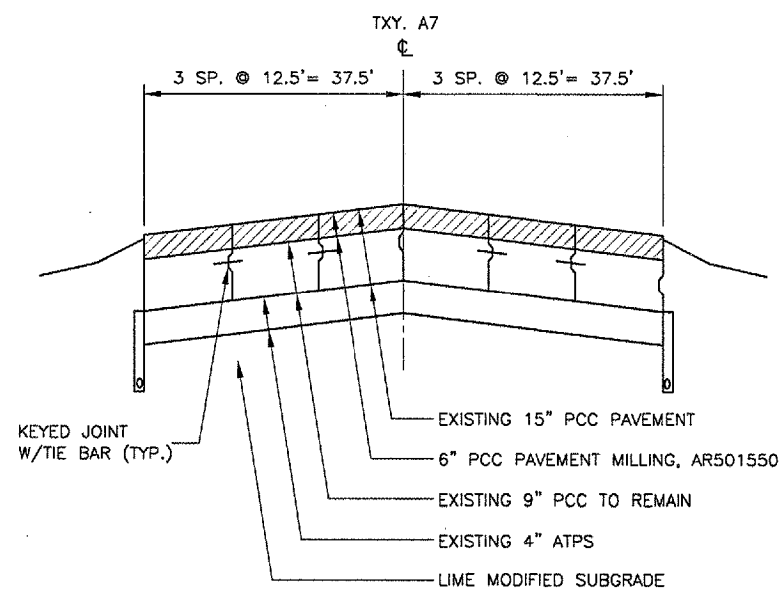

REMOVAL SECTION - TAXIWAY A7

N.T.S.

FF

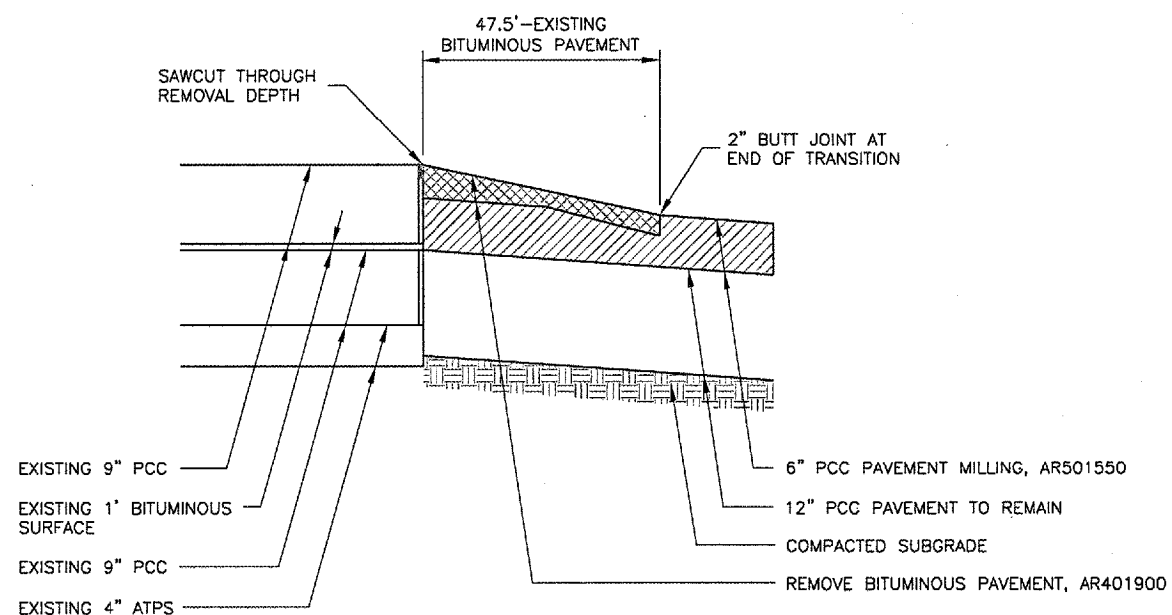

REMOVAL SECTION - TAXIWAY A6 AT APRON

N.T.S.

GG

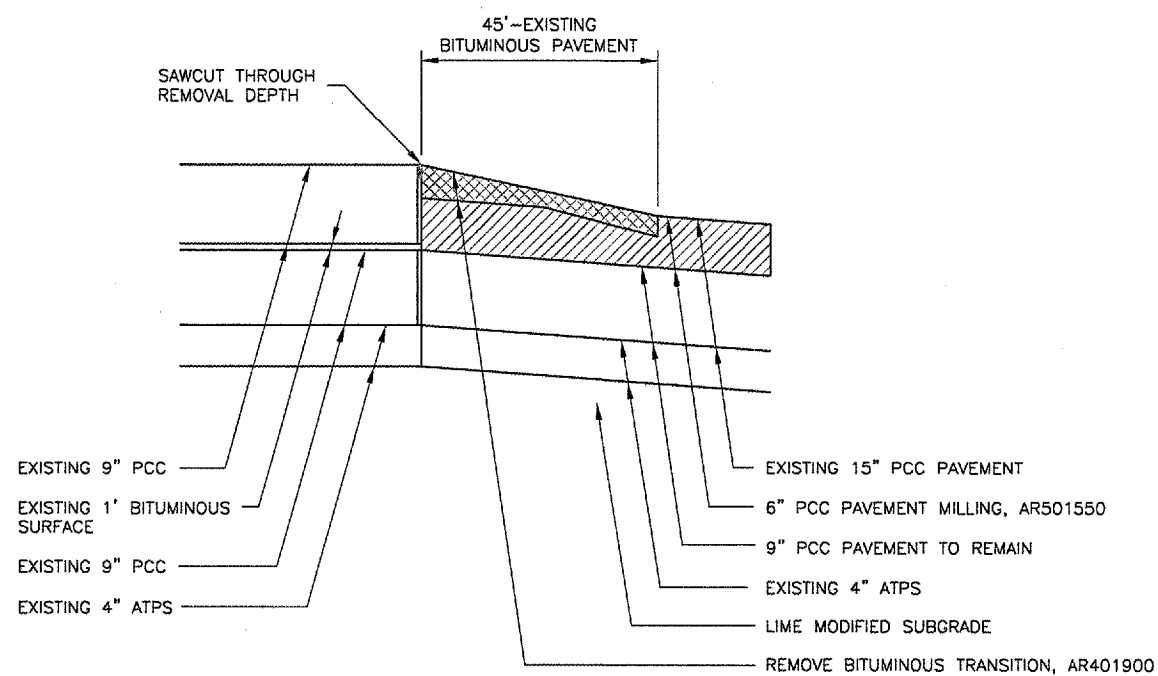

REMOVAL SECTION - TAXIWAY A7 AT APRON

N.T.S.

HH

| REVISIONS |    |      |
|-----------|----|------|
| NUMBER    | BY | DATE |
|           |    |      |
|           |    |      |
|           |    |      |

0 1 2  
 THIS BAR IS EQUAL TO 2"  
 AT FULL SCALE (34x22).

UNIVERSITY OF ILLINOIS  
 WILLARD AIRPORT

REHABILITATE AIR CARRIER RAMP, PHASE 2  
 PAVEMENT REMOVAL DETAILS SHEET 2

© Copyright CMT, Inc.



CRAWFORD, MURPHY & TILLY, INC.  
 CONSULTING ENGINEERS  
 License No. 184-000613

|                          |           |
|--------------------------|-----------|
| DESIGN BY:               | SMS       |
| DRAWN BY:                | CMT       |
| CHECKED BY:              | SMB       |
| APPROVED BY:             | SMB       |
| DATE:                    | 4/27/2007 |
| JOB No:                  | 0305903   |
| CMI-3663<br>3-17-0016-XX |           |
| SHEET 14 OF 49 SHEETS    |           |