

REVISIONS		
NUMBER	BY	DATE

0 1 2  
 THIS BAR IS EQUAL TO 2" AT FULL SCALE (34X22).

UNIVERSITY OF ILLINOIS  
 WILLARD AIRPORT  
 REHABILITATE AIR CARRIER RAMP, PHASE 2  
 ELECTRICAL ADJUSTMENTS & DETAILS  
 SHEET 1

© Copyright CMT, Inc.  
**CMT**  
 CRAWFORD, MURPHY & TILLY, INC.  
 CONSULTING ENGINEERS  
 License No. 184-020613

DESIGN BY:	SMS
DRAWN BY:	CMT
CHECKED BY:	<i>SMS</i>
APPROVED BY:	<i>SMS</i>
DATE:	4/27/2007
JOB No:	0305903
CMI-3663 3-17-0016-XX	
SHEET 40 OF 49 SHEETS	

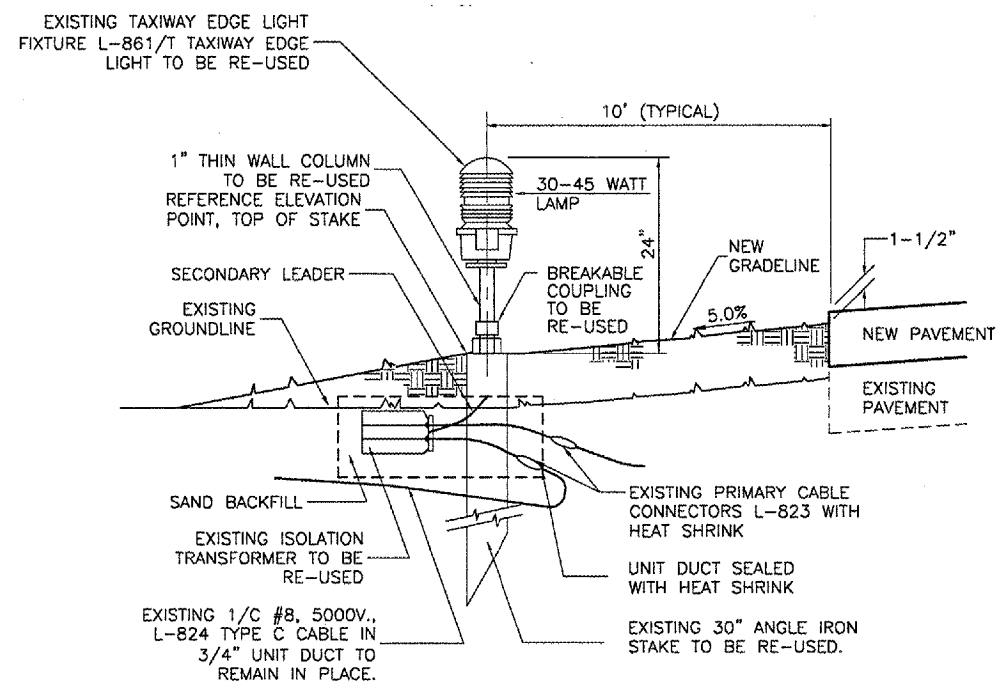

**METHOD OF CONSTRUCTION**

- 1.) ADJUST SHOULDERS TO GRADE.
- 2.) EXCAVATE STAKE MOUNTED LIGHT AND TRANSFORMER AND SET AT NEW ELEVATION.
- 3.) BACKFILL EXCAVATED MATERIAL.

**TAXIWAY STAKE MOUNTED LIGHT ADJUSTMENT**

N.T.S.

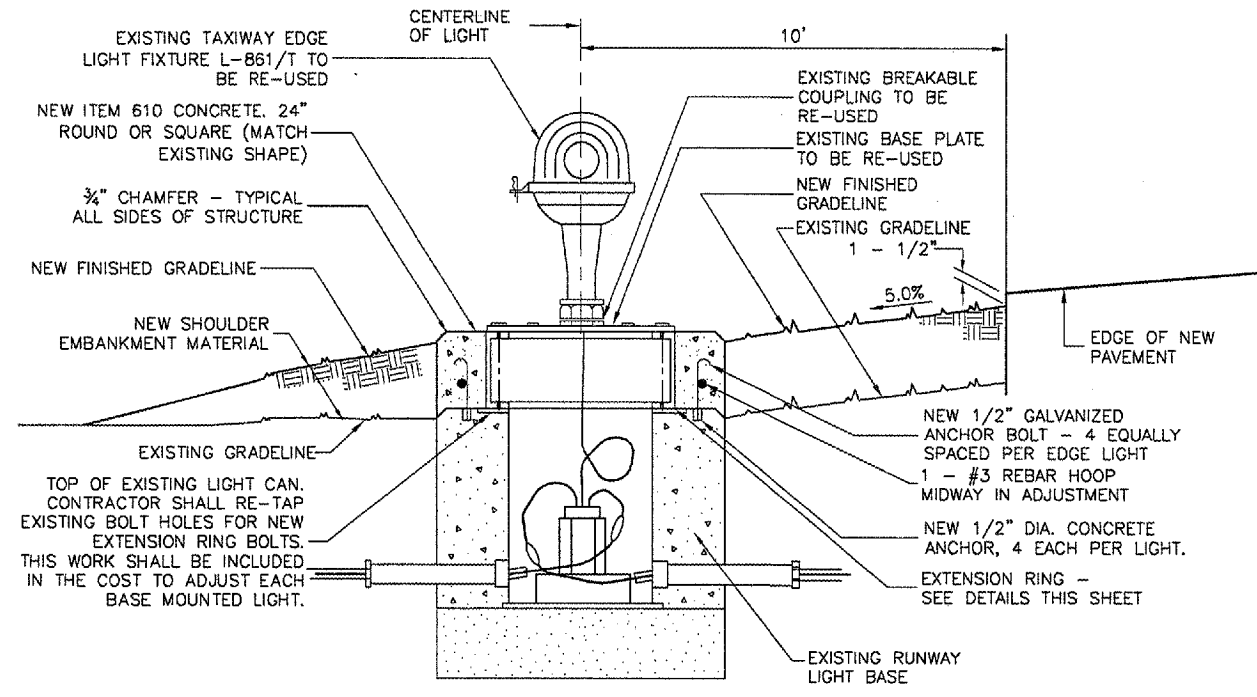

**METHOD OF CONSTRUCTION**

- 1.) ADJUST SHOULDERS TO GRADE.
- 2.) EXCAVATE BASE MOUNTED LIGHT AND INSTALL NEW EXTENSION RING AND CONCRETE TO PROPER GRADE.
- 3.) BACKFILL EXCAVATED MATERIAL.

**TAXIWAY BASE MOUNTED LIGHT ADJUSTMENT**

N.T.S.

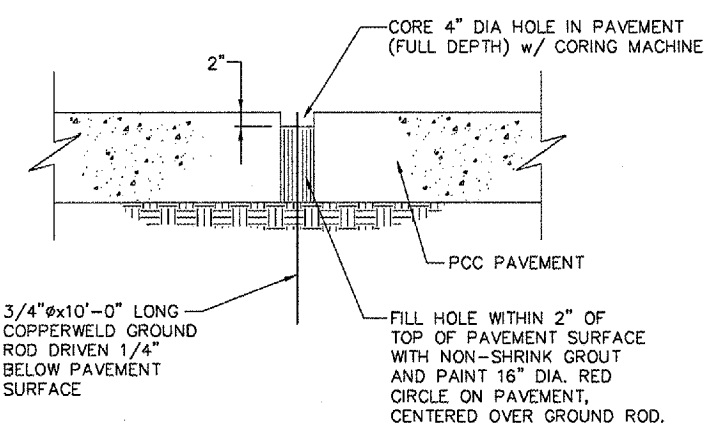

**GROUND ROD DETAIL**

N.T.S.

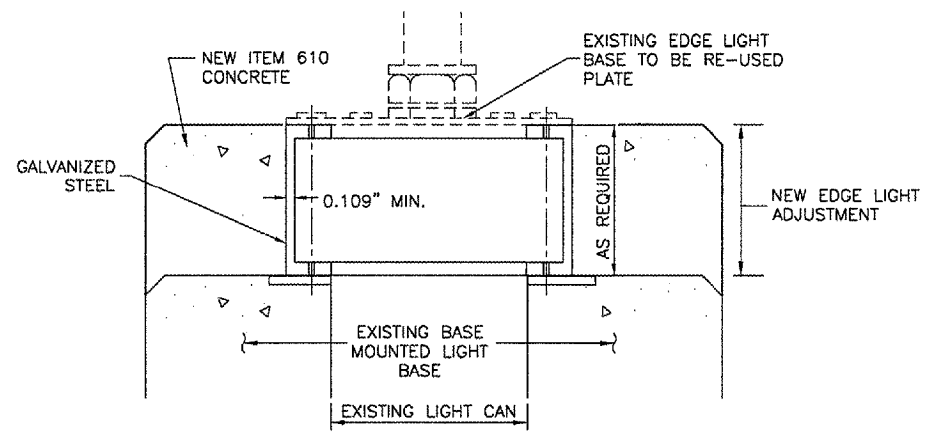

**EXTENSION RING DETAIL**

N.T.S.

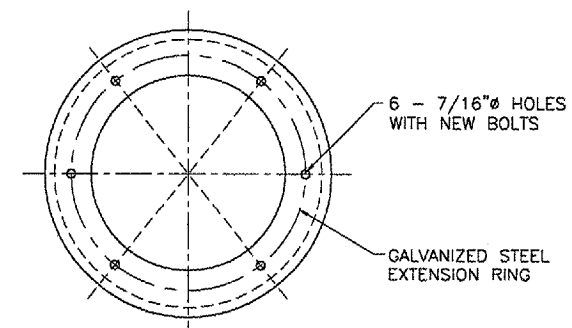

NOTE: 1.) THE CONTRACTOR SHALL FIELD VERIFY EXISTING LIGHT BASE TYPE (MOST ARE L-867, 12" DIA. CLASS 1) AND CALCULATE REQUIRED HEIGHT ADJUSTMENT DIMENSION BASED ON PROPOSED SHOULDER ELEVATION AND THE ELEVATION OF THE TOP OF THE EXISTING LIGHT BASE. NO ADDITIONAL PAYMENT WILL BE MADE FOR ALTERNATE LIGHT CAN TYPES. RETAPPING EXISTING BOLT HOLES IF REQUIRED AND SHALL BE CONSIDERED INCIDENTAL TO THE UNIT PRICE FOR LIGHT ADJUSTMENT.