

NOTES:
 1. All steel rail elements shall be galvanized according to Article 509.05 of the Standard Specifications.

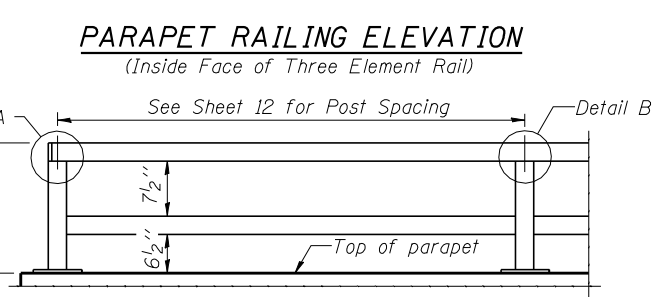
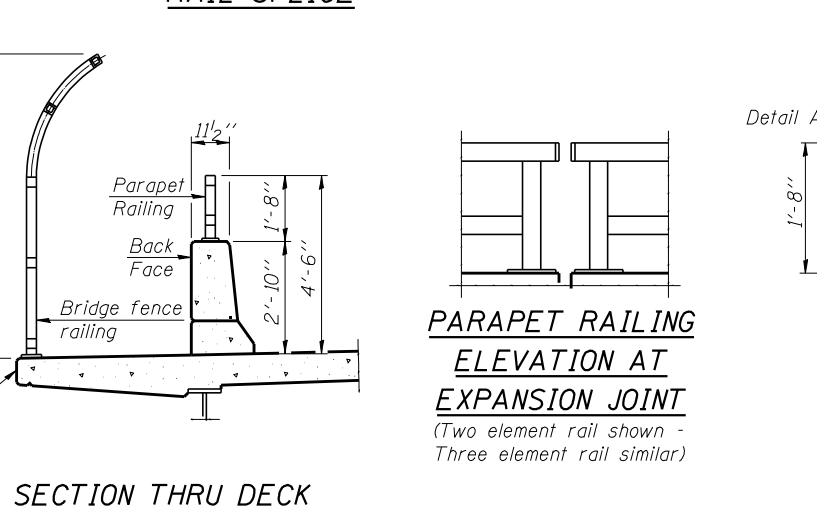
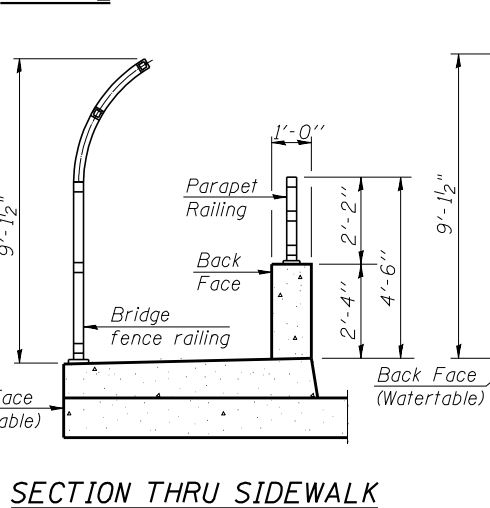
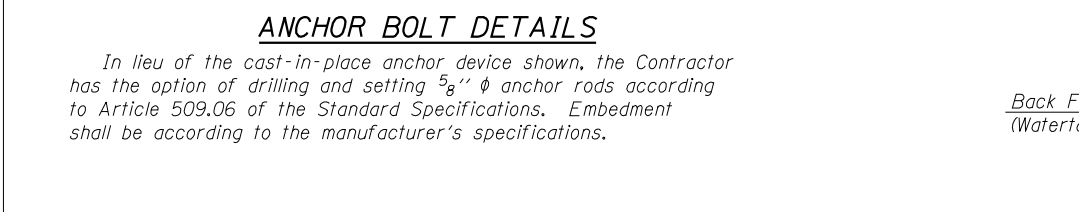
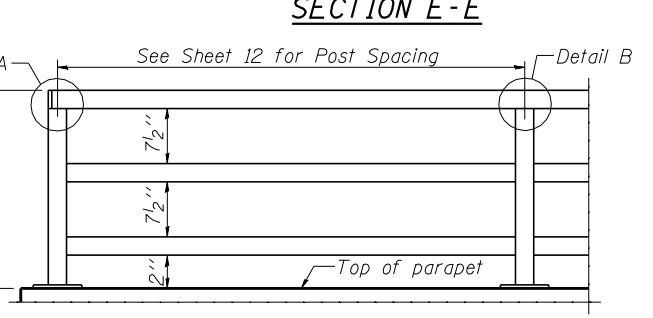
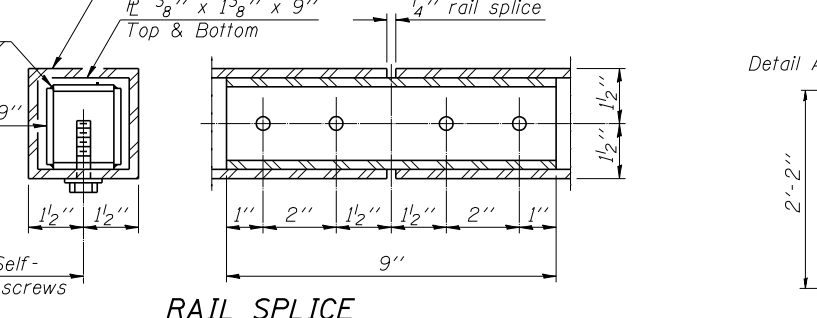
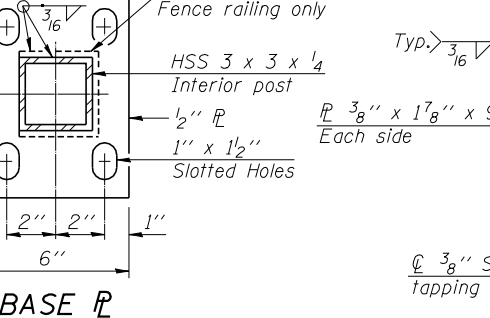
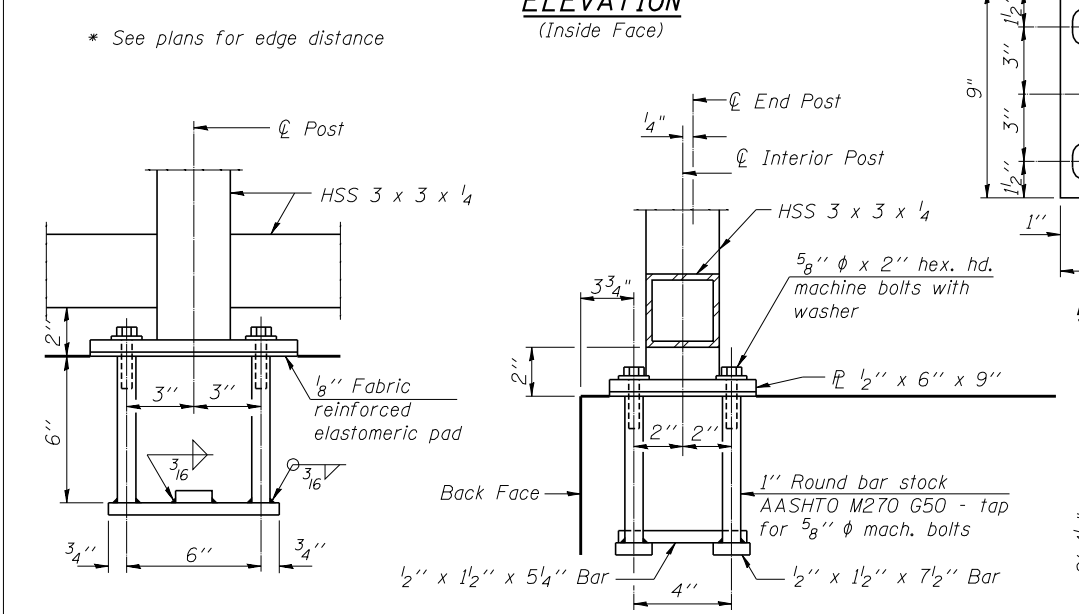

PARAPET RAILING ELEVATION AT EXPANSION JOINT
 (Two element rail shown - Three element rail similar)

BILL OF MATERIAL

Item	Unit	Quantity
Bridge Fence Railing (Sidewalk)	Foot	260
Parapet Railing	Foot	261