

TYPICAL SPLITTER ISLAND OR MEDIAN REFUGE
NTS

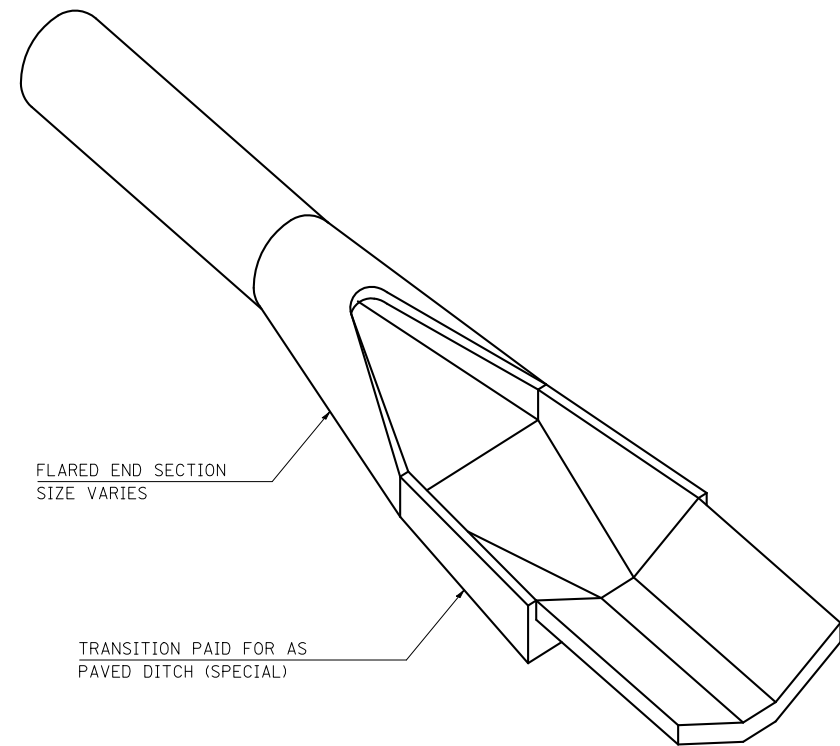

ISOMETRIC VIEW

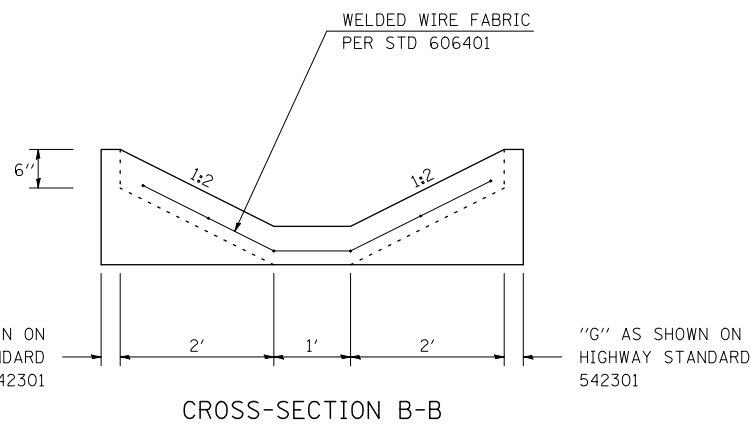

CROSS-SECTION B-B

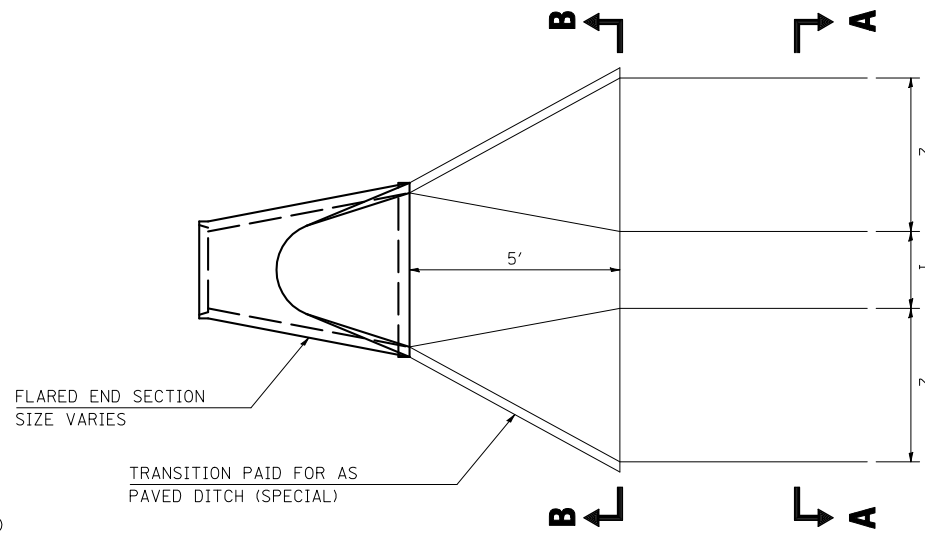

TRANSITION DETAIL
FLARED END SECTION
(SIZE VARIES)

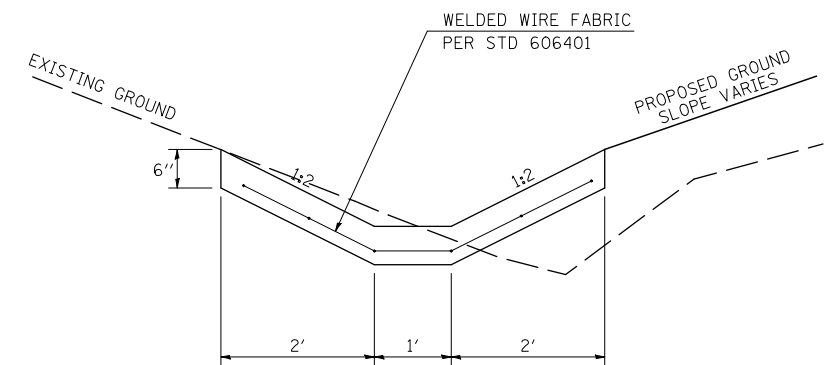

CONCRETE AREA = 0.278 SQ YD

CROSS-SECTION A-A

PAVED DITCH (SPECIAL)

LAST SAVED = 2/20/2012
PEN TABLE = V:\HAF\141
PLOT DRIVER = TR-18pdf-Block-Half.plt

FILE NAME =	USER NAME = beriechmann	DESIGNED -	REVISED -
1:\0906600\0906603\cad\t\plans\100-D876006-Sht-Details.dgn		DRAWN -	REVISED -
	PLOT SCALE = 40.0000 ' / IN.	CHECKED -	REVISED -
	PLOT DATE = 3/20/2012 4:13:05 PM	DATE -	REVISED -

STATE OF ILLINOIS
DEPARTMENT OF TRANSPORTATION

HORNER &
SHIRIN, INC
ENGINEERS

DETAILS

SCALE: NONE SHEET NO. 2 OF 3 SHEETS STA. TO STA.

① F.A.P. RTE 809 / F.A.U. RTE 9251 / F.A.U. RTE 9269

F.A. RTE.	SECTION	COUNTY	TOTAL SHEETS	SHEET NO.
①	135-N	ST. CLAIR	206	165
			CONTRACT NO. 76D06	
ILLINOIS FED. AID PROJECT				