

DATE	
BY	
REVISIONS	
NO.	
DESCRIPTION	
DATE	
BY	
REVISIONS	
NO.	
DESCRIPTION	
DATE	
BY	
REVISIONS	
NO.	
DESCRIPTION	

DATE	
BY	
REVISIONS	
NO.	
DESCRIPTION	
DATE	
BY	
REVISIONS	
NO.	
DESCRIPTION	
DATE	
BY	
REVISIONS	
NO.	
DESCRIPTION	

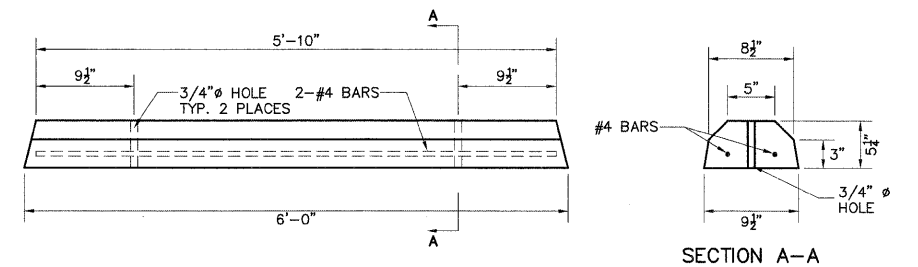

CONCRETE PARKING BLOCK DETAIL
NOT TO SCALE

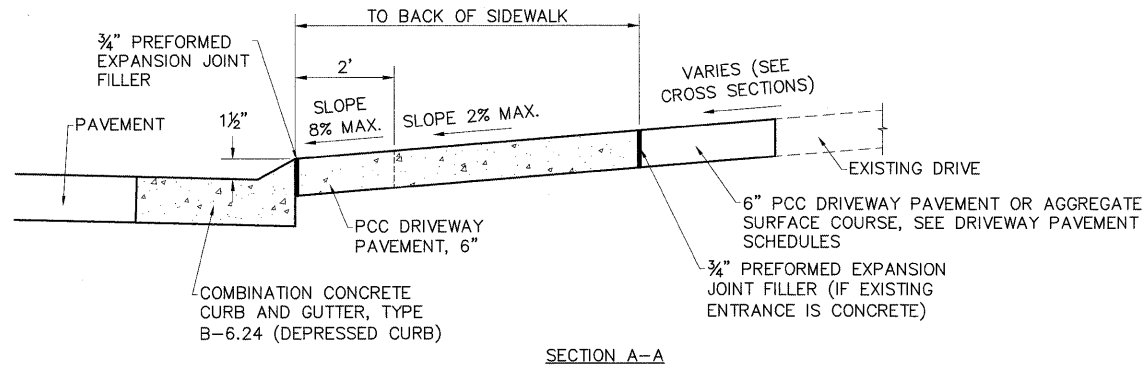
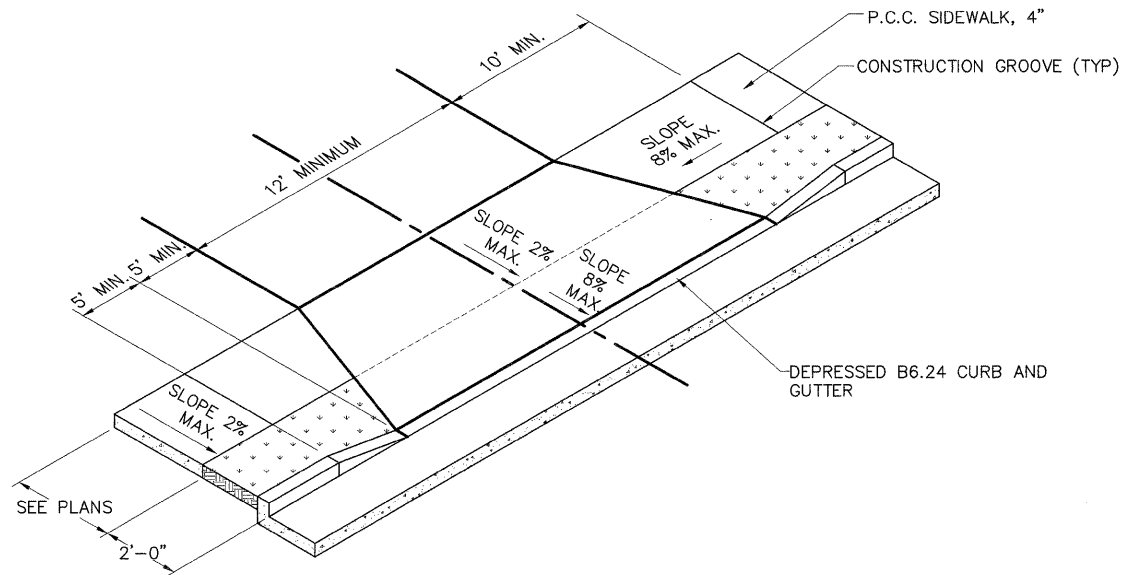
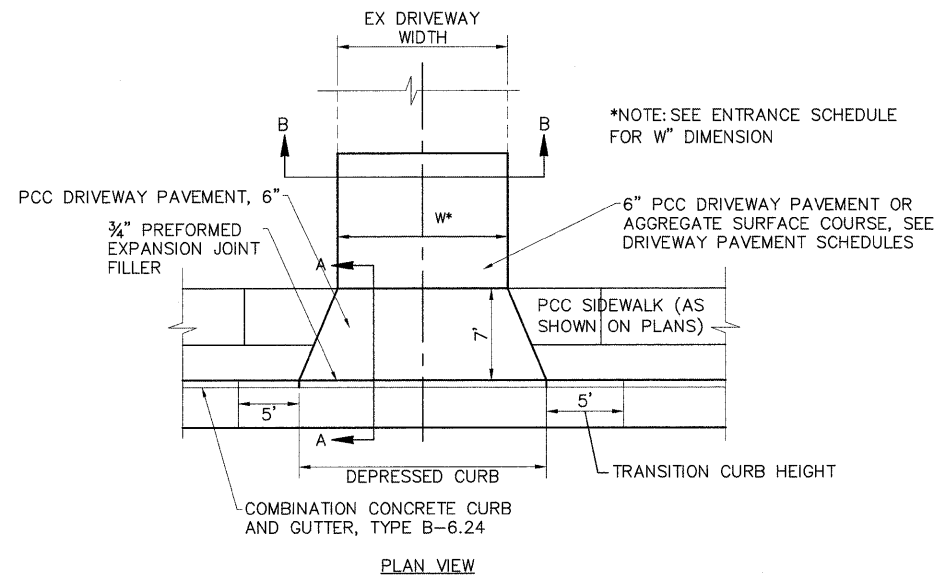
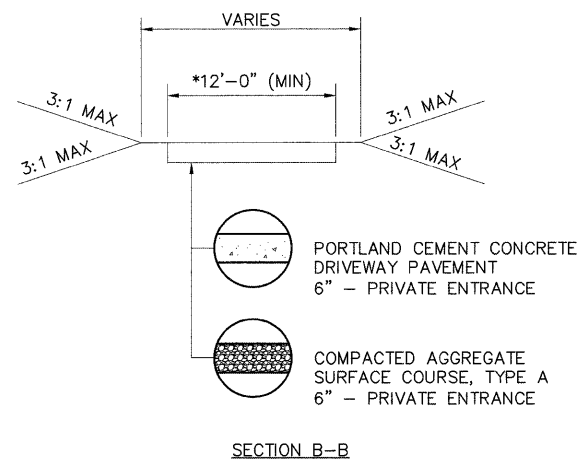

DETAIL OF PRIVATE ENTRANCES
NOT TO SCALE

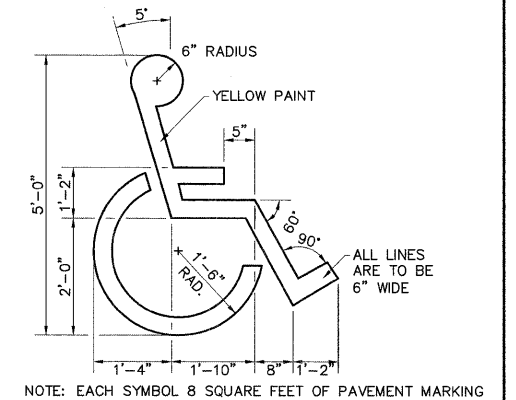
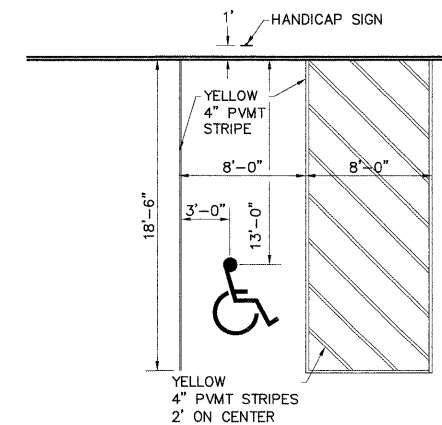

NOTE:
MAXIMUM SLOPE ACROSS
HANDICAPPED SPACE IN ANY
DIRECTION SHALL BE 2%

HANDICAP PARKING SPACE STRIPING DETAIL
NOT TO SCALE

08026-Sht-Details.dwg

USER NAME = Robert Watson	DESIGNED - M.J.R.	REVISED -
PLOT SCALE =	DRAWN - R.A.W.	REVISED -
PLOT DATE = 4/6/2012	CHECKED - E.R.O.	REVISED -
	DATE - 3/21/12	REVISED -

STATE OF ILLINOIS
DEPARTMENT OF TRANSPORTATION

MISCELLANEOUS DETAILS

SCALE: SHEET NO. 48 OF 62 SHEETS STA. TO STA.

F.A.U. RTE.	SECTION	COUNTY	TOTAL SHEETS	SHEET NO.
8959	08-00026-00-WR	MADISON	62	49
CONTRACT NO. 97493				
BETHALTO ILLINOIS FED. AID PROJECT				