

STATE OF ILLINOIS  
DEPARTMENT OF TRANSPORTATION

ROUTE NO.	SECTION	COUNTY	TOTAL SHEETS	SHEET NO.
		COOK	9	5
SHEETS				

Contract Number **6021**  
**NOTES**

Railing shall be according to Section 509 of the Standard Specifications, except as noted, and will be paid for at the Contract Unit Price per foot for Bicycle Railing.  
The 9 gauge fabric ties shall be according to Article 1006.27 (d) of the Standard Specifications.  
Installation of the chain link fabric shall be according to Section 664 of the Standard Specifications.  
Hollow structural sections shall conform to the requirements of ASTM designation A 500, Grade B, structural steel tubing.  
All other steel shapes and plates shall conform to the requirements of AASHTO M 270 Grade 36.  
The Parapet Railing, furnished and installed shall not be paid for separately but shall be included in the unit bid price for Bicycle Railing.  
The chain link fabric shall be placed along Bicycle Side as shown on Section A-A.  
Stretcher bars shall be used at all four sides of each panel.  
If the option of drilling and epoxy grouting the anchor rods is chosen, the Contractor shall use the capsule or the adhesive cartridge type anchor rods that have been previously tested and given a prior approval by the Department. The Contractor shall install these anchor rods in pre-drilled holes according to the manufacturer's recommendations and procedures. The capsule or the adhesive cartridge shall be sealed with pre-measured amounts of the adhesive chemical.  
Space reinforcement to miss anchor rods.

All posts, railing, splices, anchor devices, and bent plates shall be galvanized after shop fabrication according to AASHTO M 111 and ASTM A 385. All bolts, nuts, washers, and anchor rods shall be galvanized according to AASHTO M 232 except stainless steel bolts as noted.  
Vent holes for galvanizing shall be placed in the posts and rails at locations that will not allow the accumulation of moisture in the members.  
The chain link fabric shall conform to the requirements of Article 1006.27(a)(1), b or c of the Standard Specifications.

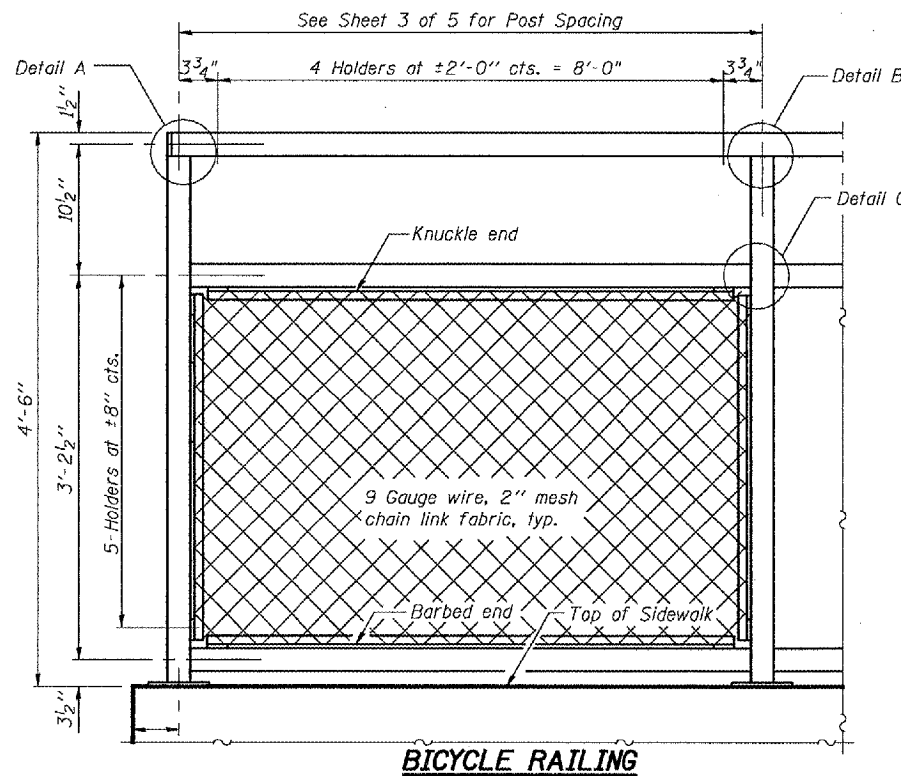

**BICYCLE RAILING**

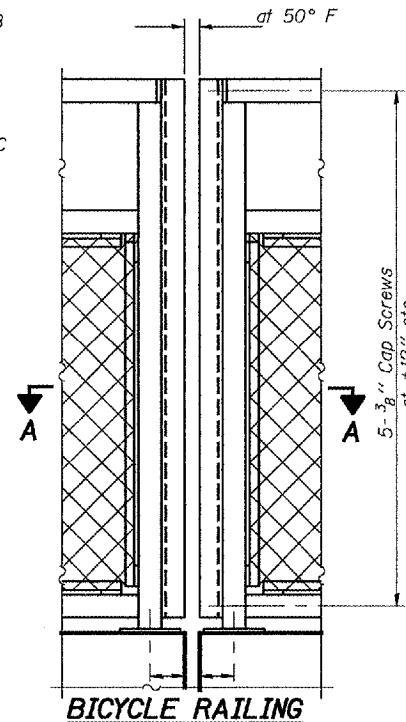

**BICYCLE RAILING**

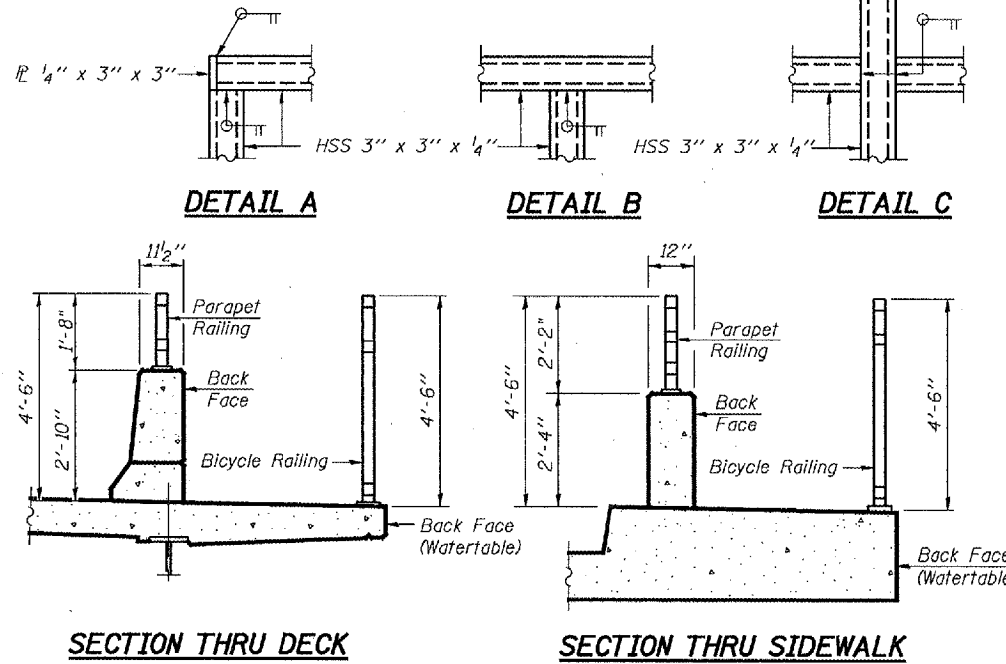

**SECTION THRU DECK**

**SECTION THRU SIDEWALK**

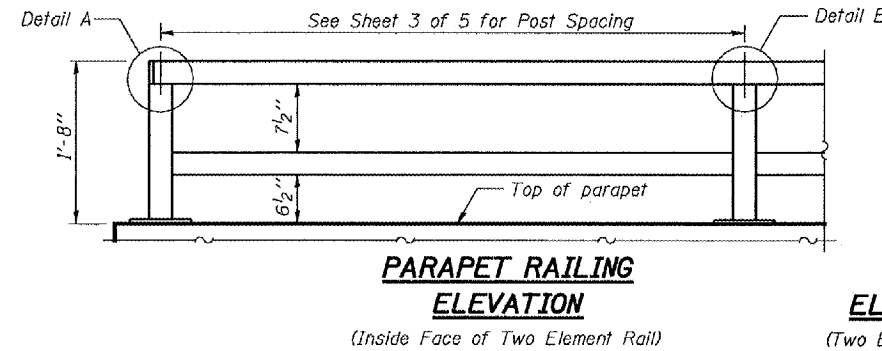

**PARAPET RAILING ELEVATION**

(Inside Face of Two Element Rail)

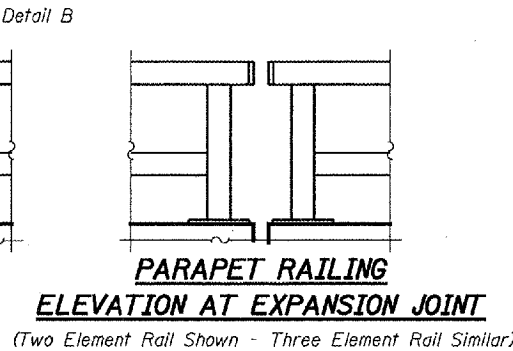

**PARAPET RAILING ELEVATION AT EXPANSION JOINT**

(Two Element Rail Shown - Three Element Rail Similar)

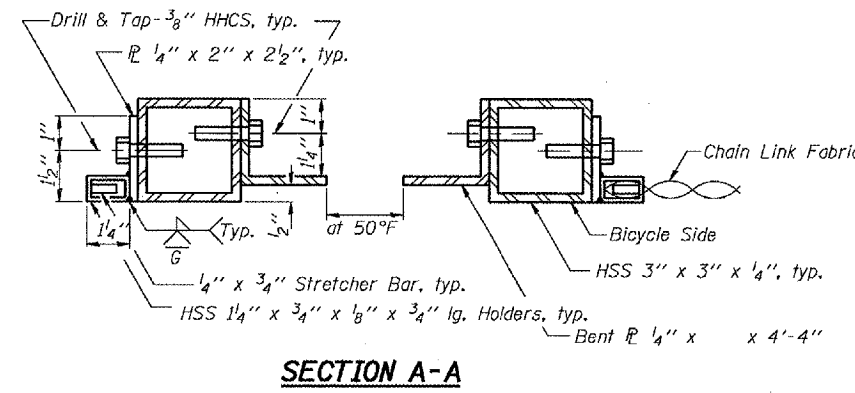

**SECTION A-A**

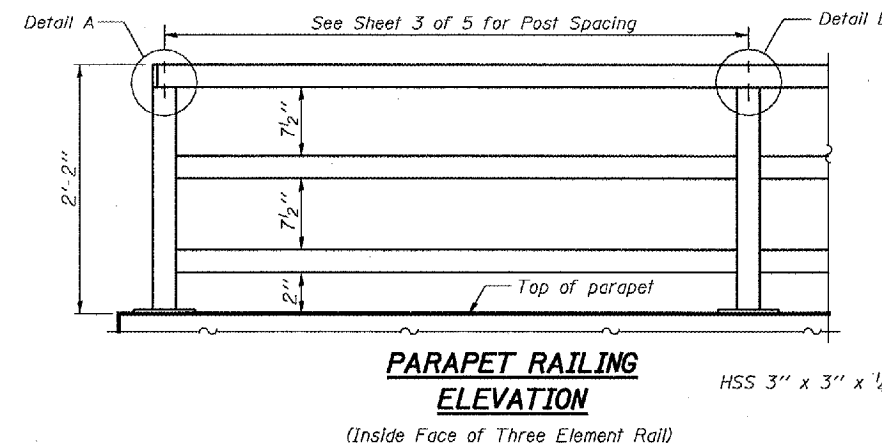

**PARAPET RAILING ELEVATION**

(Inside Face of Three Element Rail)

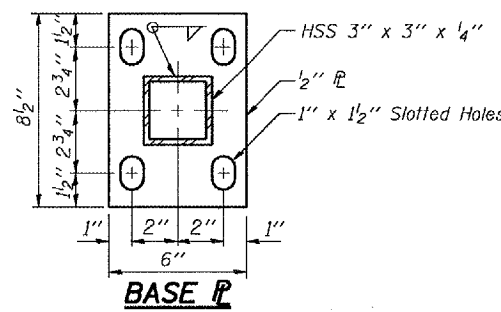

**BASE P**

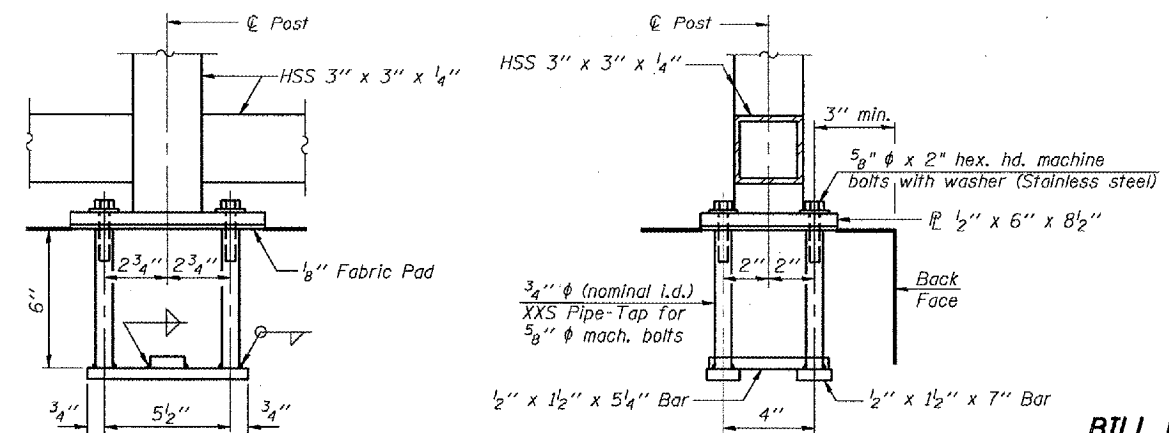

**ANCHOR BOLT DETAILS**

In lieu of the cast-in-place anchor device shown, the Contractor has the option of drilling and epoxy grouting 5/8" φ anchor rods. Embedment shall be according to the manufacturer's specifications.

**BILL OF MATERIAL**

Item	Unit	Quantity
Bicycle Railing	Foot	70

**BICYCLE RAILING DETAILS**  
F.A.P. RT. 559/339  
COOK COUNTY  
SN 016-0349

DESIGNED	V.H.V.
CHECKED	A.T.H.
DRAWN	Drew Christopher
CHECKED	V.H.V.

April 24, 2006  
EXAMINED John A. Morris  
ENGINEER OF STRUCTURAL SERVICES  
PASSED Ralph E. Anderson  
ENGINEER OF BRIDGES AND STRUCTURES

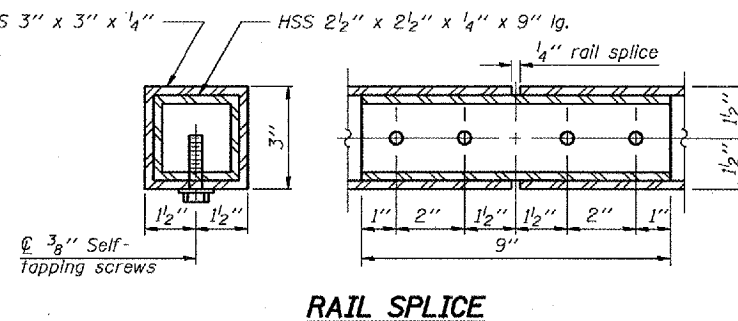

**RAIL SPLICE**

R-29

10-22-04 (10'-0" Maximum Post Spacing)