

STATE OF ILLINOIS  
DEPARTMENT OF TRANSPORTATION

ROUTE NO.	SECTION	COUNTY	TOTAL SHEETS	SHEET NO.
F.A.P. 351	3277R	COOK	66	26
FED. ROAD DIST. NO. 7		ILLINOIS	FED. AID PROJECT-	
Contract No. 62206				

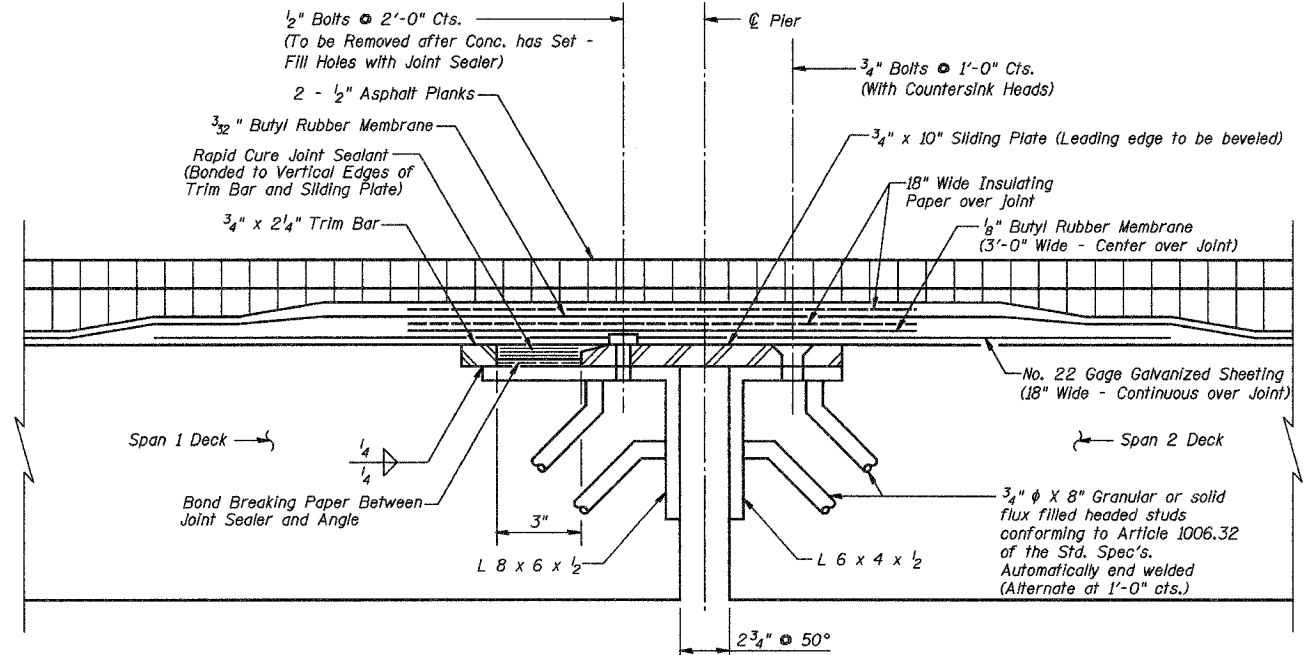

**JOINT DETAIL**  
(At Pier)

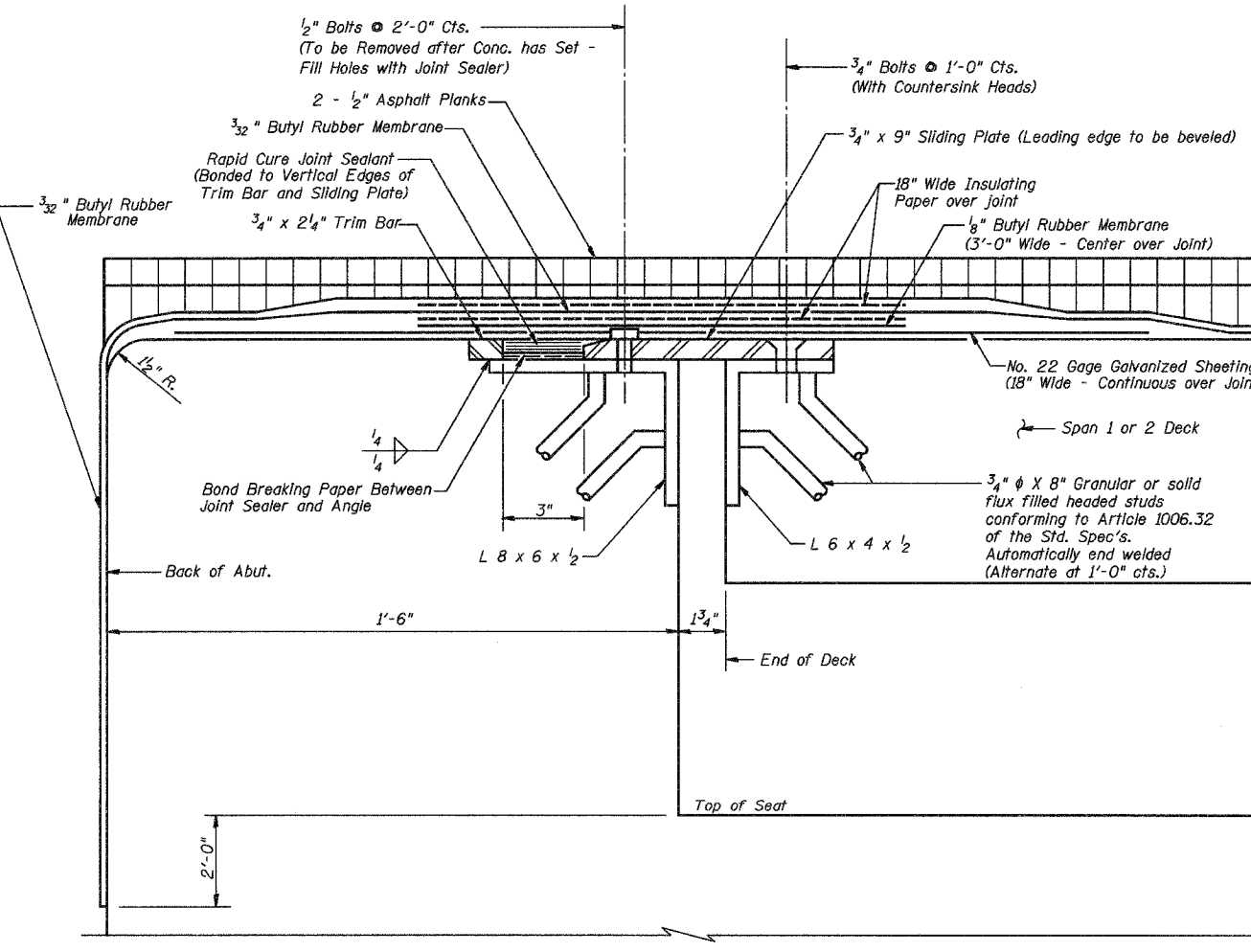

**JOINT DETAIL**  
(At Abutments)

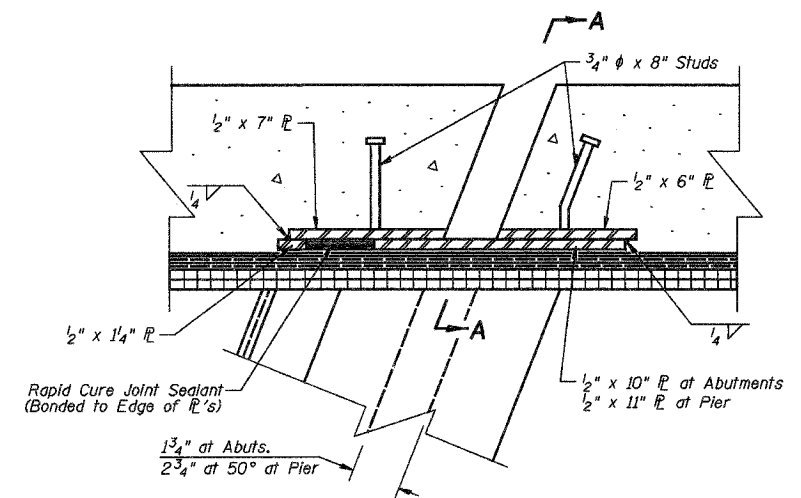

**CURB JOINT DETAIL**

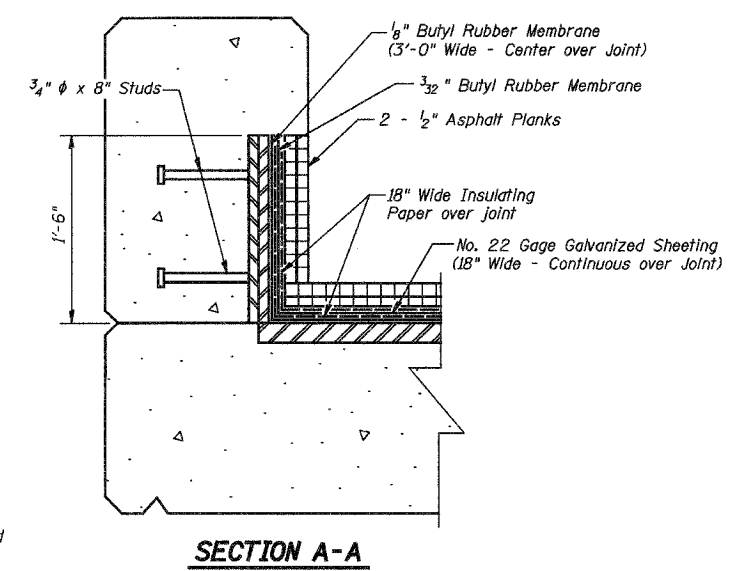

**SECTION A-A**

- Notes:**
- The Waterproofing material at the joints at the Abutments and Pier shall be applied in the following order:
    - Bond-Breaker Paper
    - Rapid Cure Joint Sealant
    - Galvanized Sheet
    - 1/8" Thick Butyl Rubber Membrane
    - Insulating Paper
    - The 3/32" Thick Butyl Rubber Membrane
    - Insulating Paper
    - Asphalt Plank
    - Map Coat of Hot Asphalt

Material shall be included in cost of Membrane Waterproofing (Special)

2. Plates, angles & studs included in cost of Furnishing & Erecting Structural Steel.

3. Steel Angles, Trim Bar, Studs and Sliding Plates shall be Hot Dip Galvanized after Fabrication per ASTM A123 (AASHTO M111). Countersunk Head Bolts shall be Galvanized per ASTM A153 (AASHTO M232).

JOINT DETAILS			
Date 3/27/06	Designed TDN	CN RAILROAD BRIDGE OVER U.S. 6 (159TH STREET) F.A.P. RTE. 351 SECTION 3277R COOK COUNTY STATION 92+24.25 STRUCTURE NO. 016-2754	Sheet No.
Revisions	Drawn SRS		8
	Checked DCS		of 30
	Approved KWB		URS Job No. 36430825
Prepared By:		3040 N. University Ave., Suite 1 Decatur, IL.	