

BAR SPLICER ASSEMBLY DETAIL

Bar Size	No. Assemblies Required	Location
#5	198	Deck
#5	52	North Abutment
#5	18	Pier
#5	28	Sidewalk Retaining Wall
#7	34	North Abutment
#7	4	Sidewalk Retaining Wall
#10	24	Pier

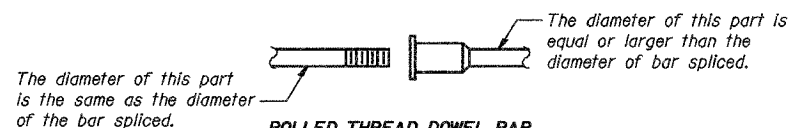

ROLLED THREAD DOWEL BAR



**** ONE PIECE**

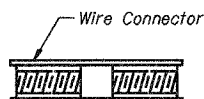

WELDED SECTIONS

BAR SPLICER ASSEMBLY ALTERNATIVES

** Heavy Hex Nuts conforming to ASTM A 563, Grade C, D or DH may be used.

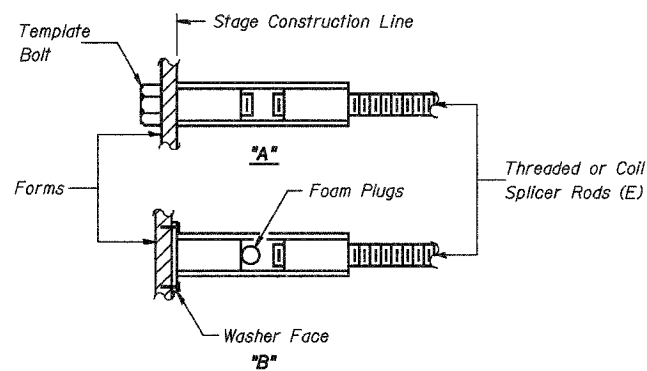

INSTALLATION AND SETTING METHODS

"A": Set bar splicer assembly by means of a template bolt.

"B": Set bar splicer assembly by nailing to wood forms or cementing to steel forms.

(E) : Indicates epoxy coating.

NOTES

Bar splicer assemblies shall be of an approved type and shall develop in tension at least 125 percent of the yield strength of the lapped reinforcement bars.

Splicer rods shall be of minimum 60 ksi yield strength, threaded or coiled full length.

All reinforcement bars shall be lapped and tied to the splicer rods or dowel bars.

Bar splicer assemblies shall be epoxy coated according to the requirements for reinforcement bars.

Other systems of similar design may be submitted to the Engineer for approval. Approval shall be based on certified test results from an approved testing laboratory that the proposed bar splicer assembly satisfies the following requirements:

- ① Minimum Capacity (Tension in kips) = $1.25 \times f_y \times A_f$
- ② Minimum *Pull-out Strength (Tension in kips) = $1.25 \times f_{s_{allow}} \times A_f$

Where f_y = Yield strength of lapped reinforcement bars in ksi.

$f_{s_{allow}}$ = Allowable tensile stress in lapped reinforcement bars in ksi (Service Load)

A_f = Tensile stress area of lapped reinforcement bars.

* = 28 day concrete

Bar Size to be Spliced	Splicer Rod or Dowel Bar Length	Strength Requirements	
		Min. Capacity kips - tension	Min. Pull-Out Strength kips - tension
#5	2'-0"	23.0	9.2
#7	3'-5"	45.1	18.0
#10	7'-3"	95.0	38.0

Bar splicer assemblies shall be according to Section 508 of the Standard Specifications, except as noted. The furnishing and installation of bar splicer assemblies will be measured and paid for at the contract unit price each for BAR SPLICERS.

BAR SPLICER ASSEMBLY DETAILS

Date 3/27/06	Designed DCS	CN RAILROAD BRIDGE OVER U.S. 6 (159TH STREET) F.A.P. RTE. 351 SECTION 3277R COOK COUNTY STATION 92+24.25 STRUCTURE NO. 016-2754	Sheet No.
Revisions	Drawn BKN		27
	Checked TDN		
	Approved KWB		
Prepared By:	3040 N. University Ave., Suite 1 Deerfield, IL.		
			URS Job No. 36430825