

NOTES:

THE PROPOSED WINGWALL CAP SHALL BE POURED THE ENTIRE LENGTH OF THE WINGWALL AND SHALL INCORPORATE THE EXISTING SPBGR HARDWARE PRESENT.

THE CURVED END SECTIONS OF EXISTING RAIL SHALL BE SALVAGED AND REMAIN IN IDOT POSSESSION. AFTER REMOVAL, THE CONTRACTOR SHALL CONTACT DAVE COPENBARGER AT (217) 785-5306 FOR RETRIEVAL OF THE END SECTIONS. ALL OTHER SECTIONS OF RAIL SHALL BE DISPOSED OF BY THE CONTRACTOR. THE CONTRACTOR SHALL INCLUDE THE COST OF THE RAIL REMOVAL AND DISPOSAL IN THE BID PRICE FOR CONCRETE REMOVAL.

ALL CONSTRUCTION JOINTS SHALL BE BONDED.

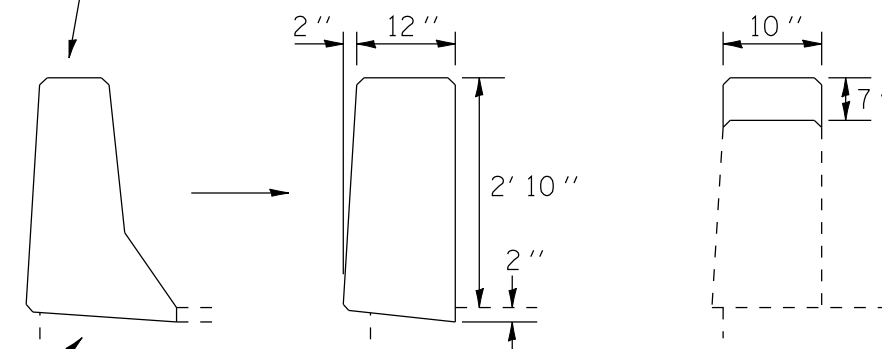

NORMAL CROSS SECTION  
SEE SHEET 5 FOR DIMENSIONS

CROSS SECTION  
TRANSITION DETAIL

CONTRACT 72A37  
APPROACH SLAB  
CONCRETE DETAILS  
(NOT TO SCALE)