

PARTIAL DEPTH PATCHING

STATION	STATION	LANE	LENGTH (FT)	WIDTH (FT)	PARTIAL DEPTH	BITUMINOUS	AGGREGATE	PARTIAL DEPTH	CRACK	MIXTURE FOR
					REMOVAL	PRIME COAT	PRIME COAT	PATCHING	FILLING	CRKS, JNTS. & FGWYS
					SQ. YD.	TON	TON	TON	POUND	TON
I-64 EB										
955+00	955+40	DL	40	2	8.9	0.003	0.013	1.0	15	0.062
956+40	956+90	DL	50	2	11.1	0.003	0.017	1.2	19	0.078
995+00	997+00	DL	200	2	44.4	0.014	0.067	5.0	76	0.311
995+00	995+02	DL	2	24	5.3	0.002	0.008	0.6	1	0.003
995+00	995+02	PL	2	24	5.3	0.002	0.008	0.6	1	0.003
1001+50	1002+20	CL	70	2	15.6	0.005	0.023	1.7	26	0.109
1004+00	1005+00	DL	100	2	22.2	0.007	0.039	2.5	38	0.156
1006+00	1010+30	CL	430	2	95.6	0.030	0.143	10.7	163	0.669
1012+50	1014+50	CL	200	2	44.4	0.014	0.067	5.0	76	0.311
1021+50	1023+50	DL	200	2	44.4	0.014	0.067	5.0	76	0.311
1026+00	1027+00	CL	100	2	22.2	0.007	0.039	2.5	38	0.156
1029+00	1030+00	CL	100	2	22.2	0.007	0.039	2.5	38	0.156
1036+00	1038+00	CL	200	2	44.4	0.014	0.067	5.0	76	0.311
1053+00	1056+00	DL	300	2	66.7	0.021	0.100	7.5	113	0.467
1073+50	1074+00	DL	50	2	11.1	0.003	0.017	1.2	19	0.078
1087+50	1089+00	DL	150	2	39.3	0.010	0.050	3.7	57	0.239
1089+50	1091+50	DL	200	2	44.4	0.014	0.067	5.0	76	0.311
1101+50	1102+00	CL	50	2	11.1	0.003	0.017	1.2	19	0.078
I-64 WB										
950+00	951+00	CL	100	2	22.2	0.007	0.039	2.5	38	0.156
955+00	957+00	CL	200	2	44.4	0.014	0.067	5.0	76	0.311
955+00	957+00	DL	200	2	44.4	0.014	0.067	5.0	76	0.311
970+00	973+00	DL	300	2	66.7	0.021	0.100	7.5	113	0.467
980+00	983+00	CL	300	2	66.7	0.021	0.100	7.5	113	0.467
982+00	985+00	CL	300	2	66.7	0.021	0.100	7.5	113	0.467
987+50	988+50	DL	100	2	22.2	0.007	0.039	2.5	38	0.156
987+50	989+50	CL	200	2	44.4	0.014	0.067	5.0	76	0.311
981+50	989+50	DL	800	2	177.8	0.056	0.267	19.9	302	1.244
989+00	991+00	DL	200	2	44.4	0.014	0.067	5.0	76	0.311
992+50	996+50	CL	400	2	88.9	0.028	0.139	10.0	151	0.622
996+50	997+00	DL	50	4	22.2	0.007	0.039	2.5	19	0.078
995+00	997+00	DL	200	2	44.4	0.014	0.067	5.0	76	0.311
997+00	998+00	CL	100	2	22.2	0.007	0.039	2.5	38	0.156
999+00	1001+00	CL	200	2	44.4	0.014	0.067	5.0	76	0.311
999+00	1001+00	DL	200	2	44.4	0.014	0.067	5.0	76	0.311
1001+00	1003+00	CL	200	2	44.4	0.014	0.067	5.0	76	0.311
1002+00	1004+00	DL	200	2	44.4	0.014	0.067	5.0	76	0.311
1005+50	1007+00	DL	150	2	39.3	0.010	0.050	3.7	57	0.239
1005+50	1007+00	CL	150	2	39.3	0.010	0.050	3.7	57	0.239
1013+00	1015+00	DL	200	2	44.4	0.014	0.067	5.0	76	0.311
1013+00	1015+00	CL	200	2	44.4	0.014	0.067	5.0	76	0.311
1018+00	1019+00	CL	100	4	44.4	0.014	0.067	5.0	38	0.156
1020+00	1022+50	CL	250	2	55.6	0.017	0.083	6.2	95	0.389
125+50	127+50	DL	200	2	44.4	0.014	0.067	5.0	76	0.311
130+00	139+50	CL	350	2	77.8	0.024	0.117	8.7	132	0.544
134+50	138+50	DL	400	2	88.9	0.028	0.139	10.0	151	0.622
139+50	142+00	CL	250	2	55.6	0.017	0.083	6.2	95	0.389
149+00	151+00	PL	200	2	44.4	0.014	0.067	5.0	76	0.311
152+00	154+00	DL	200	2	44.4	0.014	0.067	5.0	76	0.311
153+00	156+00	CL	300	2	66.7	0.021	0.100	7.5	113	0.467
157+50	158+00	DL	50	2	11.1	0.003	0.017	1.2	19	0.078
157+00	158+00	CL	100	2	22.2	0.007	0.039	2.5	38	0.156
175+00	178+50	CL	350	2	77.8	0.024	0.117	8.7	132	0.544
178+50	180+00	CL	150	2	39.3	0.010	0.050	3.7	57	0.239
1088+00	1089+00	DL	100	2	22.2	0.007	0.039	2.5	38	0.156
1090+00	1092+00	DL	200	2	44.4	0.014	0.067	5.0	76	0.311
1091+00	1092+00	CL	100	2	22.2	0.007	0.039	2.5	38	0.156
1095+00	1099+00	CL	400	2	88.9	0.028	0.139	10.0	151	0.622
1101+00	1102+00	DL	100	2	22.2	0.007	0.039	2.5	38	0.156
SUBTOTAL					2530.7	0.8	3.8	283.4	4231.8	17.4
ANTICIPATED FAILURES (+25%)					632.7	0.2	0.9	70.9	1057.9	4.4
TOTAL					3163.3	1.0	4.7	354.3	5289.7	21.8

FULL DEPTH PATCHING

STATION	LANE	LENGTH (FT)	WIDTH (FT)	CLASS A PATCHES 11 1/4"			CLASS A PATCHES 13"		PATCHING REINFORCEMENT	SAW CUTS	TIE BARS
				SQ. YD.	TYPE II	TYPE III	TYPE IV	TYPE I			
				SQ. YD.	SQ. YD.	SQ. YD.	SQ. YD.	SQ. YD.	SQ. YD.	FT.	EACH
I-64 EB											
950+00	DL	50	6	33.3			33.3		33.3	212	25
1022+00	PL	20	12	26.7			26.7		26.7	104	10
1037+50	DL	10	12	13.3				13.3	13.3	64	
1054+00	DL	10	6	6.7	6.7				6.7	52	
1085+00	DL	20	6	13.3	13.3				13.3	92	10
1090+00	DL	10	12	13.3	13.3		26.7		13.3	64	
I-64 WB											
984+00	DL	25	6	16.7		16.7			16.7	112	12.5
988+00	PL	30	6	20.0			20		20.0	132	15
985+50	DL	10	6	6.7	6.7				6.7	52	
157+00	DL	30	6	20.0			20		20.0	132	15
160+00	DL	8	6	5.3	5.3				5.3	44	
174+25	DL	10	6	6.7	6.7				6.7	52	
174+50	DL	8	6	5.3	5.3				5.3	44	
1101+00	DL	6	6	4.0				4	4.0	36	
SUBTOTAL				57.3	16.7	126.7	4.0	13.3	191.3	1192	88
ANTICIPATED FAILURES (+25%)				14.3	4.2	31.7	1.0	3.3	47.8	298	22
TOTAL				71.6	20.9	158.4	5.0	16.6	239.2	1490	109

PARTIAL DEPTH PATCHING DETAIL

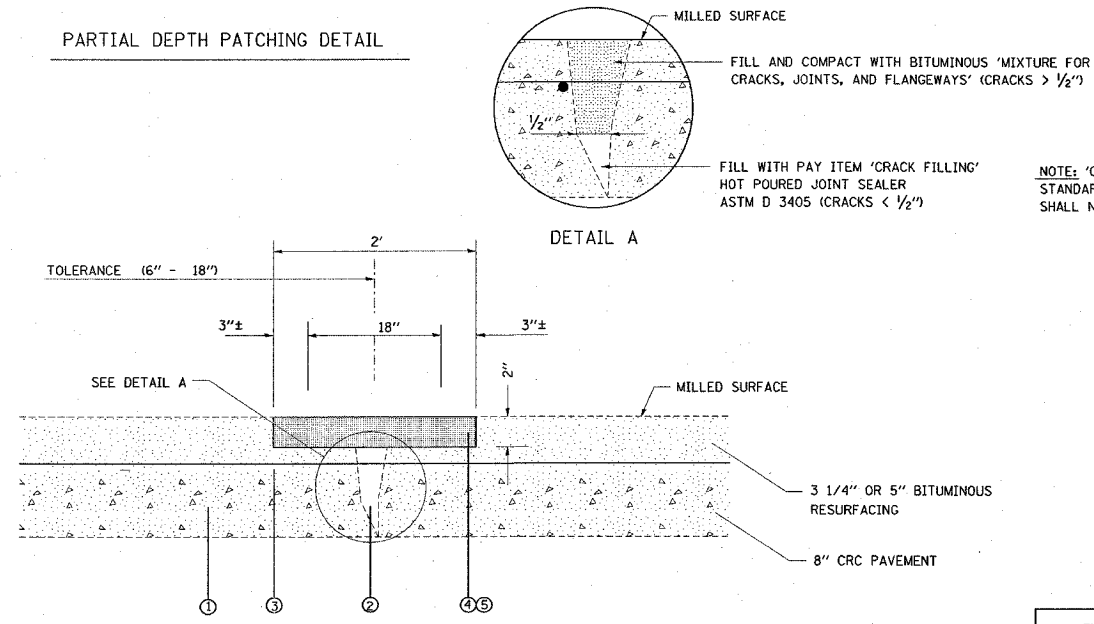

NOTE: 'CRACK FILLING' SHALL BE PER SECTION 451 OF THE STANDARD SPECIFICATIONS EXCEPT THAT 'CRACK ROUTING' SHALL NOT BE REQUIRED FOR THIS APPLICATION.

ILLINOIS DEPARTMENT OF TRANSPORTATION
PATCHING SCHEDULES AND DETAILS
 FAI ROUTE 64
 SECTION 82-BRS-1
 ST. CLAIR COUNTY

REVISIONS	
NAME	DATE

DRAWN BY: