

F.A.U. RTE.	SECTION	COUNTY	TOTAL SHEETS	SHEET NO.
7814	05-00186-01-PV	ADAMS	78	44
STA.		TO STA.		
FED. ROAD DIST. NO.		ILLINOIS FED. AID PROJECT		

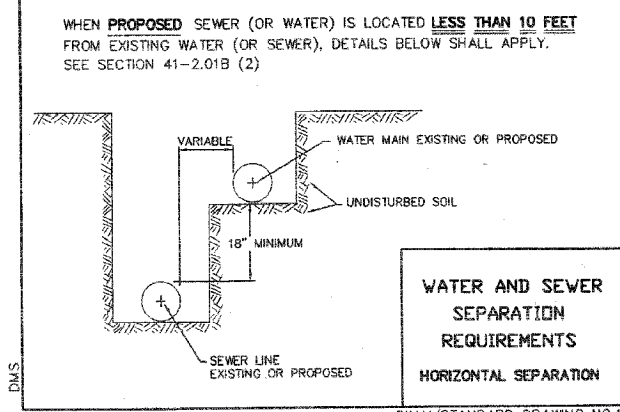

DIV.V/STANDARD DRAWING NO.18
DIV: V

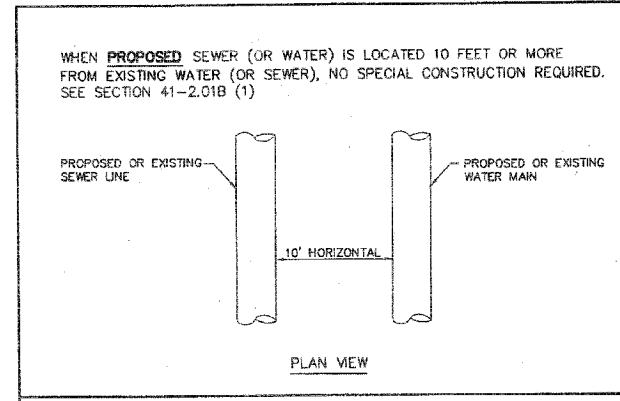
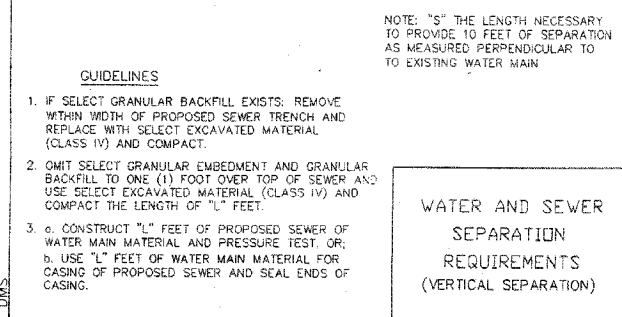
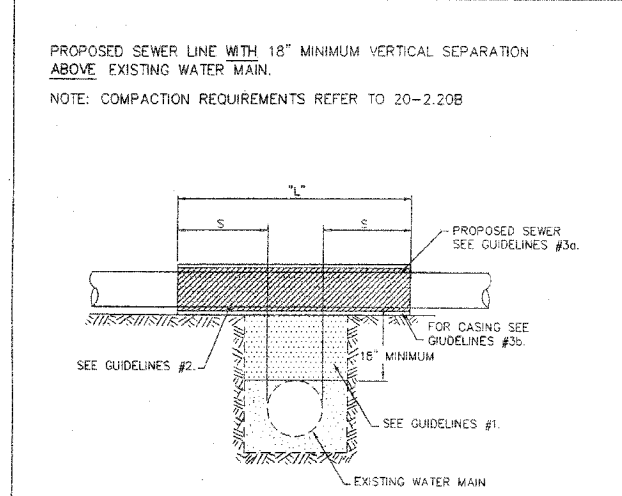

DIV.V/STANDARD DRAWING NO.19
DIV: V

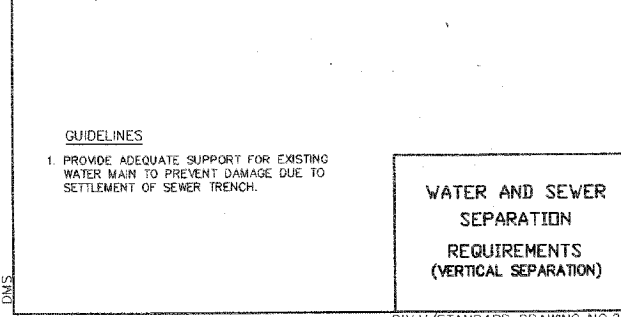
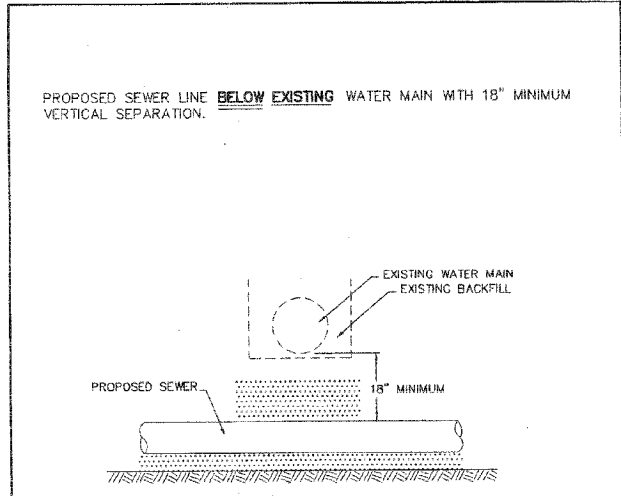

DIV.V/STANDARD DRAWING NO.20
DIV: V

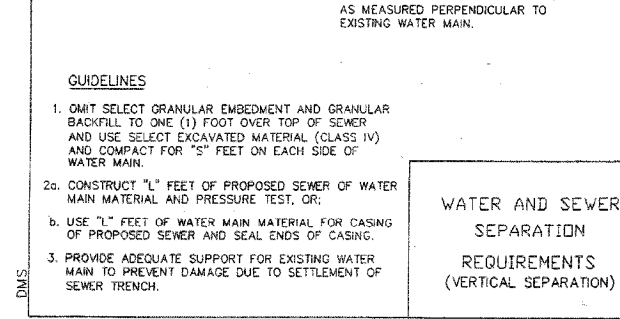
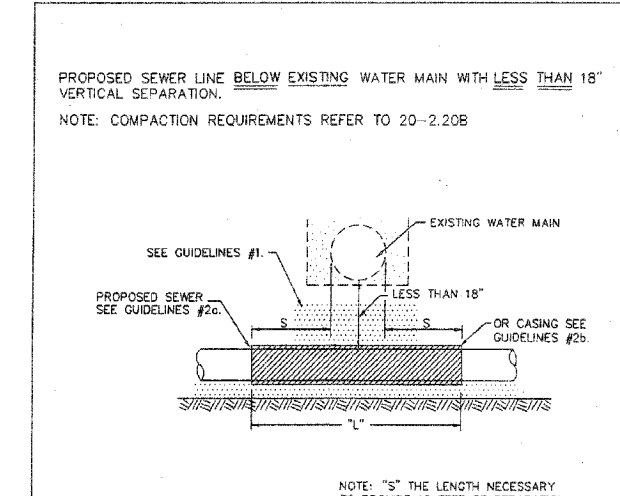

DIV.V/STANDARD DRAWING NO.21
DIV: V

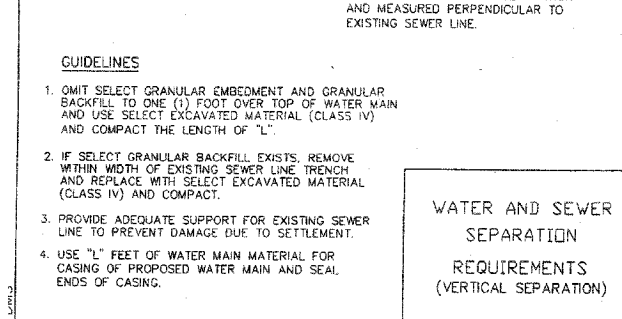
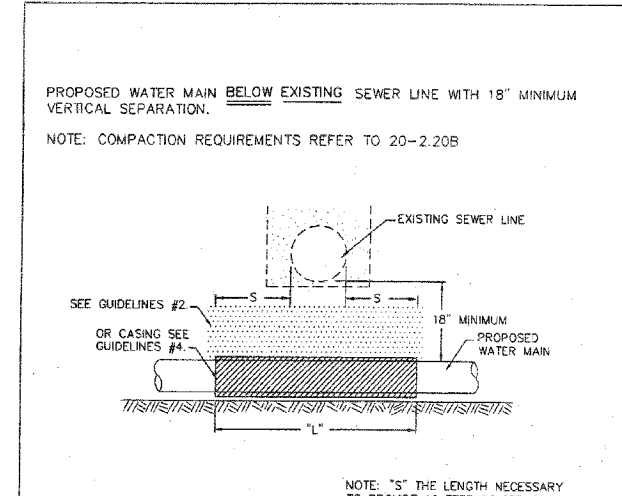

DIV.V/STANDARD DRAWING NO.23
DIV: V

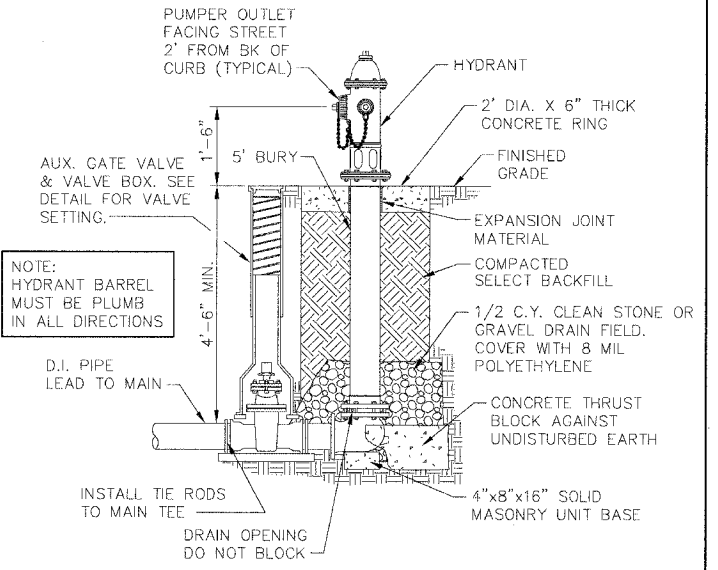
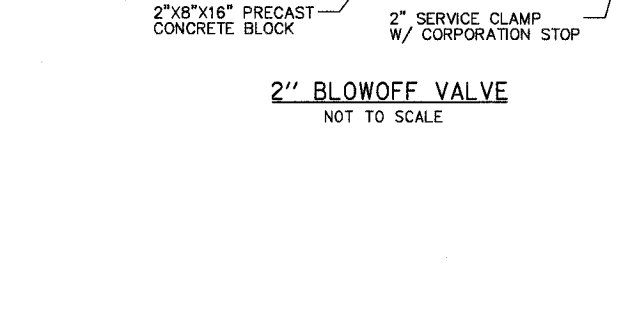
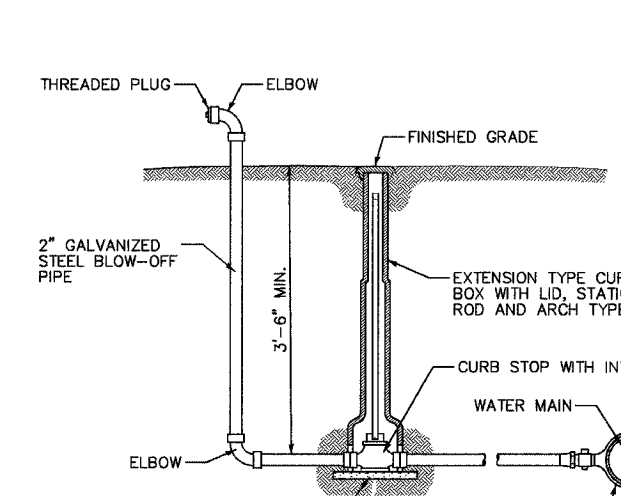

CITY OF QUINCY
FIRE HYDRANT INSTALLATION
NTS

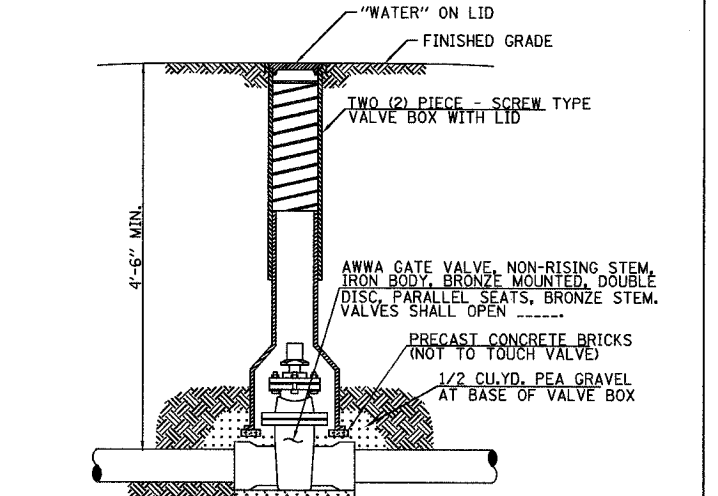

VALVE SETTING

NOT TO SCALE

REVISIONS	
NAME	DATE
TITLE BLOCK - SEB	9/26/05

MISCELLANEOUS DETAILS
WATER DETAILS
FAU 7814 (HARRISON STREET)
SECTION 05-00186-01-PV
ADAMS COUNTY

SCALE: NONE
DATE: 9/12/05
DRAWN BY: SEB
CHECKED BY: SRW

3/26/2006
P:\PROJECTS\7814\05-00186-01-PV\DWG\7814-05-00186-01-PV-44.DWG