

STATE OF ILLINOIS
 DEPARTMENT OF TRANSPORTATION
**PROPOSED
 HIGHWAY PLANS**

F.A.P. RTE. 541	SECTION 2016-022RS	COUNTY LAKE	TOTAL SHEETS 20	SHEET NO. 1
ILLINOIS			CONTRACT NO. 62C73	

D-91-380-16

FOR INDEX OF SHEETS, SEE SHEET NO. 2

THIS PROJECT IS LOCATED IN
 THE VILLAGE OF LAKE VILLA

TRAFFIC DATA

2015 ADT=11,400

SPEED LIMIT = 25-50 MPH

F.A.P. ROUTE 541: IL 132 /GRAND AVENUE
 IL 59 (GRAND AVE.) TO CLEVELAND AVENUE

SECTION: 2016-022RS

PROJECT: NHPP-0541(016)

RESURFACING (3P)

LAKE COUNTY

C-91-380-16

T 45 N / T 46 N

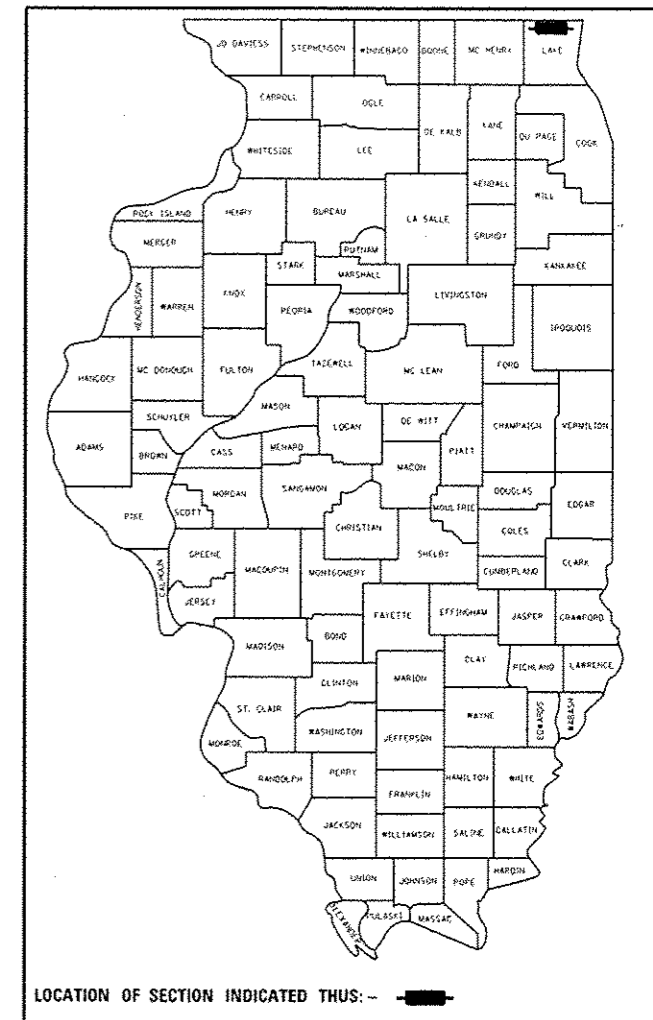

PROJECT BEGINS
 STA 10+19

OMISSION:
 STA. 43+74 TO STA. 67+74

PROJECT ENDS
 STA 107+27

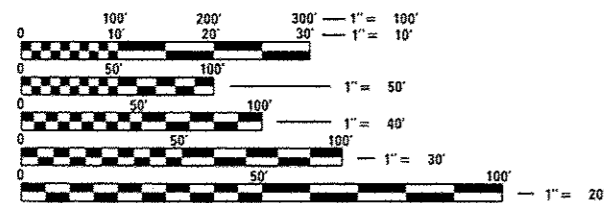

FULL SIZE PLANS HAVE BEEN PREPARED USING STANDARD ENGINEERING SCALES. REDUCED SIZED PLANS WILL NOT CONFORM TO STANDARD SCALES. IN MAKING MEASUREMENTS ON REDUCED PLANS, THE ABOVE SCALES MAY BE USED.

J.U.L.I.E.
 JOINT UTILITY LOCATION INFORMATION FOR EXCAVATION
 1-800-892-0123
 OR 811

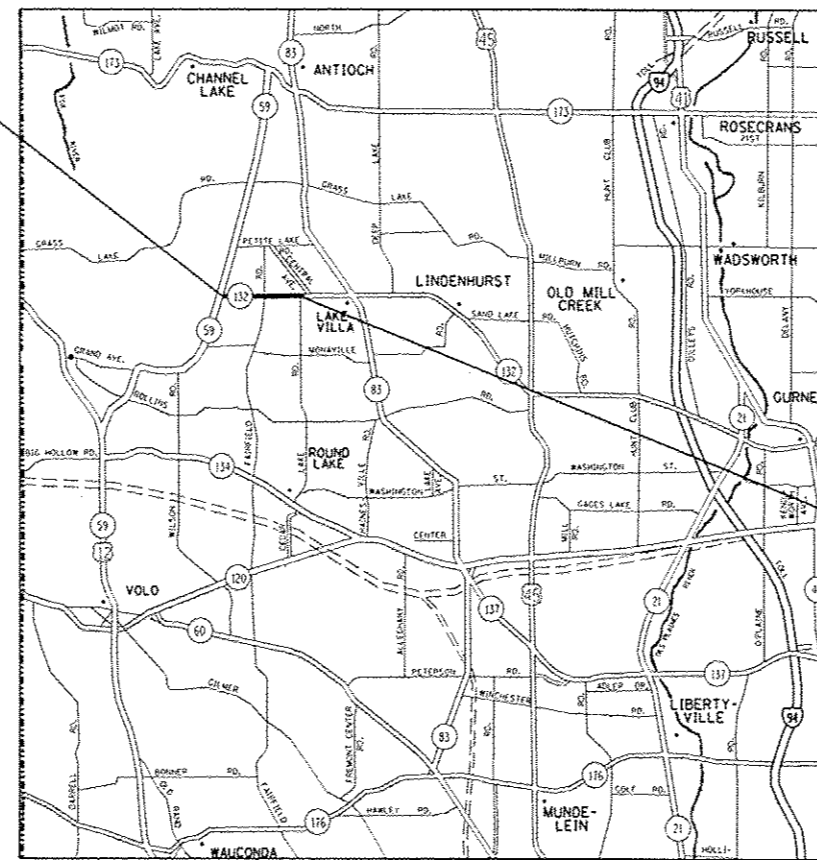

GRANT, ANTIOCH, AVON & LAKE VILLA TOWNSHIPS

GROSS LENGTH = 9,708 FT. = 1.84 MILES

NET LENGTH = 7,308 FT. = 1.38 MILES

PROJECT ENGINEER: ALAIN MIDY (847) 221-3056

PROJECT MANAGER: ISSAM RAYYAN (847) 705-4178

CONTRACT NO. 62C73

STATE OF ILLINOIS
 DEPARTMENT OF TRANSPORTATION

SUBMITTED *March 24* 20 *17*

Anthony J. Hughes REGIONAL ENGINEER

May 12 20 *17*

Margaret M. Addis ENGINEER OF DESIGN AND ENVIRONMENT

May 12 20 *17*

James J. Kelly 2 DIRECTOR OF PROGRAM DEVELOPMENT

PRINTED BY THE AUTHORITY
 OF THE STATE OF ILLINOIS

INDEX OF SHEETS

SHEET NO.	DESCRIPTION
1.	TITLE SHEET
2.	INDEX OF SHEETS, STATE STANDARDS, AND GENERAL NOTES
3-4.	SUMMARY OF QUANTITIES
5	TYPICAL SECTIONS
6-9.	ROADWAY & PAVEMENT MARKING PLANS
10	DETECTOR LOOP PLAN
11	DETAILS FOR FRAMES AND LIDS ADJUSTMENT WITH MILLING (BD-8)
12	PAVEMENT PATCHING FOR HOT-MIX ASPHALT SURFACED PAVEMENT (BD-22)
13	BUTT JOINTS AND TAPERS (BD-32)
14	TRAFFIC CONTROL AND PROTECTION FOR SIDE ROADS, INTERSECTIONS AND DRIVEWAYS (TC-10)
15	TYPICAL APPLICATIONS RAISED REFLECTIVE PAVEMENT MARKERS (SNOW PLOW RESISTANT) (TC-11)
16	DISTRICT ONE TYPICAL PAVEMENT MARKINGS (TC-13)
17	TRAFFIC CONTROL AND PROTECTION AND TURN BAYS (TO REMAIN OPEN TO TRAFFIC (TC-14)
18	SHORT TERM PAVEMENT MARKING LETTERS AND SYMBOLS
19	ARTERIAL ROAD INFORMATION SIGN (TC-22)
20	DISTRICT ONE - DETECTOR LOOP INSTALLATION DETAILS FOR ROADWAY RESURFACING (TS-07)

STATE STANDARDS

STANDARD NO	DESCRIPTION
442201-03	CLASS C AND D PATCHES
604001-04	FRAME AND LIDS, TYPE 1
701006-05	OFF-ROAD OPERATIONS 2L, 2W, 15' TO 2' FROM PAVEMENT EDGE
701301-04	LANE CLOSURE, 2L, 2W, SHORT TIME OPERATIONS
701306-03	LANE CLOSURE, 2L, 2W, SLOW MOVING OPERATIONS DAY ONLY, FOR SPEEDS > 45 MPH
701311-03	LANE CLOSURE, 2L, 2W, MOVING OPERATIONS - DAY ONLY
701336-06	LANE CLOSURE, 2L, 2W, WORK AREAS IN SERIES FOR SPEEDS > 45 MPH
701501-06	URBAN LANE CLOSURE, 2L, 2W, UNDIVIDED
701701-10	URBAN LANE CLOSURE, MULTILANE INTERSECTION
701901-06	TRAFFIC CONTROL DEVICES

GENERAL NOTES:

BEFORE STARTING ANY EXCAVATION, THE CONTRACTOR SHALL CALL "JULIE" AT 800-892-0123 OR 811 FOR FIELD LOCATIONS OF BURIED ELECTRIC, TELEPHONE AND GAS FACILITIES (48 HOUR NOTIFICATION IS REQUIRED).

THE CONTRACTOR SHALL COORDINATE CONSTRUCTION ACTIVITIES WITH UTILITY COMPANIES AND THE VILLAGE OF LAKE VILLA.

THE CONTRACTOR WILL NOT BE ALLOWED TO SET UP A YARD OR FIELD OFFICE ON STATE PROPERTY WITHOUT WRITTEN PERMISSION FROM THE DEPARTMENT.

ANY PAVEMENT MARKINGS AND RAISED REFLECTIVE PAVEMENT MARKERS OBLITERATED BY MILLING AND RESURFACING OPERATIONS ON SIDE STREETS AND ENTRANCES SHALL BE REPLACED AND PAID FOR IN KIND.

WHEN MILLED PAVEMENT IS OPEN TO TRAFFIC THE MAXIMUM GRADE DIFFERENTIAL BETWEEN PASSES OF THE MILLING MACHINE SHALL NOT EXCEED 1 1/2 INCHES (40MM) WHERE THE SPEED LIMIT IS 40 MPH (80KM/H) OR LESS AND 1 INCH (25 MM) WHERE THE SPEED LIMIT IS GREATER THAN 40 MPH (80 KM/H), WITH WRITTEN APPROVAL FROM THE ENGINEER, A MAXIMUM GRADE DIFFERENTIAL OF 3 INCHES (75 MM) MAY BE ALLOWED IF THE EDGE OF THE MILLING IS SLOPED A MINIMUM 1:3 (V:H) OR A NOTCHED LONGITUDINAL WEDGE IS USED.

BEFORE BEGINNING ANY WORK, THE CONTRACTOR SHALL RETAIN AND RECORD FOR FUTURE REFERENCE, ALL EXISTING PAVEMENT MARKING LINES AND REVISED REFLECTIVE PAVEMENT MARKERS IN ORDER THAT THESE LOCATIONS CAN BE RE-ESTABLISHED FOR STRIPING. EXACT LOCATIONS OF ALL PAVEMENT MARKINGS SHALL BE AS DIRECTED BY THE ENGINEER.

THE RESIDENT ENGINEER SHALL CONTACT WALTER CZARNY, AREA TRAFFIC FIELD ENGINEER AT ERIC.CAMPOS@ILLINOIS.GOV OR AT 847-438-2300 OR AT WALTER.CZARNY@ILLINOIS.GOV A MINIMUM OF TWO (2) WEEKS PRIOR TO THE PLACEMENT OF PERMANENT PAVEMENT MARKINGS.

DRAINAGE ADJUSTMENT OR RECONSTRUCTION LOCATIONS WILL BE DETERMINED IN THE FIELD BY THE ENGINEER.

THE CONTRACTOR SHALL CONTACT THE DISTRICT ONE TRAFFIC CONTROL SUPERVISOR AT (847) 705-4470 A MINIMUM OF 72 HOURS IN ADVANCE OF BEGINNING WORK.

IT SHALL BE THE CONTRACTOR'S RESPONSIBILITY TO VERIFY ALL DIMENSIONS AND CONDITIONS EXISTING IN THE FIELD PRIOR TO CONSTRUCTION AND ORDERING OF MATERIALS.

THE CONTRACTOR SHALL BE REQUIRED TO PROVIDE ACCESS TO ABUTTING PROPERTY AT ALL TIMES DURING THE CONSTRUCTION OF THIS PROJECT.

EXISTING BROKEN FRAMES AND LIDS SHALL BE REMOVED AND DISPOSED OF BY THE CONTRACTOR AND SHALL BE REPLACED AS DIRECTED BY THE ENGINEER. REPLACEMENT FRAMES AND LIDS WILL BE PAID FOR ACCORDING TO ARTICLE 109.04 OF THE STANDARD SPECIFICATIONS UNLESS A SEPARATE PAY ITEM HAS BEEN PROVIDED.

DO NOT SCALE PLANS FOR CONSTRUCTION DIMENSIONS.

ALL PAVEMENT PATCHING LOCATIONS WILL BE DETERMINED IN THE FIELD BY THE ENGINEER.

THESE PLANS HAVE BEEN PREPARED FROM NOTES RECEIVED FROM THE BUREAU OF CONSTRUCTION.

BUTT JOINTS WILL BE INSTALLED AT THE ENDS OF ALL RESURFACING (WHERE RESURFACING MEETS EXISTING PAVEMENT) ACCORDING TO THE "BUTT JOINT AND HOT-MIX ASPHALT TAPER DETAILS" SHEET INCLUDED IN THE PLANS, UNLESS OTHERWISE SPECIFIED.

OVERNIGHT LANE CLOSURES SHALL NOT BE ALLOWED FOR REHABILITATION PROJECTS INVOLVING DAYTIME MILLING AND RESURFACING OPERATIONS AND CLASS D PATCHING UNLESS OTHER CONDITIONS WARRANT EXTENDED LANE CLOSURES AS DETERMINED AND APPROVED IN WRITING BY THE ENGINEER OR AS PROVIDED FOR IN THE CONTRACT SPECIFICATIONS.

PAVEMENT MARKING TAPE TYPE III SHALL BE USED FOR SHORT TERM PAVEMENT MARKING ON FINAL SURFACES.

FILE NAME *	USER NAME * gwillemfp	DESIGNED -	REVISED -
\\IL084E01\INTEG\Illinois.gov\DOT\Documents\DOT Office\District 1\Projects\0132010\Drawings\Design\0132016-shv-plan.dgn		CHECKED -	REVISED -
		DATE -	DATE -

**STATE OF ILLINOIS
DEPARTMENT OF TRANSPORTATION**

**INDEX OF SHEETS, STATE STANDARDS AND GENERAL NOTES
IL 132 (IL 59 TO CLEVELAND AVE.)**

F.A.P. RTE.	SECTION	COUNTY	TOTAL SHEETS	SHEET NO.
541	2016-022RS	LAKE	20	2
CONTRACT NO. 62C73				

SUMMARY OF QUANTITIES			URBAN CONSTRUCTION TYPE CODE				
CODE NO	ITEM	UNIT	TOTAL QUANTITIES	80/20 (FED/STATE) ROADWAY 0005			
40600290	BITUMINOUS MATERIALS (TACK COAT)	POUND	15250	15250			
40600400	MIXTURE FOR CRACKS, JOINTS, AND FLANGEWAYS	TON	40	40			
40600827	POLYMERIZED LEVELING BINDER (MACHINE METHOD), IL-4.75, N50	TON	1250	1250			
40600982	HOT-MIX ASPHALT SURFACE REMOVAL - BUTT JOINT	SO YD	200	200			
40603340	HOT-MIX ASPHALT SURFACE COURSE, MIX "D", N70	TON	2530	2530			
44000161	HOT-MIX ASPHALT SURFACE REMOVAL, 3"	SO YD	22583	22583			
44201753	CLASS D PATCHES, TYPE IJ, 9 INCH	SO YD	370	370			
44201757	CLASS D PATCHES, TYPE III, 9 INCH	SO YD	220	220			
44201759	CLASS D PATCHES, TYPE IV, 9 INCH	SO YD	150	150			
48102100	AGGREGATE WEDGE SHOULDER, TYPE B	TON	475	475			
67000400	ENGINEER'S FIELD OFFICE, TYPE A	CAL MO	6	6			
67100100	MOBILIZATION	LSUM	1	1			
70100460	TRAFFIC CONTROL AND PROTECTION, STANDARD 701306	LSUM	1	1			

SUMMARY OF QUANTITIES			URBAN CONSTRUCTION TYPE CODE				
CODE NO	ITEM	UNIT	TOTAL QUANTITIES	80/20 (FED/STATE) ROADWAY 0005			
70100600	TRAFFIC CONTROL AND PROTECTION, STANDARD 701336	LSUM	1	1			
70102620	TRAFFIC CONTROL AND PROTECTION, STANDARD 701501	LSUM	1	1			
70102635	TRAFFIC CONTROL AND PROTECTION, STANDARD 701701	LSUM	1	1			
70300100	SHORT TERM PAVEMENT MARKING	FOOT	12000	12000			
70300150	SHORT TERM PAVEMENT MARKING REMOVAL	SO FT	4000	4000			
70300210	TEMPORARY PAVEMENT MARKING LETTERS AND SYMBOLS	SO FT	109.7	109.7			
70300220	TEMPORARY PAVEMENT MARKING - LINE 4"	FOOT	22330	22330			
70300240	TEMPORARY PAVEMENT MARKING - LINE 6"	FOOT	115	115			
70300250	TEMPORARY PAVEMENT MARKING - LINE 8"	FOOT	160	160			
70300260	TEMPORARY PAVEMENT MARKING - LINE 12"	FOOT	220	220			
70300280	TEMPORARY PAVEMENT MARKING - LINE 24"	FOOT	60	60			
70300520	PAVEMENT MARKING TAPE, TYPE III 4"	FOOT	6000	6000			
* 78000100	THERMOPLASTIC PAVEMENT MARKING - LETTERS AND SYMBOLS	SO FT	109.7	109.7			

* Specialty Item

FILE NAME :	USER NAME :	DESIGNED :	REVISED :
pn\N\0842EBID\ITEC\Itrats\pp\PW\DOT\Documents\DOT	quilloumef	-	-
	Office\District\Projects\038016\CAAD\Design\038016	CHECKED :	REVISED :
		-	-
		DATE :	REVISED :
		-	-

STATE OF ILLINOIS
DEPARTMENT OF TRANSPORTATION

SUMMARY OF QUANTITIES

SCALE: SHEET NO. OF SHEETS STA. TO STA.

F.A.P. RTE.	SECTION	COUNTY	TOTAL SHEETS	SHEET NO.
541	2016-022RS	LAKE	20	3
FED. ROAD DIST. NO. 1 ILLINOIS FED. AID PROJECT			CONTRACT NO. 62C73	

URBAN

URBAN

SUMMARY OF QUANTITIES			CONSTRUCTION TYPE CODE					
CODE NO	ITEM	UNIT	TOTAL QUANTITIES	80/20 (FED/STATE) ROADWAY 0005				
* 78000200	THERMOPLASTIC PAVEMENT MARKING - LINE 4"	FOOT	22330	22330				
* 78000400	THERMOPLASTIC PAVEMENT MARKING - LINE 6"	FOOT	115	115				
* 78000500	THERMOPLASTIC PAVEMENT MARKING - LINE 8"	FOOT	160	160				
* 78000600	THERMOPLASTIC PAVEMENT MARKING - LINE 12"	FOOT	220	220				
* 78000650	THERMOPLASTIC PAVEMENT MARKING - LINE 24"	FOOT	60	60				
* 78100100	RAISED REFLECTIVE PAVEMENT MARKER	EACH	200	200				
78300200	RAISED REFLECTIVE PAVEMENT MARKER REMOVAL	EACH	160	160				
* 88600600	DETECTOR LOOP REPLACEMENT	FOOT	250	250				
X2020110	GRADING AND SHAPING SHOULDERS	UNIT	135	135				
□ X5537800	STORM SEWERS TO BE CLEANED 12"	FOOT	100	100				
X6030310	FRAMES AND LIDS TO BE ADJUSTED (SPECIAL)	EACH	3	3				
12 X7030005	TEMPORARY PAVEMENT MARKING REMOVAL	SO FT	10642	10642				

SUMMARY OF QUANTITIES			CONSTRUCTION TYPE CODE					
CODE NO	ITEM	UNIT	TOTAL QUANTITIES	80/20 (FED/STATE) ROADWAY 0005				
Z0018500	DRAINAGE STRUCTURES TO BE CLEANED	EACH	10	10				
Z0030850	TEMPORARY INFORMATION SIGNING	SO FT	51.4	51.4				
* SPECIALTY ITEM								

FILE NAME :	USER NAME : gulloumef	DESIGNED -	REVISED -
D:\NUL04\BID\ITEG\11\104\p\1\1007\Documents\1\007	Office District Projects\033016\CA000\Design\1\1007	CHECKED -	REVISED -
	PLOT SCALE * 100,0000 "/ in	DATE -	REVISED -
	PLOT DATE * 3/24/2017		

**STATE OF ILLINOIS
DEPARTMENT OF TRANSPORTATION**

SUMMARY OF QUANTITIES			
SCALE:	SHEET NO.	OF SHEETS	STA. TO STA.

F.A.P. R.T.E. 541	SECTION 2016-022RS	COUNTY LAKE	TOTAL SHEETS 20	SHEET NO. 4
CONTRACT NO. 62C73				

□ NON-PARTICIPATING

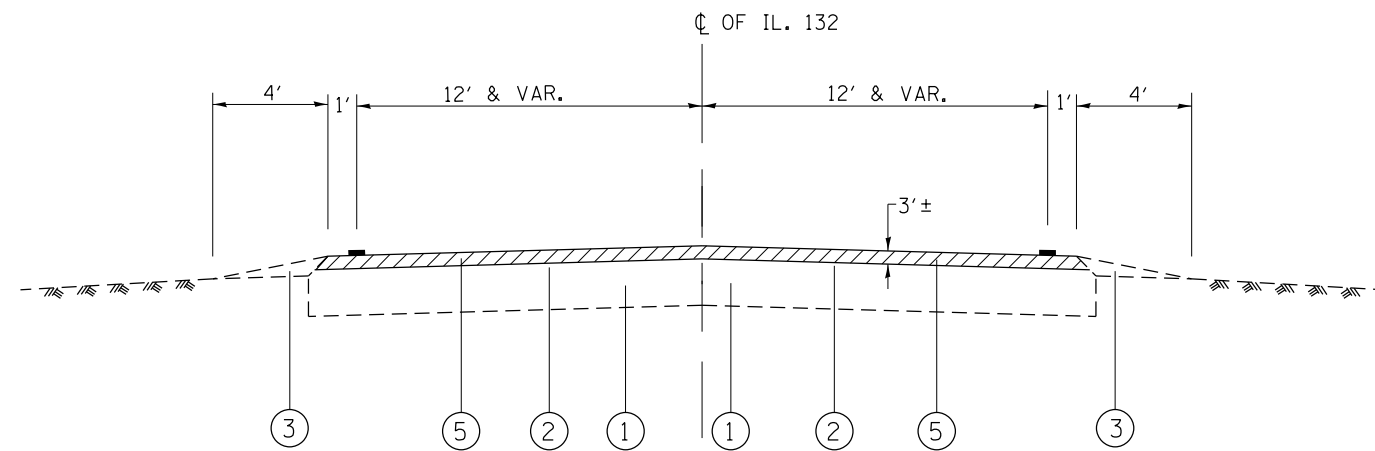

EXISTING TYPICAL SECTION
STA. 10+19 TO STA. 107+27

LEGEND

- ① EXISTING P.C.C. PAVEMENT, 9"
- ② EXISTING HMA PAVEMENT, 3"±
- ③ EXISTING AGGREGATE SHOULDER
- ④ EXISTING TYPE B-6.12 CURB & GUTTER
- ⑤ PROPOSED HMA SURFACE REMOVAL, 3"
- ⑥ PROPOSED POLYMERIZED LEVELING BINDER (MM), IL-4.75, N50, 1"
- ⑦ PROPOSED HMA SURFACE COURSE, MIX D, N70, 2"
- ⑧ PROPOSED GRADING AND SHAPING SHOULDERS
- ⑨ PROPOSED AGGREGATE WEDGE SHOULDER, TYPE B

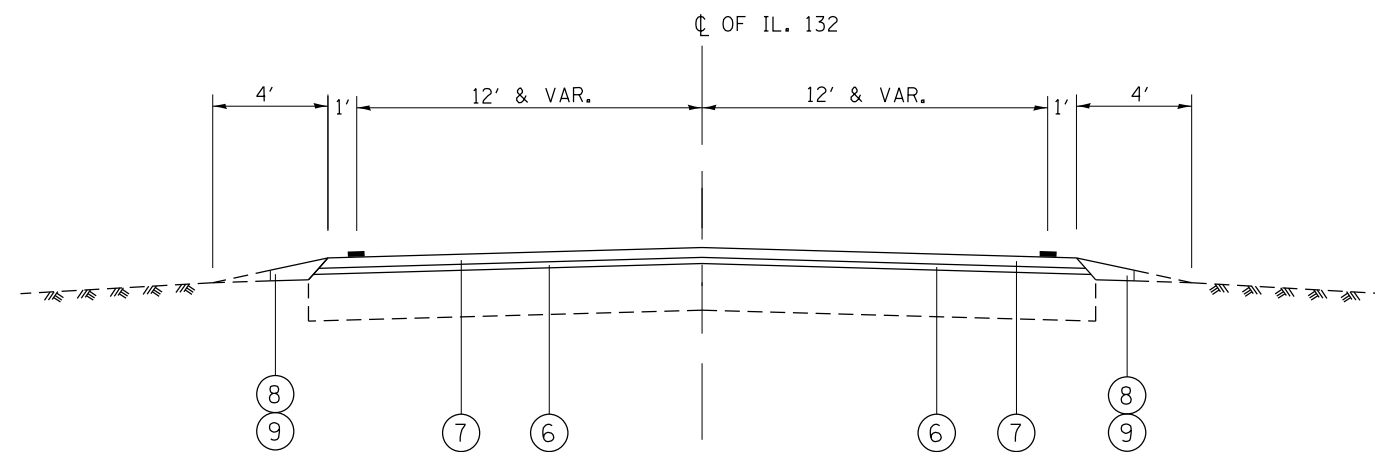

PROPOSED TYPICAL SECTION
STA. 10+19 TO STA. 107+27

MIXTURE REQUIREMENTS		QUALITY MANAGEMENT PROGRAM (QMP)
MIXTURE USES	VOIDS @ Ndes	
PAVEMENT & SHOULDER RESURFACING		
HOT-MIX ASPHALT SURFACE COURSE, MIX "D", N70 (IL 9.5 mm)	4% AT 70 GYR.	QCP
POLYMERIZED LEVELING BINDER (MACHINE METHOD), IL-4.75, N50	3.5% AT 50 GYR.	QCP
PATCHING		
CLASS D PATCHES (HMA BINDER, IL-19.0 mm)	4% AT 70 GYR.	QC/QA
QMP Designation: Quality Control/Quality Assurance (QC/QA); Quality Control for Performance (QCP); PAY FOR PERFORMANCE (PFP)		

NOTE 1: THE UNIT WEIGHT USED TO CALCULATE ALL HMA SURFACE MIXTURE QUANTITIES IS 112 LBS/SQYD/IN

NOTE 2: THE "AC TYPE" FOR POLYMERIZED HMA MIXES SHALL BE "SBS/SBR PG 76-22" AND FOR NON-POLYMERIZED HMA THE "AC TYPE" SHALL BE "PG 64-22" UNLESS MODIFIED BY DISTRICT ONE SPECIAL PROVISIONS.

FOR USE OF RECYCLED MATERIALS SEE SPECIAL PROVISIONS.

QUALITY MANAGEMENT PROGRAM (QMP) IDENTIFIES THE PARTICULAR QUALITY CONTROL SPECIFICATION THAT APPLIES TO THE HMA MIXTURE

THE CONTRACTOR SHALL MILL FIRST BEFORE PATCHING.

FILE NAME =	USER NAME = guillaumejp	DESIGNED -	REVISED -	STATE OF ILLINOIS DEPARTMENT OF TRANSPORTATION	IL. RTE. 132 (IL.59 TO CLEVELAND AVE.) TYPICAL SECTIONS	F.A.P. RTE.	SECTION	COUNTY	TOTAL SHEETS	SHEET NO.	
pw\IL084EBIDINTEG.illinois.gov\PIWIDOT\Documents\IDOT Offices\District 1\Projects\DI38016\Design\DI38016-shr-plan.dgn		CHECKED -	REVISED -			541	2016-022RS	LAKE	20	5	
PLOT SCALE = 100.0000' / in.		DATE -	REVISED -			CONTRACT NO. 62C73					
PLOT DATE = 3/24/2017						ILLINOIS FED. AID PROJECT					

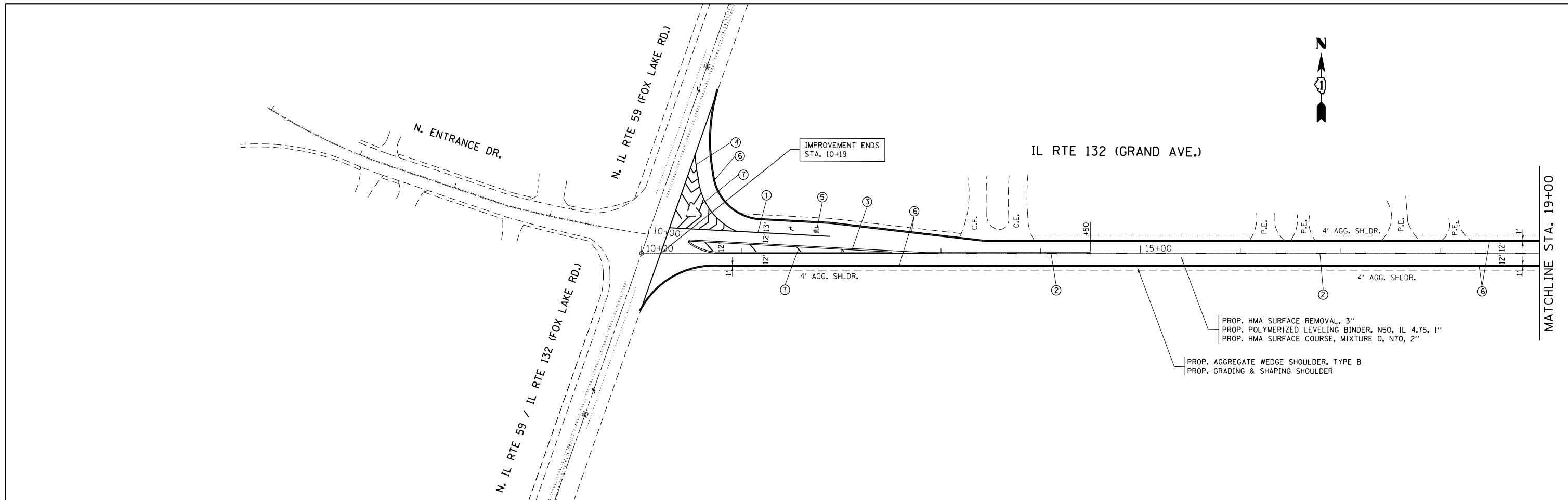

- | | |
|---|--|
| ① PROP. THERMOPLASTIC PVMT MARKING 6", WHITE (TYP.) | ⑤ PROP. THERMOPLASTIC PVMT MARKING, LETTERS AND SYMBOLS (TYP.) |
| ② PROP. THERMOPLASTIC PVMT MARKING 4", SKIP DASH, YELLOW (TYP.) | ⑥ PROP. THERMOPLASTIC PVMT. MARKING 4", WHITE (TYP.) |
| ③ PROP. THERMOPLASTIC PVMT MARKING 4", DOUBLE YELLOW (TYP.) | ⑦ PROP. THERMOPLASTIC PVMT MARKING 12", WHITE (TYP.) |
| ④ PROP. THERMOPLASTIC PVMT MARKING 8", WHITE (TYP.) | ⑧ PROP. THERMOPLASTIC PVMT MARKING 24", WHITE (TYP.) |

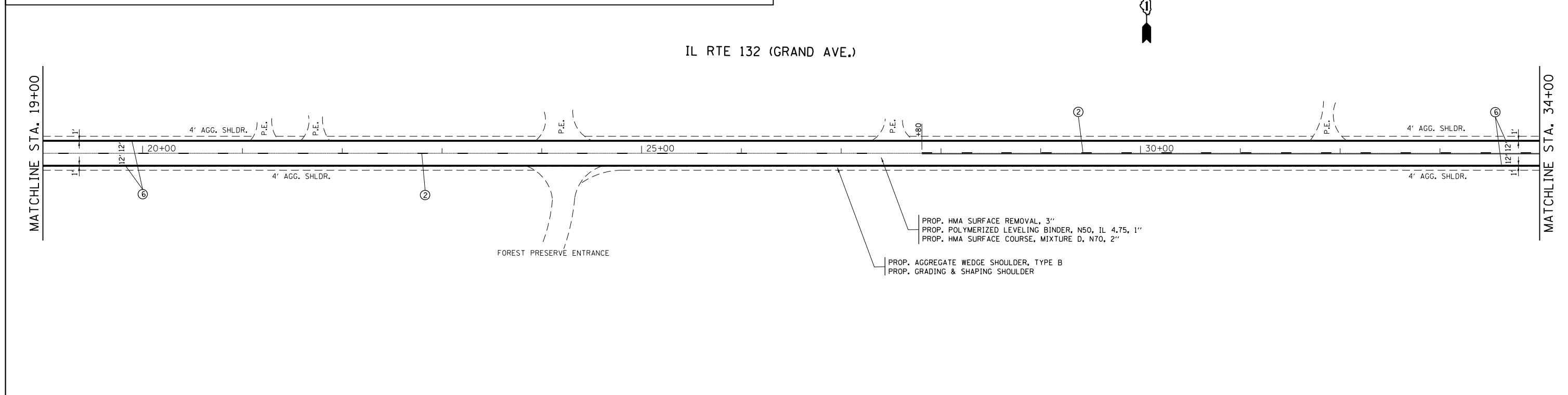

FILE NAME =	USER NAME = guillaumefp	DESIGNED -	REVISED -	STATE OF ILLINOIS DEPARTMENT OF TRANSPORTATION	EXISTING AND PROPOSED PLAN IL ROUTE 132 (IL ROUTE 59 TO CENTRAL AVE.)	F.A.P. RTE.	SECTION	COUNTY	TOTAL SHEETS	SHEET NO.
pw:\IL084EBIDINTEG\Illinois.gov\PWIDOT\Documents\IDOT Offices\District 1\Projects\DI38016\Design\DI38016-sht-pln.dgn	PLOT SCALE = 100.0000' / in.	CHECKED -	REVISED -			541	2016-022R5	LAKE	20	6
Default	PLOT DATE = 3/24/2017	DATE -	REVISED -			CONTRACT NO. 62C73			ILLINOIS FED. AID PROJECT	
						SCALE: 1"=50'	SHEET	OF	SHEETS	STA.

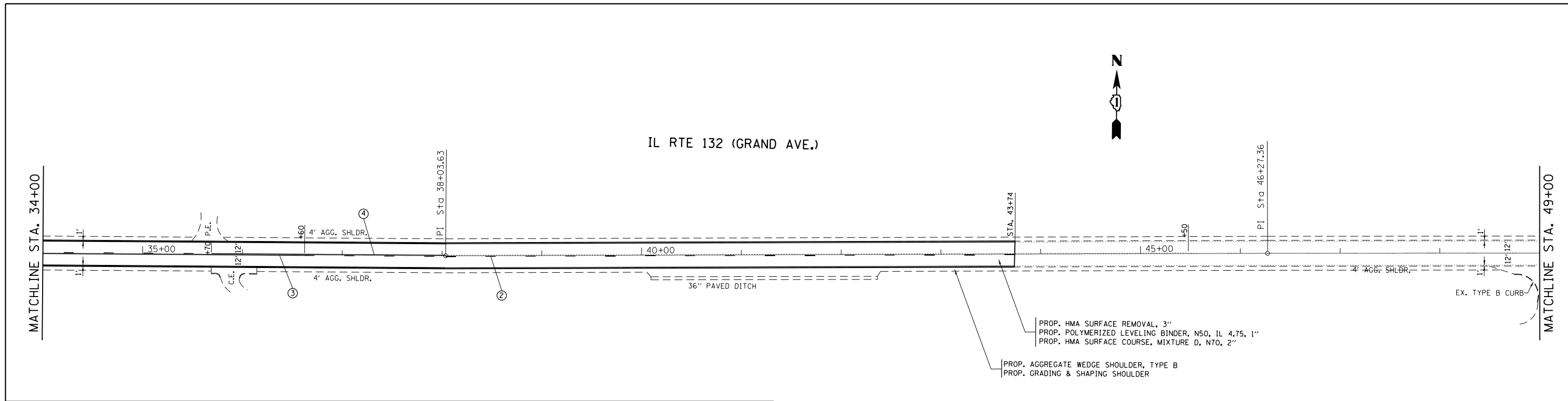

- | | |
|---|--|
| ① PROP. THERMOPLASTIC PVMT MARKING 6", WHITE (TYP.) | ⑤ PROP. THERMOPLASTIC PVMT MARKING, LETTERS AND SYMBOLS (TYP.) |
| ② PROP. THERMOPLASTIC PVMT MARKING 4", SKIP DASH, YELLOW (TYP.) | ⑥ PROP. THERMOPLASTIC PVMT. MARKING 4", WHITE (TYP.) |
| ③ PROP. THERMOPLASTIC PVMT MARKING 4", DOUBLE YELLOW (TYP.) | ⑦ PROP. THERMOPLASTIC PVMT MARKING 12", WHITE (TYP.) |
| ④ PROP. THERMOPLASTIC PVMT MARKING 8", WHITE (TYP.) | ⑧ PROP. THERMOPLASTIC PVMT MARKING 24", WHITE (TYP.) |

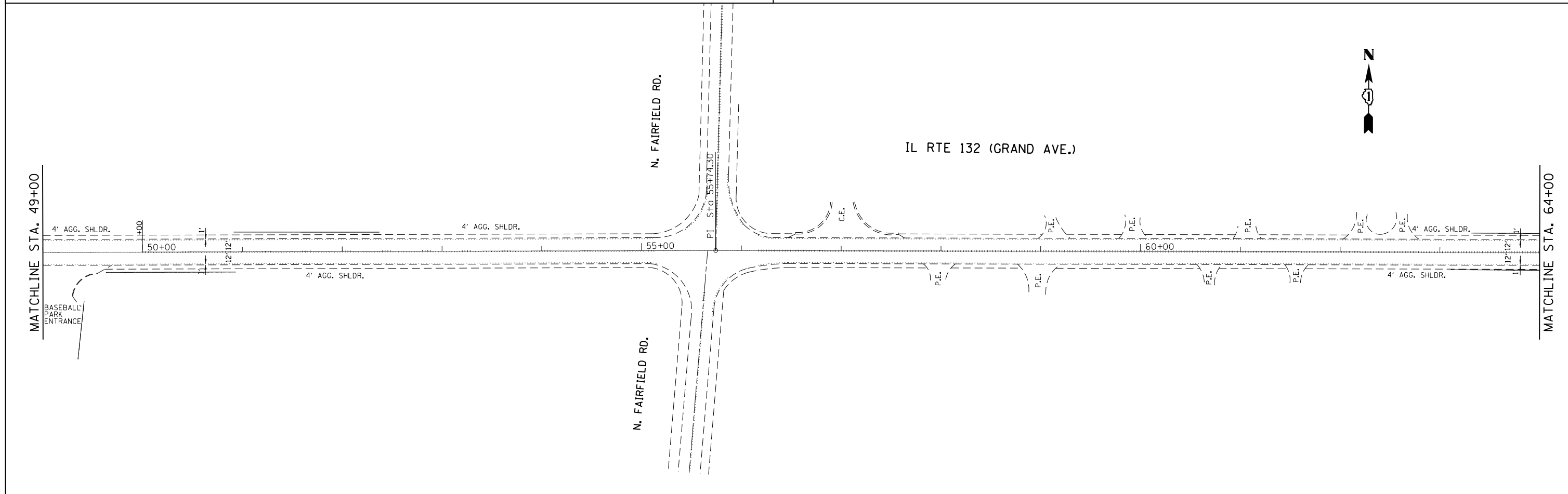

FILE NAME =	USER NAME = guillaumejp	DESIGNED -	REVISED -	STATE OF ILLINOIS DEPARTMENT OF TRANSPORTATION	EXISTING AND PROPOSED PLAN IL ROUTE 132 (IL ROUTE 59 TO CENTRAL AVE.)			F.A.P. RTE.	SECTION	COUNTY	TOTAL SHEETS	SHEET NO.
pw:\IL\084EBIDINTEG.illinois.gov\PIWIDOT\Documents\IDOT Offices\District 1\Projects\DI38016\Drawings\Design\DI38016-sht-plen.dgn		CHECKED -	REVISED -		541	2016-022R5	LAKE	20	7			
Default	PLOT SCALE = 100.0000' / in.	DATE -	REVISED -		SCALE: 1"=50'			SHEET OF SHEETS STA. TO STA.		CONTRACT NO. 62C73		
	PLOT DATE = 3/24/2017				ILLINOIS FED. AID PROJECT							

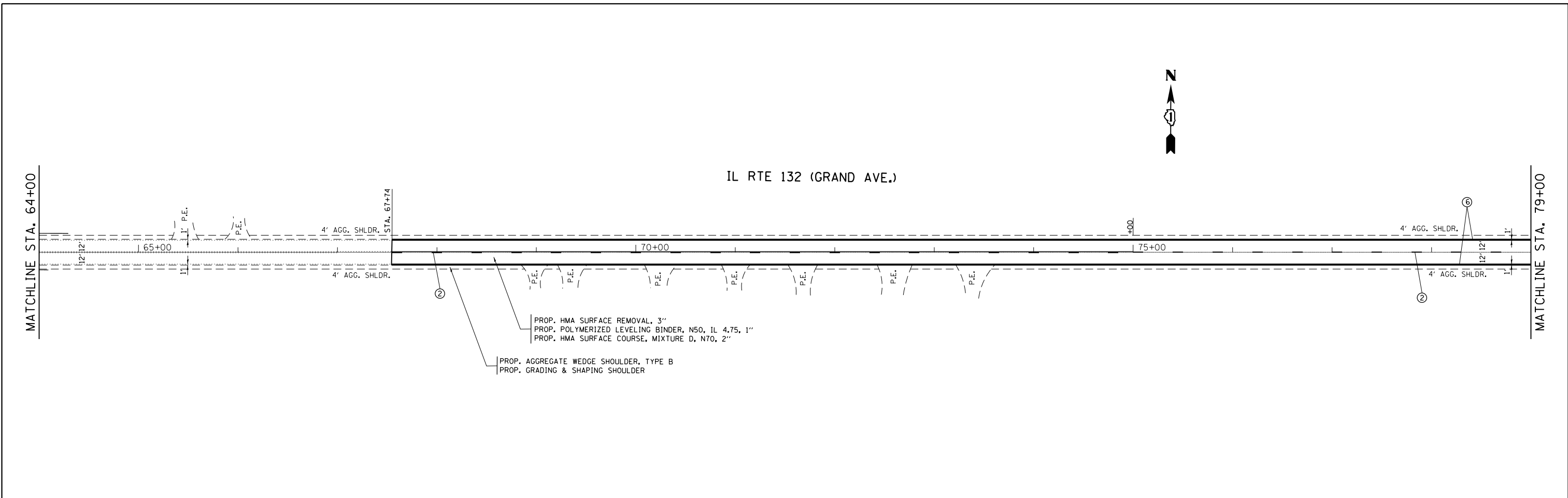

- ① PROP. THERMOPLASTIC PVMT MARKING 6", WHITE (TYP.)
- ② PROP. THERMOPLASTIC PVMT MARKING 4", SKIP DASH, YELLOW (TYP.)
- ③ PROP. THERMOPLASTIC PVMT MARKING 4", DOUBLE YELLOW (TYP.)
- ④ PROP. THERMOPLASTIC PVMT MARKING 8", WHITE (TYP.)
- ⑤ PROP. THERMOPLASTIC PVMT MARKING, LETTERS AND SYMBOLS (TYP.)
- ⑥ PROP. THERMOPLASTIC PVMT. MARKING 4", WHITE (TYP.)
- ⑦ PROP. THERMOPLASTIC PVMT MARKING 12", WHITE (TYP.)
- ⑧ PROP. THERMOPLASTIC PVMT MARKING 24", WHITE (TYP.)

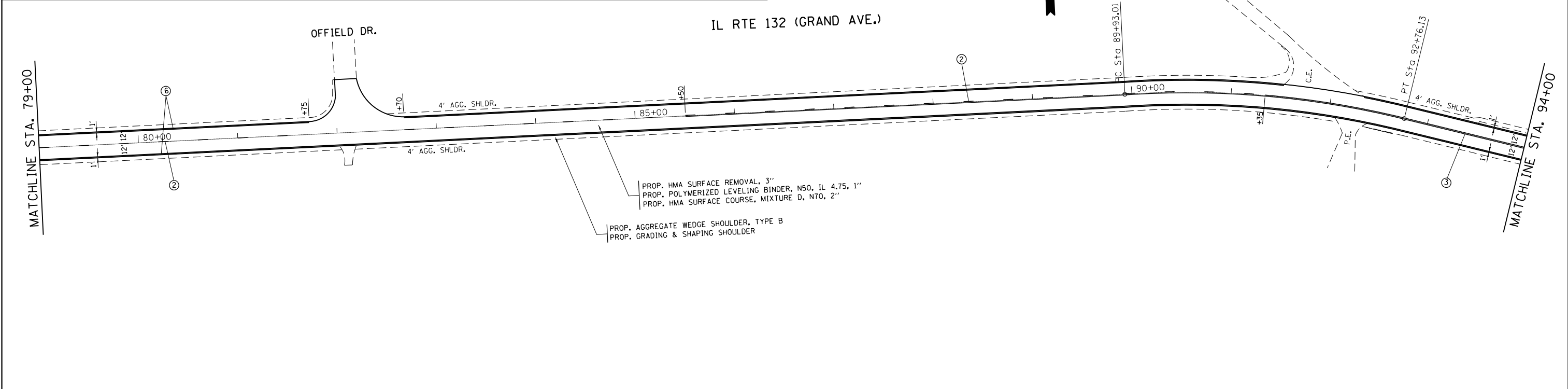

FILE NAME =	USER NAME = guillaumefp	DESIGNED -	REVISED -	STATE OF ILLINOIS DEPARTMENT OF TRANSPORTATION	EXISTING AND PROPOSED PLAN IL ROUTE 132 (IL ROUTE 59 TO CENTRAL AVE.)	F.A.P. RTE.	SECTION	COUNTY	TOTAL SHEETS	SHEET NO.	
						541	2016-022RS	LAKE	20	8	
						CONTRACT NO. 62C73					
						ILLINOIS FED. AID PROJECT					
Default	PLOT DATE = 3/24/2017	DATE -	REVISED -	SCALE: 1"=50'	SHEET OF SHEETS	STA.	TO STA.				

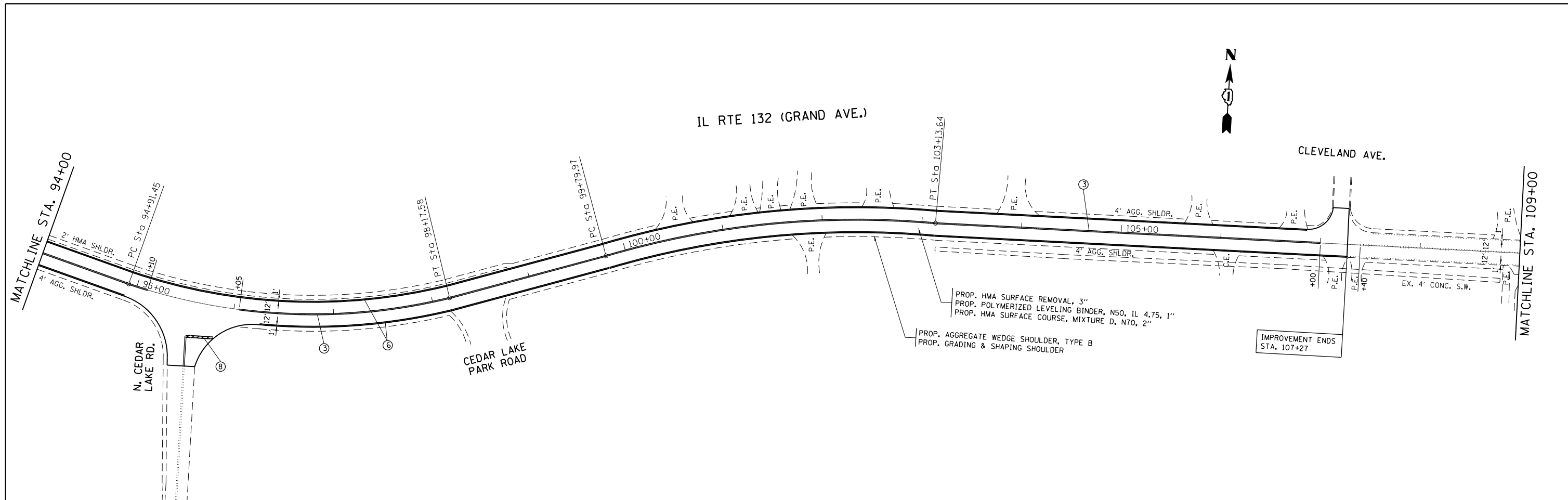

- ① PROP. THERMOPLASTIC PVMT MARKING 6", WHITE (TYP.)
- ② PROP. THERMOPLASTIC PVMT MARKING 4", SKIP DASH, YELLOW (TYP.)
- ③ PROP. THERMOPLASTIC PVMT MARKING 4", DOUBLE YELLOW (TYP.)
- ④ PROP. THERMOPLASTIC PVMT MARKING 8", WHITE (TYP.)
- ⑤ PROP. THERMOPLASTIC PVMT MARKING, LETTERS AND SYMBOLS (TYP.)
- ⑥ PROP. THERMOPLASTIC PVMT. MARKING 4", WHITE (TYP.)
- ⑦ PROP. THERMOPLASTIC PVMT MARKING 12", WHITE (TYP.)
- ⑧ PROP. THERMOPLASTIC PVMT MARKING 24", WHITE (TYP.)

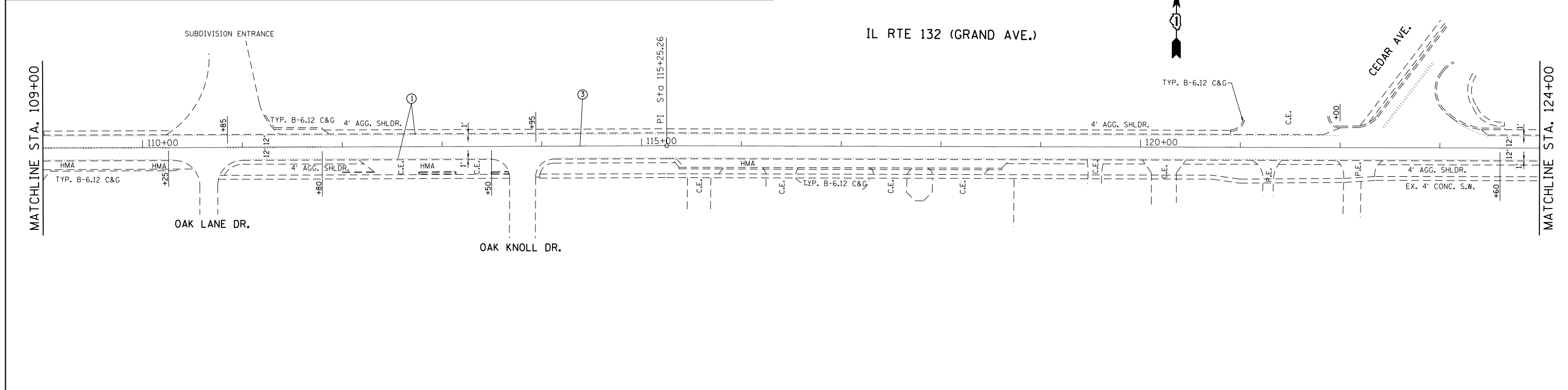

FILE NAME =	USER NAME = guillaumejp	DESIGNED -	REVISED -	STATE OF ILLINOIS DEPARTMENT OF TRANSPORTATION	EXISTING AND PROPOSED PLAN IL ROUTE 132 (IL ROUTE 59 TO CENTRAL AVE.)	F.A.P. RTE.	SECTION	COUNTY	TOTAL SHEETS	SHEET NO.
						541	2016-022R5	LAKE	20	9
						CONTRACT NO. 62C73				
Default	PLOT DATE = 3/24/2017	DATE -	REVISED -	SCALE: 1"=50'	SHEET OF SHEETS	STA. TO STA.	ILLINOIS FED. AID PROJECT			

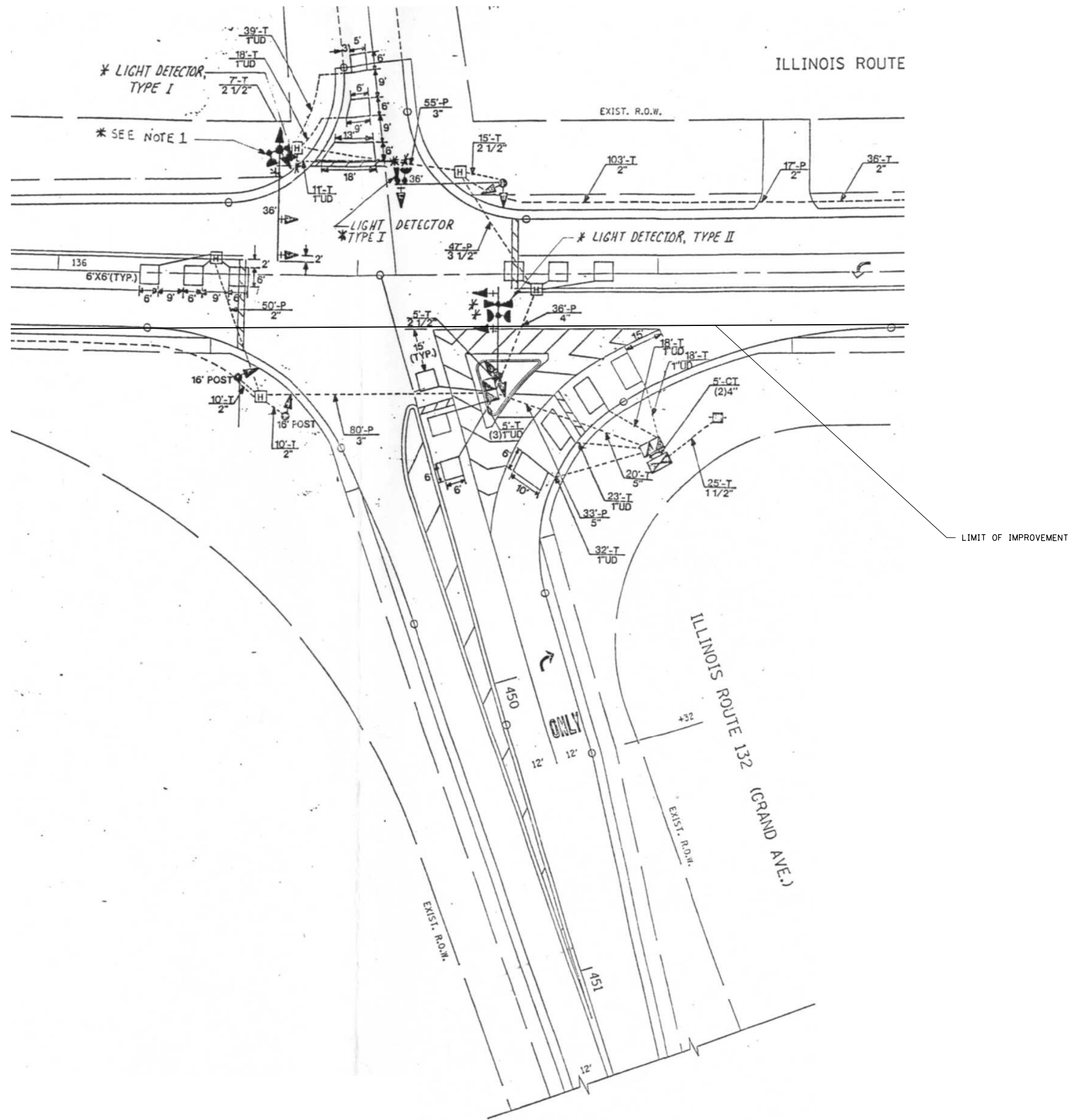

FILE NAME =	USER NAME = guillaumejp	DESIGNED -	REVISED -
p:\IL\084EBIDINTEG\illinois.gov\PWIDOT\Documents\IDOT Offices\District 1\Projects\DI38016\Design\DI38016-shr-plan.dgn		REVISED -	REVISED -
	PLOT SCALE = 100.0000' / in.	CHECKED -	REVISED -
	PLOT DATE = 3/24/2017	DATE -	REVISED -

**STATE OF ILLINOIS
DEPARTMENT OF TRANSPORTATION**

**IL ROUTE 132 AT IL 59
DETECTOR LOOP REPLACEMENT**

SCALE: 1"=50' SHEET NO. OF SHEETS STA. 10+19 TO STA. 173+70.6

F.A.P. RTE.	SECTION	COUNTY	TOTAL SHEETS	SHEET NO.
541	2016-022R5	LAKE	20	10
				CONTRACT NO. 62C73
ILLINOIS FED. AID PROJECT				

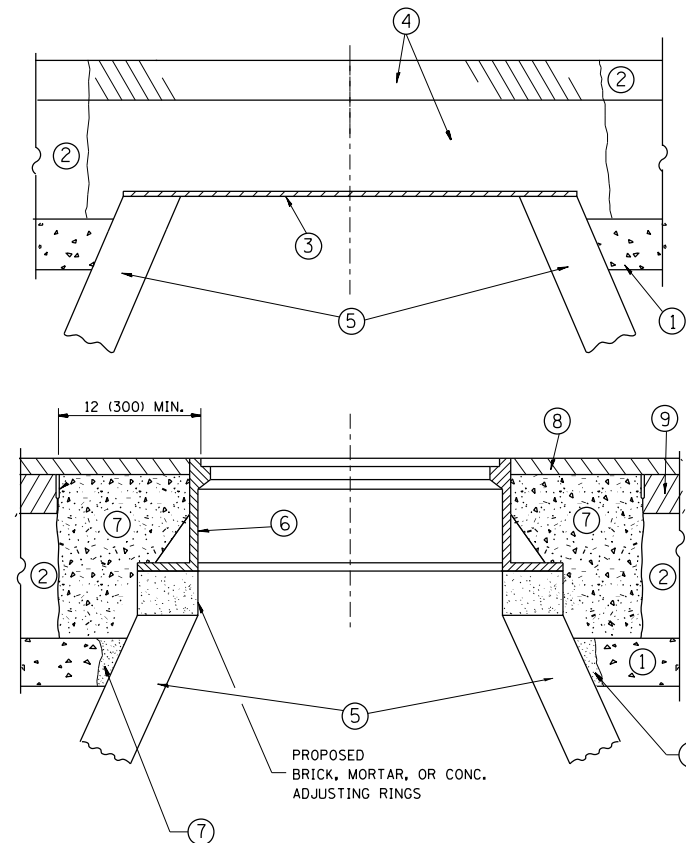

CONSTRUCTION PROCEDURES

STAGE 1 (BEFORE PAVEMENT MILLING)

- A) REMOVE A MINIMUM OF 12 (300) OF THE PAVEMENT FROM AROUND THE STRUCTURE.
- B) REMOVE THE EXISTING FRAME AND LID FROM THE STRUCTURE.
- C) COVER THE STRUCTURE OPENING WITH A 36 (900) DIAMETER METAL PLATE.
- D) BACKFILL WITH CRUSHED STONE AND A MINIMUM 1/2 (40) THICK HMA SURFACE MIX APPROVED BY THE ENGINEER.

STAGE 2 (AFTER PAVEMENT MILLING)

- A) REMOVE THE HMA SURFACE MIX AND CRUSHED STONE.
- B) INSTALL THE FRAME AND LID; ADJUST THE FRAME TO ITS FINAL SURFACE ELEVATION.
- C) THE SURROUNDING SPACE SHALL BE FILLED WITH CLASS PP-1* CONCRETE TO THE ELEVATION OF THE SURFACE OF THE EXISTING BASE COURSE OR THE BINDER COURSE.

* UNLESS OTHERWISE SPECIFIED IN THE PLANS.

THE PROCEDURE EXPLAINED ABOVE SHALL CONFORM TO THE APPLICABLE PORTIONS OF SECTIONS 353, 406, 602, AND 603 OF THE STANDARD SPECIFICATIONS EXCEPT THAT "THE CONTRACTOR SHALL ADJUST THE STRUCTURES TO THE FINISHED PAVEMENT ELEVATION NO MORE THAN 5 CALENDAR DAYS PRIOR TO PLACEMENT OF THE FINAL LIFT OF SURFACE UNLESS APPROVED BY THE ENGINEER."

LEGEND

- ① SUB-BASE GRANULAR MATERIAL
- ② EXISTING PAVEMENT
- ③ 36 (900) DIAMETER METAL PLATE
- ④ PROPOSED CRUSHED STONE AND HMA SURFACE MIX
- ⑤ EXISTING STRUCTURE
- ⑥ FRAME AND LID (SEE NOTES)
- ⑦ CLASS PP-1* CONCRETE
- ⑧ PROPOSED HMA SURFACE COURSE
- ⑨ PROPOSED HMA BINDER COURSE

LOCATION OF STRUCTURES:

THE CONTRACTOR WILL BE REQUIRED TO KEEP A RECORD OF THE LOCATIONS OF THE BURIED STRUCTURES ACCORDING TO THE STATION AND DISTANCE LEFT OR RIGHT OF THE CENTERLINE OF PAVEMENT. UPON COMPLETION OF THE WORK, THE CONTRACTOR WILL DELIVER THE RECORD TO THE ENGINEER.

BASIS OF PAYMENT:

REMOVING FRAMES AND LIDS ON DRAINAGE AND UTILITY STRUCTURES IN THE PAVEMENT PRIOR TO MILLING, AND ADJUSTING TO FINAL GRADE PRIOR TO PLACING THE SURFACE COURSE, WILL BE PAID FOR AT THE CONTRACT UNIT PRICE EACH FOR "FRAMES AND LIDS TO BE ADJUSTED (SPECIAL)."

THIS WORK WILL NOT BE PAID FOR WHEN DRAINAGE AND UTILITY STRUCTURES ARE SPECIFIED FOR PAYMENT AS STRUCTURE RECONSTRUCTION.

NEW FRAMES AND LIDS, WHEN SPECIFIED, WILL BE PAID FOR SEPARATELY.

NOTES:

EXISTING BROKEN FRAMES AND LIDS SHALL BE REMOVED AND DISPOSED OF BY THE CONTRACTOR AND SHALL BE REPLACED AS DIRECTED BY THE ENGINEER. REPLACEMENT FRAMES AND LIDS WILL BE PAID FOR IN ACCORDANCE WITH ARTICLE 109.04 OF THE STANDARD SPECIFICATIONS UNLESS A SEPARATE PAY ITEM HAS BEEN PROVIDED.

IF THE EXISTING LIDS ARE OPEN, THE FRAME WILL BE ADJUSTED TO THE ELEVATION OF THE MILLED PAVEMENT SURFACE PRIOR TO THE MILLING OPERATION. THE FRAME WILL NOT BE REMOVED AND COVERED BY THE METAL PLATE.

CITY OF CHICAGO CASTINGS ARE THE PROPERTY OF THE CITY AND THE CONTRACTOR SHALL NOTIFY THE CITY FOR REMOVAL AND DISPOSITION OF THE CASTINGS.

THE METAL PLATE USED TO COVER THE STRUCTURE SHALL REMAIN THE PROPERTY OF THE CONTRACTOR.

WHEN STRUCTURES ARE TO BE ADJUSTED OR RECONSTRUCTED, THE LOWERING AND RAISING OF THE FRAMES AND LIDS WILL NOT BE PAID FOR SEPARATELY BUT WILL BE INCLUDED IN THE COST OF THE CORRESPONDING PAY ITEM.

DETAILS FOR FRAMES AND LIDS ADJUSTMENT WITH MILLING

ALL DIMENSIONS ARE IN INCHES (MILLIMETERS) UNLESS OTHERWISE SHOWN

FILE NAME =	USER NAME = guillaumefp	DESIGNED - R. SHAH	REVISED - R. WIEDEMAN 05-14-04
pw\1\084EBIDINTEG\illinois.gov\PWIDOT\Documents\IDOT Offices\District 1\Projects\DI380\Drawings\Design\Diststd.dgn			REVISED - R. BORO 01-01-07
	PLOT SCALE = 100.0000' / in.	CHECKED -	REVISED - R. BORO 03-09-11
	PLOT DATE = 3/24/2017	DATE - 10-25-94	REVISED - R. BORO 12-06-11

**STATE OF ILLINOIS
DEPARTMENT OF TRANSPORTATION**

**DETAILS FOR
FRAMES AND LIDS ADJUSTMENT WITH MILLING**

SCALE: NONE SHEET NO. 1 OF 1 SHEETS STA. TO STA.

F.A.P. RTE.	SECTION	COUNTY	TOTAL SHEETS	SHEET NO.
541	2016-022RS	LAKE	20	11
BD600-03 (BD-8)		CONTRACT NO. 62C73		
FED. ROAD DIST. NO. 1 ILLINOIS FED. AID PROJECT				

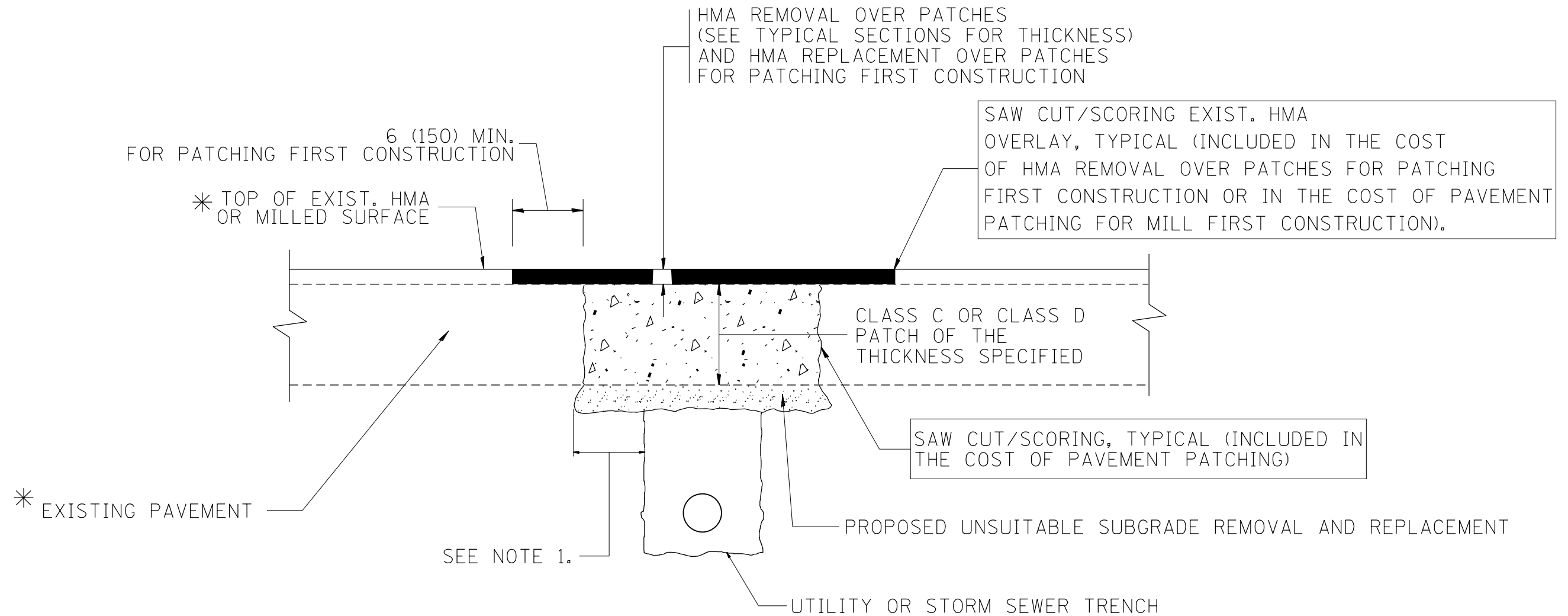

* SEE TYPICAL SECTIONS FOR THICKNESS AND MATERIALS

NOTES:

1. THE WIDTH OF THE FULL DEPTH PATCH OVER A TRENCH SHALL BE 12 (300) WIDER ON EACH SIDE OF THE TRENCH.
2. FOR METHOD OF MEASUREMENT AND BASIS OF PAYMENT, SEE RECURRING SPECIAL PROVISION "PATCHING WITH HOT-MIX ASPHALT OVERLAY REMOVAL".

SEQUENCE OF CONSTRUCTION (PATCHING FIRST)

1. REMOVE THE EXISTING HMA MATERIAL OVER THE AREA TO BE PATCHED.
2. REMOVE AND REPLACE WITH CLASS C OR D PATCH.
3. REPLACE HMA MATERIAL OVER THE AREA TO BE PATCHED.

SEQUENCE OF CONSTRUCTION (MILLING FIRST)

1. MILL HMA FIRST IF THERE IS AT LEAST 4 1/2 INCHES OR MORE OF HMA MATERIAL ON TOP OF THE EXISTING PAVEMENT OR IF THE PAVEMENT IS FULL DEPTH HMA. A MINIMUM OF 2 INCHES OF HMA MATERIAL SHALL BE IN PLACE AFTER MILLING.
2. REMOVE AND REPLACE WITH FULL DEPTH CLASS D PATCHES TO TOP OF MILLED SURFACE.

ALL DIMENSIONS ARE IN INCHES (MILLIMETERS) UNLESS OTHERWISE SHOWN.

FILE NAME =	USER NAME = guillaumejp	DESIGNED - R. SHAH	REVISED - A. ABBAS 04-27-98
pw:\IL\084EBIDINTEG\illinois.gov\PWIDOT\Documents\DOT Offices\District 1\Projects\DI380\Drawings\Design\Diststd.dgn		CHECKED -	REVISED - R. BORO 01-01-07
	PLOT SCALE = 100.0000' / 1in.	DATE - 10-25-94	REVISED - R. BORO 09-04-07
	PLOT DATE = 3/24/2017		REVISED - K. ENG 10-27-08

**STATE OF ILLINOIS
DEPARTMENT OF TRANSPORTATION**

**PAVEMENT PATCHING FOR
HMA SURFACED PAVEMENT**

SCALE: NONE SHEET NO. 1 OF 1 SHEETS STA. TO STA.

F.A.P. RTE.	SECTION	COUNTY	TOTAL SHEETS	SHEET NO.
541	2016-022RS	LAKE	20	12
BD400-04 (BD-22)			CONTRACT NO. 62C73	
FED. ROAD DIST. NO. 1 ILLINOIS FED. AID PROJECT				

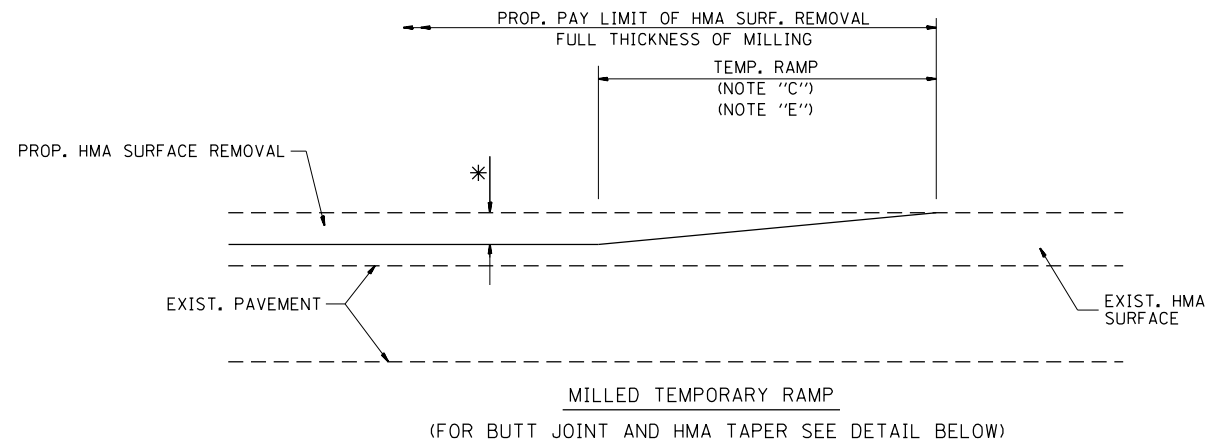

OPTION 1

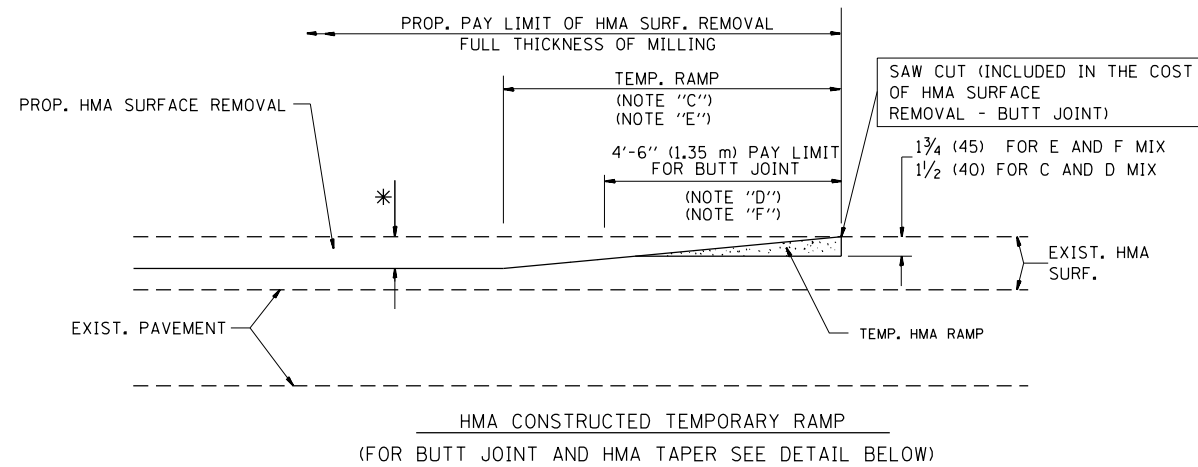

OPTION 2

TYPICAL TEMPORARY RAMP

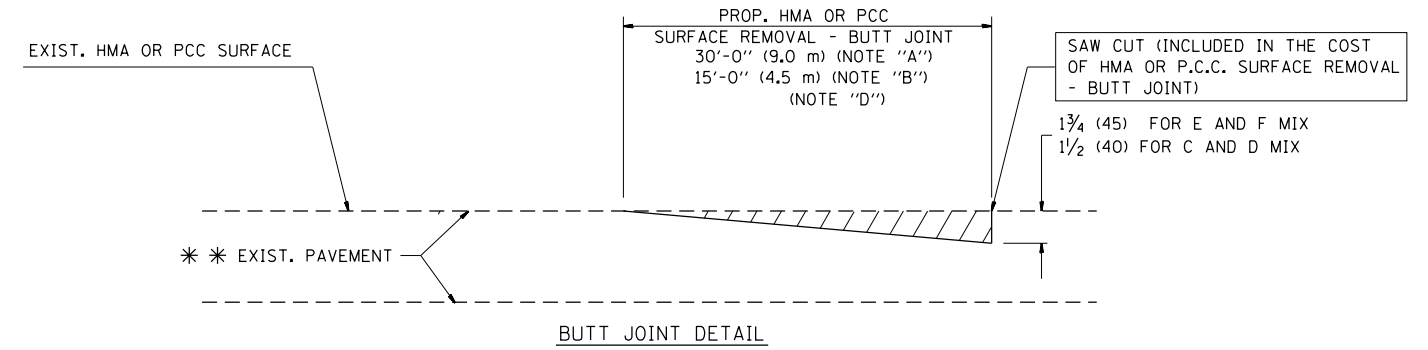

BUTT JOINT DETAIL

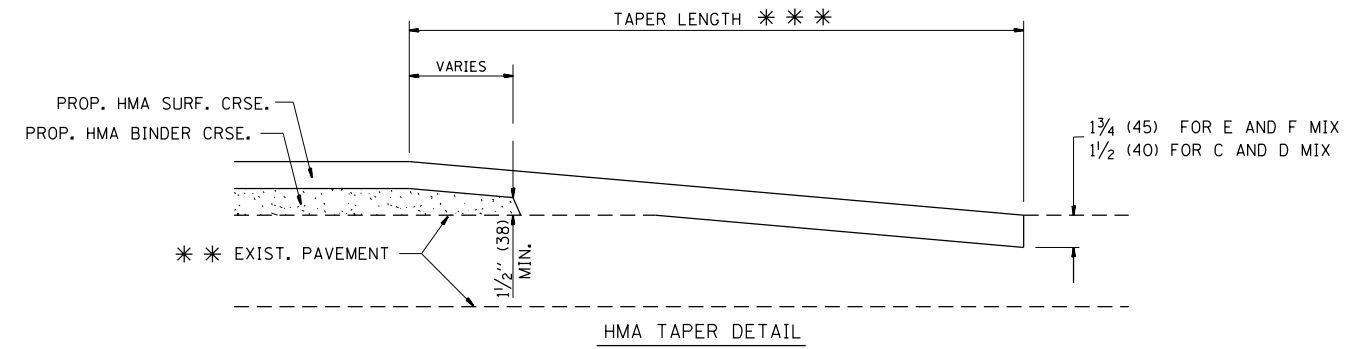

HMA TAPER DETAIL

TYPICAL BUTT JOINT AND HMA TAPER FOR RESURFACING ONLY

*** PC CONCRETE, HMA OR HMA RESURFACED PAVEMENT.

NOTES

- A: MAINLINE ROADWAYS AND MAJOR SIDE ROADS.
 - B: MINOR SIDE ROADS.
 - C: THE TEMP. RAMP SHALL BE CONSTRUCTED IMMEDIATELY UPON REMOVAL OF THE EXISTING HMA SURFACE.
 - D: THE BUTT JOINT SHALL BE CONSTRUCTED IMMEDIATELY PRIOR TO PLACING THE PROPOSED HMA COURSES.
 - E: TAPER THE TEMP. RAMP AT A RATE OF 3'-0" (900 mm) PER 1 INCH (25 mm) OF MILLING THICKNESS.
 - F: INSTALLATION AND REMOVAL OF THE 4'-6" (1.35 m) TEMP. RAMP IS INCLUDED IN COST OF HMA SURFACE REMOVAL - BUTT JOINT
 - G: SEE ARTICLE 406.08 AND 406.14 OF THE STANDARD SPECIFICATIONS FOR "HMA AND/OR PCC SURFACE REMOVAL, BUTT JOINT".
- * SEE TYPICAL SECTIONS FOR MILLING THICKNESS.
- *** 20'-0" (6.1 m) PER 1 (25) RESURFACING (NOTE "A")
10'-0" (3.0 m) PER 1 (25) RESURFACING (NOTE "B")

BASIS OF PAYMENT:

THE BUTT JOINT WILL BE PAID FOR AT THE CONTRACT UNIT PRICE PER SQUARE YARD (SQUARE METER) FOR "HOT-MIX ASPHALT SURFACE REMOVAL - BUTT JOINT" OR FOR "PORTLAND CEMENT CONCRETE SURFACE REMOVAL - BUTT JOINT".

ALL DIMENSIONS ARE IN INCHES (MILLIMETERS) UNLESS OTHERWISE SHOWN.

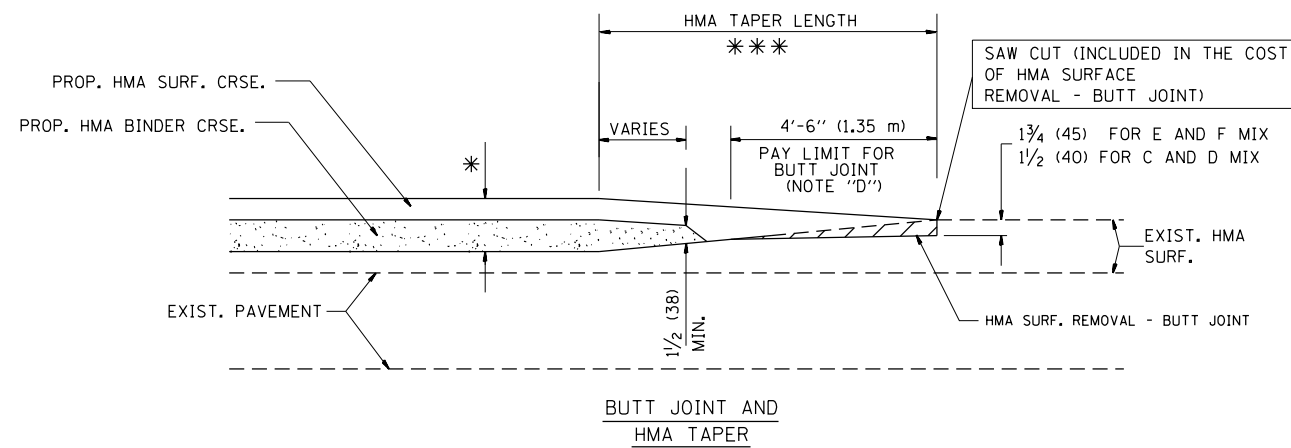

TYPICAL BUTT JOINT AND HMA TAPER FOR MILLING AND RESURFACING

FILE NAME =	USER NAME = guillaumejp	DESIGNED - M. DE YONG	REVISED - R. SHAH 10-25-94
p:\1\084EBIDINTEG.illinois.gov\PI\DOT\Documents\DOT Offices\District 1\Projects\DI380\Drawings\Design\Diststd.dgn			REVISED - A. ABBAS 03-21-97
	PLOT SCALE = 100.0000' / in.	CHECKED -	REVISED - M. GOMEZ 04-06-01
	PLOT DATE = 3/24/2017	DATE - 06-13-90	REVISED - R. BORO 01-01-07

**STATE OF ILLINOIS
DEPARTMENT OF TRANSPORTATION**

BUTT JOINT AND HMA TAPER DETAILS	
SCALE: NONE	SHEET NO. 1 OF 1 SHEETS
STA.	TO STA.

F.A.P. RTE.	SECTION	COUNTY	TOTAL SHEETS	SHEET NO.
541	2016-022RS	LAKE	20	13
BD400-05 BD32		CONTRACT NO. 62C73		
FED. ROAD DIST. NO. 1 ILLINOIS FED. AID PROJECT				

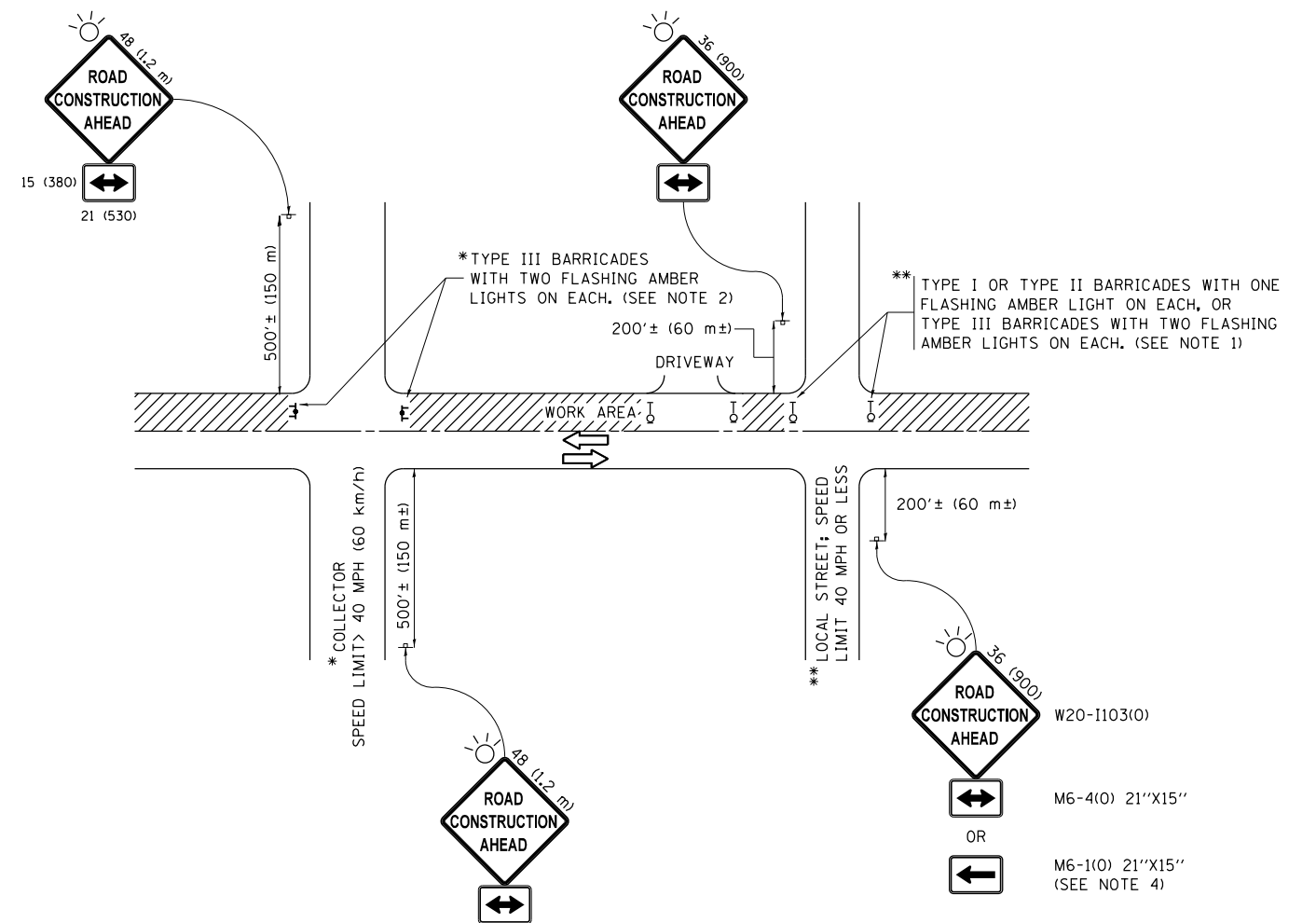

NOTES:

- SIDE ROAD WITH A SPEED LIMIT OF 40 MPH (60 km/h) OR LESS AS SHOWN ON THE DRAWING AND AS DIRECTED BY THE ENGINEER:
 - ONE "ROAD CONSTRUCTION AHEAD" SIGN 36 x 36 (900x900) WITH A FLASHER MOUNTED ON IT APPROXIMATELY 200' (60 m) IN ADVANCE OF THE MAIN ROUTE.
 - THE CLOSED PORTION OF THE MAIN ROUTE SHALL BE PROTECTED BY BLOCKING WITH TYPE I, TYPE II OR TYPE III BARRICADES, 1/3 OF THE CROSS SECTION OF THE CLOSED PORTION.
- SIDE ROAD WITH A SPEED LIMIT GREATER THAN 40 MPH (60 km/h) AS SHOWN ON THE DRAWING AND AS DIRECTED BY THE ENGINEER:
 - ONE "ROAD CONSTRUCTION AHEAD" SIGN 48 x 48 (1.2 m x 1.2 m) WITH A FLASHER MOUNTED ON IT APPROXIMATELY 500' (150 m) IN ADVANCE OF THE MAIN ROUTE.
 - THE CLOSED PORTION OF THE MAIN ROUTE SHALL BE PROTECTED BY BLOCKING WITH TYPE III BARRICADES, 1/2 OF THE CROSS SECTION OF THE CLOSED PORTION.
- CONES MAY BE SUBSTITUTED FOR BARRICADES OR DRUMS AT HALF THE SPACING DURING DAY OPERATIONS. CONES SHALL BE A MINIMUM OF 28 (710) IN HEIGHT.
- WHEN THE SIDE ROAD LIES BETWEEN THE BEGINNING OF THE MAINLINE SIGNING AND THE WORK ZONE, A SINGLE HEADED ARROW (M6-1) SHALL BE USED IN LIEU OF THE DOUBLE HEADED ARROW (M6-4).
- WHEN WORK IS BEING PERFORMED ON A SIDE ROAD OR DRIVEWAY, FOLLOW THE APPLICABLE STANDARD(S). THE DIRECTIONAL ARROW (M6-1 OR M6-4) SHALL BE COVERED OR REMOVED WHEN NO LONGER CONSISTENT WITH THE TRAFFIC CONTROL SET-UP.
- ADVANCE WARNING SIGNS ARE TO BE OMITTED ON DRIVEWAYS UNLESS OTHERWISE SPECIFIED IN THE PLANS OR BY THE ENGINEER.
- THE TRAFFIC CONTROL AND PROTECTION FOR SIDE ROADS, INTERSECTIONS, AND DRIVEWAYS SHALL BE INCLUDED IN THE COST OF SPECIFIED TRAFFIC CONTROL STANDARDS OR ITEMS.

All dimensions are in inches (millimeters) unless otherwise shown.

FILE NAME =	USER NAME = guillaumejp	DESIGNED - L.H.A.	REVISED - A. HOUSEH 10-15-96
pw:\IL\084EBIDINTEG\illinois.gov\PWIDOT\Documents\IDOT Offices\District 1\Projects\DI380\Drawings\Design\Diststd.dgn			REVISED - T. RAMMACHER 01-06-00
Default	PLOT SCALE = 100.0000' / in.	CHECKED -	REVISED - A. SCHUETZE 07-01-13
	PLOT DATE = 3/24/2017	DATE - 06-89	REVISED - A. SCHUETZE 09-15-16

**STATE OF ILLINOIS
DEPARTMENT OF TRANSPORTATION**

**TRAFFIC CONTROL AND PROTECTION FOR
SIDE ROADS, INTERSECTIONS, AND DRIVEWAYS**

SCALE: NONE SHEET 1 OF 1 SHEETS STA. TO STA.

F.A.P. RTE.	SECTION	COUNTY	TOTAL SHEETS	SHEET NO.
541	2016-022RS	LAKE	20	14
TC-10			CONTRACT NO. 62C73	
ILLINOIS FED. AID PROJECT				

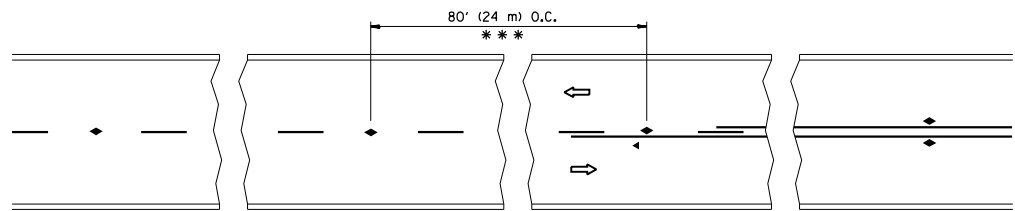

*** REDUCE TO 40' (12 m) O.C. ON CURVES WITH POSTED OR ADVISORY SPEED 45 M.P.H. (70 km/h) OR LESS.

TWO-LANE/TWO-WAY

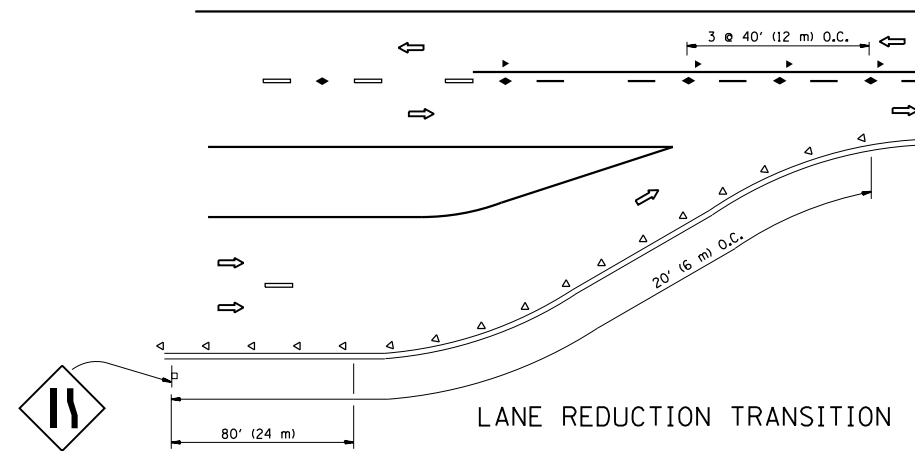

LANE REDUCTION TRANSITION

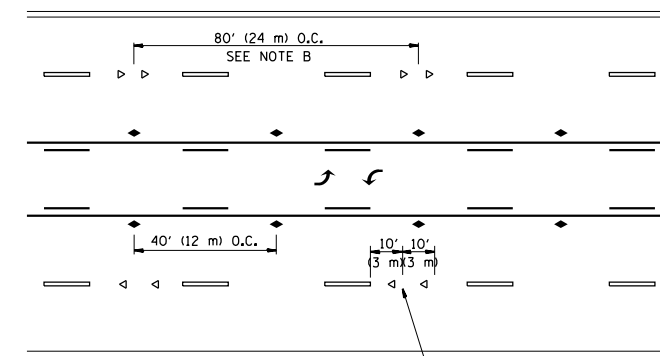

TWO-WAY LEFT TURN

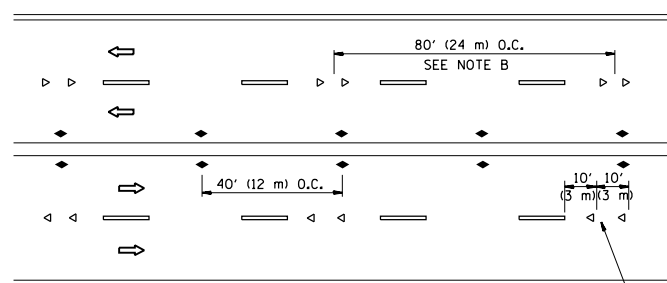

MULTI-LANE/UNDIVIDED

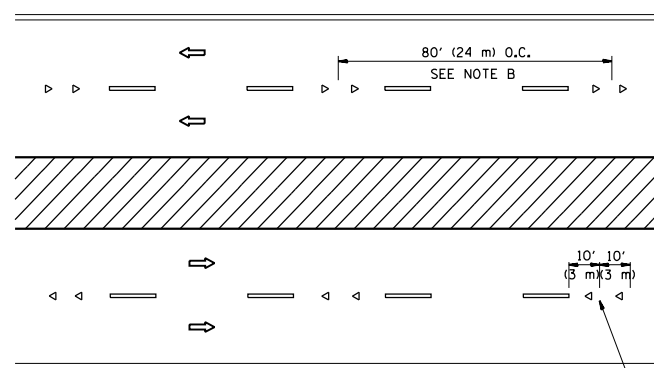

MULTI-LANE/DIVIDED

GENERAL NOTES

1. MARKERS USED WITH DASHED LINES SHALL BE CENTERED IN THE GAP BETWEEN SEGMENTS.
2. MARKERS USED ADJACENT TO SOLID LINES SHALL BE OFFSET 2 TO 3 (50 TO 75) TOWARD TRAFFIC AS SHOWN.
3. MARKERS THROUGH TANGENTS LESS THAN 500' (150 m) IN LENGTH BETWEEN CURVES SHALL BE INSTALLED AT THE LESSER OF THE TWO CURVE SPACINGS.

SYMBOLS

- YELLOW STRIPE
- WHITE STRIPE
- ◀ ONE-WAY AMBER MARKER
- ◁ ONE-WAY CRYSTAL MARKER (W/O)
- ◆ TWO-WAY AMBER MARKER

LANE MARKER NOTES

- A. USE DOUBLE LANE LINE MARKERS SPACED AS SHOWN.
- B. REDUCE TO 40' (12 m) O.C. ON CURVES WHERE ADVISORY SPEEDS ARE 10 M.P.H. (20 km/h) LOWER THAN POSTED SPEEDS.

DESIGN NOTES

1. DOUBLE LANE LINE MARKERS SHALL BE USED UNLESS SPECIFIED OTHERWISE.
2. EXCEPT AS SHOWN ON THE LANE REDUCTION TRANSITION AND FREEWAY EXIT RAMP DETAIL, MARKERS ARE NOT TO BE SPECIFIED ON RIGHT EDGE LINES.
3. THE EXACT MARKER LIMITS, SPACING, AND COLOR SHALL BE INCLUDED IN THE PLANS WHEN STANDARD SPECIFICATIONS ARE NOT BEING USED.
4. MARKERS SHOULD NOT BE USED ALONGSIDE CURBS EXCEPT FOR EXTREMELY SHORT SECTIONS OF CURBS WHERE NOT MORE THAN TWO MARKERS WOULD BE INVOLVED.

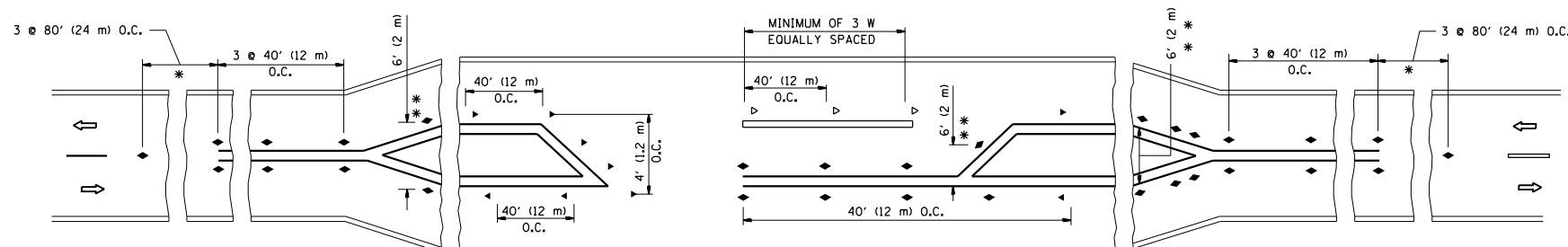

* SEE TWO-LANE/TWO-WAY WHERE MARKERS CONTINUE
 ** WHERE THE MEDIAN WIDTH IS 6' (2 m) OR LESS USE TWO-WAY MARKERS.

LEFT TURN

All dimensions are in inches (millimeters) unless otherwise shown.

FILE NAME =	USER NAME = guillaumejp	DESIGNED -	REVISED - T. RAMMACHER 09-19-94
pw:\IL\084EBIDINTEG\illinois.gov\PIWIDOT\Documents\IDOT Offices\District 1\Projects\DI380\Drawings\Design\Diststd.dgn		CHECKED -	REVISED - T. RAMMACHER 03-12-99
		DATE -	REVISED - T. RAMMACHER 01-06-00
			REVISED - C. JUCIUS 09-09-09

STATE OF ILLINOIS
DEPARTMENT OF TRANSPORTATION

TYPICAL APPLICATIONS
RAISED REFLECTIVE PAVEMENT MARKERS (SNOW-PLOW RESISTANT)

SCALE: NONE SHEET NO. 1 OF 1 SHEETS STA. TO STA.

F.A.P. RTE.	SECTION	COUNTY	TOTAL SHEETS	SHEET NO.
541	2016-022RS	LAKE	20	15
TC-11		CONTRACT NO. 62C73		
FED. ROAD DIST. NO. 1 ILLINOIS FED. AID PROJECT				

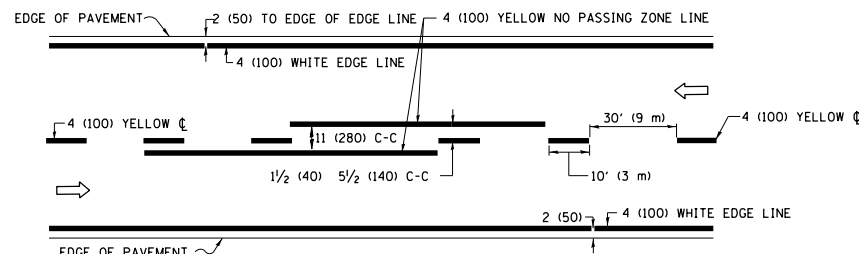

2-LANE ROADWAY

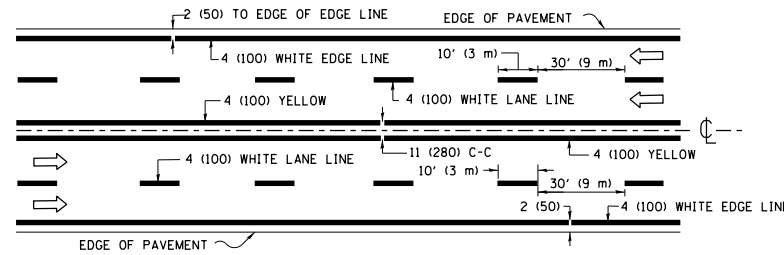

MULTI-LANE UNDIVIDED

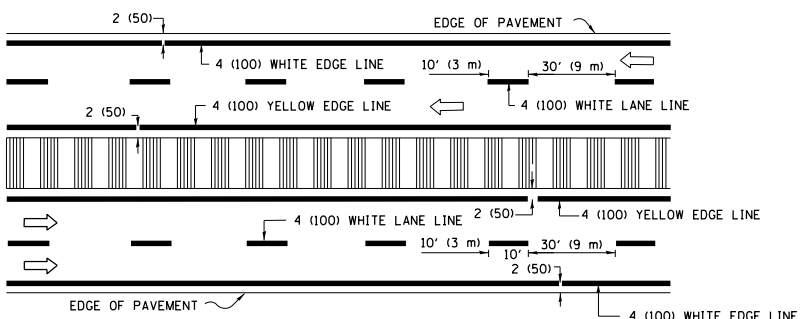

MULTI-LANE DIVIDED WITH MEDIAN

TYPICAL LANE AND EDGE LINE MARKING

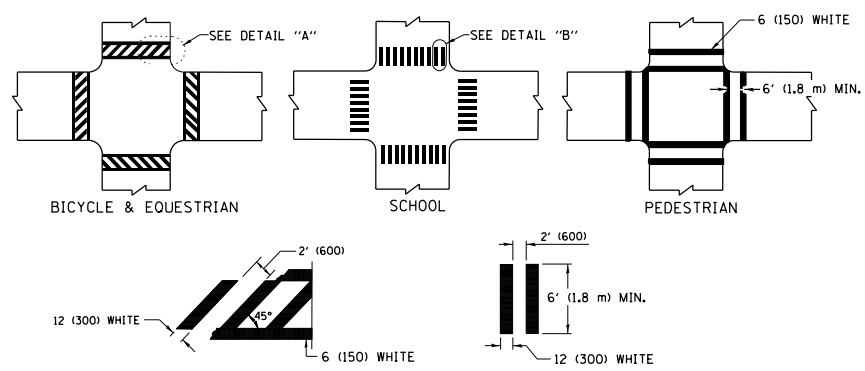

TYPICAL CROSSWALK MARKING

* MARKINGS SHALL BE INSTALLED PARALLEL TO THE CENTERLINE OF THE ROAD WHICH IT CROSSES

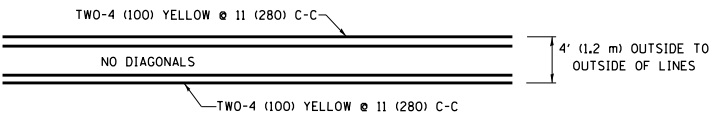

4' (1.2 m) WIDE MEDIANS ONLY

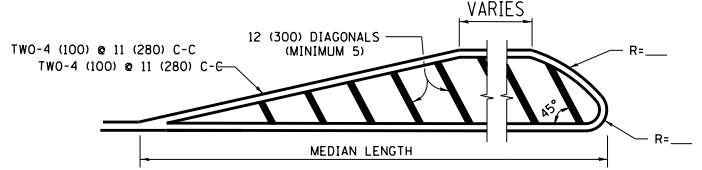

MEDIANS OVER 4' (1.2 m) WIDE

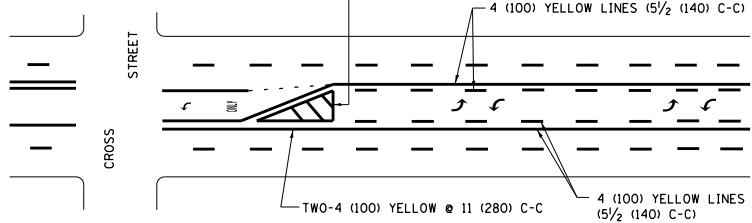

MEDIAN WITH TWO-WAY LEFT TURN LANE TYPICAL PAINTED MEDIAN MARKING

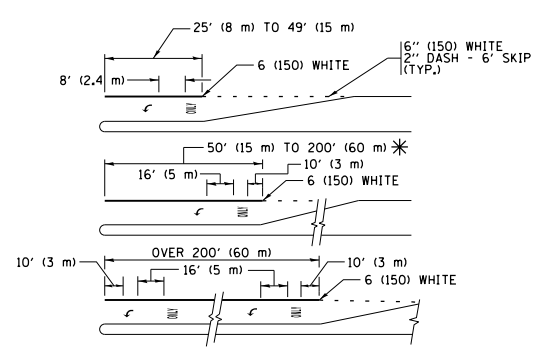

TYPICAL LEFT (OR RIGHT) TURN LANE TYPICAL TURN LANE MARKING

FULL SIZE LETTERS 8" (2.4 m) AND ARROWS SHALL BE USED. AREA = 15.6 SQ. FT. (1.5 m²) ONLY AREA = 20.8 SQ. FT. (1.9 m²) TURN LANES IN EXCESS OF 400' (120 m) IN LENGTH MAY HAVE AN ADDITIONAL SET OF ARROW - "ONLY" INSTALLED MIDWAY BETWEEN THE OTHER TWO SETS OF ARROW - "ONLY".

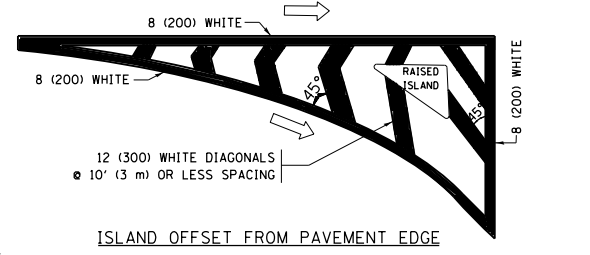

ISLAND OFFSET FROM PAVEMENT EDGE

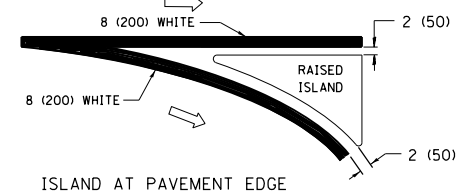

ISLAND AT PAVEMENT EDGE TYPICAL ISLAND MARKING

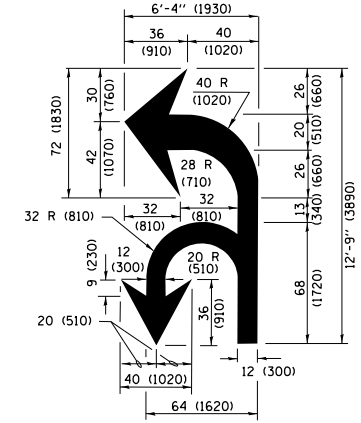

COMBINATION LEFT AND U-TURN

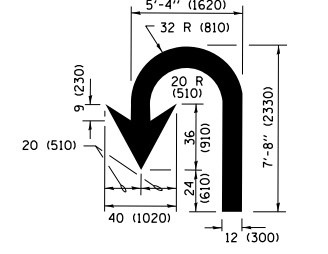

U-TURN

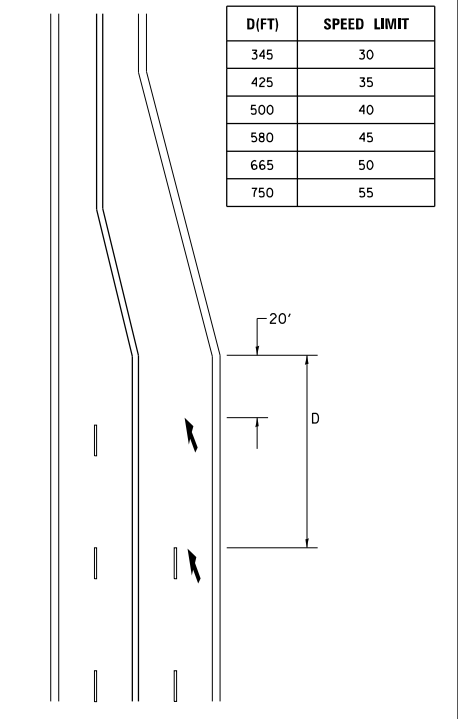

LANE REDUCTION TRANSITION

* LANE REDUCTION ARROWS REQUIRED AT SPEEDS OF 45 MPH OR GREATER OR WHEN SPECIFIED IN PLANS.

TYPE OF MARKING	WIDTH OF LINE	PATTERN	COLOR	SPACING /REMARKS
CENTERLINE ON 2 LANE PAVEMENT	4 (100)	SKIP-DASH	YELLOW	10' (3 m) LINE WITH 30' (9 m) SPACE
CENTERLINE ON MULTI-LANE UNDIVIDED PAVEMENT	2 @ 4 (100)	SOLID	YELLOW	11 (280) C-C
NO PASSING ZONE LINES: FOR ONE DIRECTION FOR BOTH DIRECTIONS	4 (100) 2 @ 4 (100)	SOLID SOLID	YELLOW YELLOW	5/2 (140) C-C FROM SKIP-DASH CENTERLINE 11 (280) C-C OMIT SKIP-DASH CENTERLINE BETWEEN
LANE LINES	4 (100) 5 (125) ON FREEWAYS	SKIP-DASH SKIP-DASH	WHITE WHITE	10' (3 m) LINE WITH 30' (9 m) SPACE
DOTTED LINES (EXTENSIONS OF CENTER, LANE OR TURN LANE MARKINGS)	SAME AS LINE BEING EXTENDED	SKIP-DASH	SAME AS LINE BEING EXTENDED	2' (600) LINE WITH 6' (1.8 m) SPACE
EDGE LINES	4 (100)	SOLID	YELLOW-LEFT WHITE-RIGHT	OUTLINE MEDIANS IN YELLOW
TURN LANE MARKINGS	6 (150) LINE; FULL SIZE LETTERS & SYMBOLS (8" (2.4m))	SOLID	WHITE	SEE TYPICAL TURN LANE MARKING DETAIL
TWO WAY LEFT TURN MARKING	2 @ 4 (100) EACH DIRECTION 8' (2.4m) LEFT ARROW	SKIP-DASH AND SOLID IN PAIRS	YELLOW WHITE	10' (3 m) LINE WITH 30' (9 m) SPACE FOR SKIP-DASH; 5/2 (140) C-C BETWEEN SOLID LINE AND SKIP-DASH LINE SEE TYPICAL TWO-WAY LEFT TURN MARKING DETAIL
CROSSWALK LINES (PEDESTRIAN) A. DIAGONALS (BIKE & EQUESTRIAN) B. LONGITUDINAL BARS (SCHOOL)	2 @ 6 (150) 12 (300) @ 45° 12 (300) @ 90°	SOLID SOLID SOLID	WHITE WHITE WHITE	NOT LESS THAN 6' (1.8 m) APART 2' (600) APART 2' (600) APART SEE TYPICAL CROSSWALK MARKING DETAILS.
STOP LINES	24 (600)	SOLID	WHITE	PLACE 4' (1.2 m) IN ADVANCE OF AND PARALLEL TO CROSSWALK, IF PRESENT, OTHERWISE, PLACE AT DESIRED STOPPING POINT. PARALLEL TO CROSSROAD CENTERLINE, WHERE POSSIBLE.
PAINTED MEDIANS	2 @ 4 (100) WITH 12 (300) DIAGONALS @ 45° NO DIAGONALS USED FOR 4' (1.2 m) WIDE MEDIANS	SOLID	YELLOW; TWO WAY TRAFFIC WHITE; ONE WAY TRAFFIC	11 (280) C-C FOR THE DOUBLE LINE SEE TYPICAL PAINTED MEDIAN MARKING.
GORE MARKING AND CHANNELIZING LINES	8 (200) WITH 12 (300) DIAGONALS @ 45°	SOLID	WHITE	DIAGONALS: 15' (4.5 m) C-C (LESS THAN 30MPH (50 km/h)) 20' (6 m) C-C 30MPH (50 km/h) TO 45MPH (70 km/h) 30' (9 m) C-C (OVER 45MPH (70 km/h))
RAILROAD CROSSING	24 (600) TRANSVERSE LINES; "RR" IS 6' (1.8 m) LETTERS; 16 (400) LINE FOR "X"	SOLID	WHITE	SEE STATE STANDARD 780001 AREA OF: "R"=3.6 SQ. FT. (0.33 m ²) EACH "X"=54.0 SQ. FT. (5.0 m ²)
SHOULDER DIAGONALS (REQUIRED FOR SHOULDERS ≥ 8')	12 (300) @ 45°	SOLID	WHITE - RIGHT YELLOW - LEFT	50' (15 m) C-C (LESS THAN 30MPH (50 km/h)) 75' (22.5 m) C-C (30 MPH (50 km/h) TO 45MPH (70 km/h)) 150' (45 m) C-C (OVER 45MPH (70 km/h))
U TURN ARROW	SEE DETAIL	SOLID	WHITE	16.3 SF
2 ARROW COMBINATION LEFT AND U TURN	SEE DETAIL	SOLID	WHITE	30.4 SF

FOR FURTHER DETAILS ON PAVEMENT MARKING REFER TO STANDARD SPECIFICATIONS FOR ROAD AND BRIDGE CONSTRUCTION AND STATE STANDARD 780001.

All dimensions are in inches (millimeters) unless otherwise shown.

FILE NAME =	USER NAME = guillaumejp	DESIGNED - EVERS	REVISED - C. JUCIUS 09-09-09
pw\jll084EBIDINTEG\illinois.gov\PWIDOT\Documents\DOT Offices\District 1\Projects\01380\01380\Design\Diststd.dgn			REVISED - C. JUCIUS 07-01-13
Default	PLOT SCALE = 100.0000' / in.	CHECKED -	REVISED - C. JUCIUS 12-21-15
	PLOT DATE = 3/24/2017	DATE - 03-19-90	REVISED - C. JUCIUS 04-12-16

STATE OF ILLINOIS DEPARTMENT OF TRANSPORTATION

DISTRICT ONE TYPICAL PAVEMENT MARKINGS			
SCALE: NONE	SHEET 1 OF 1 SHEETS	STA. TO STA.	

F.A.P RTE. 541	SECTION 2016-022RS	COUNTY LAKE	TOTAL SHEETS 20	SHEET NO. 16
TC-13		CONTRACT NO. 62C73		
ILLINOIS FED. AID PROJECT				

TURN BAY ENTRANCE AT START OF LANE CLOSURE TAPER

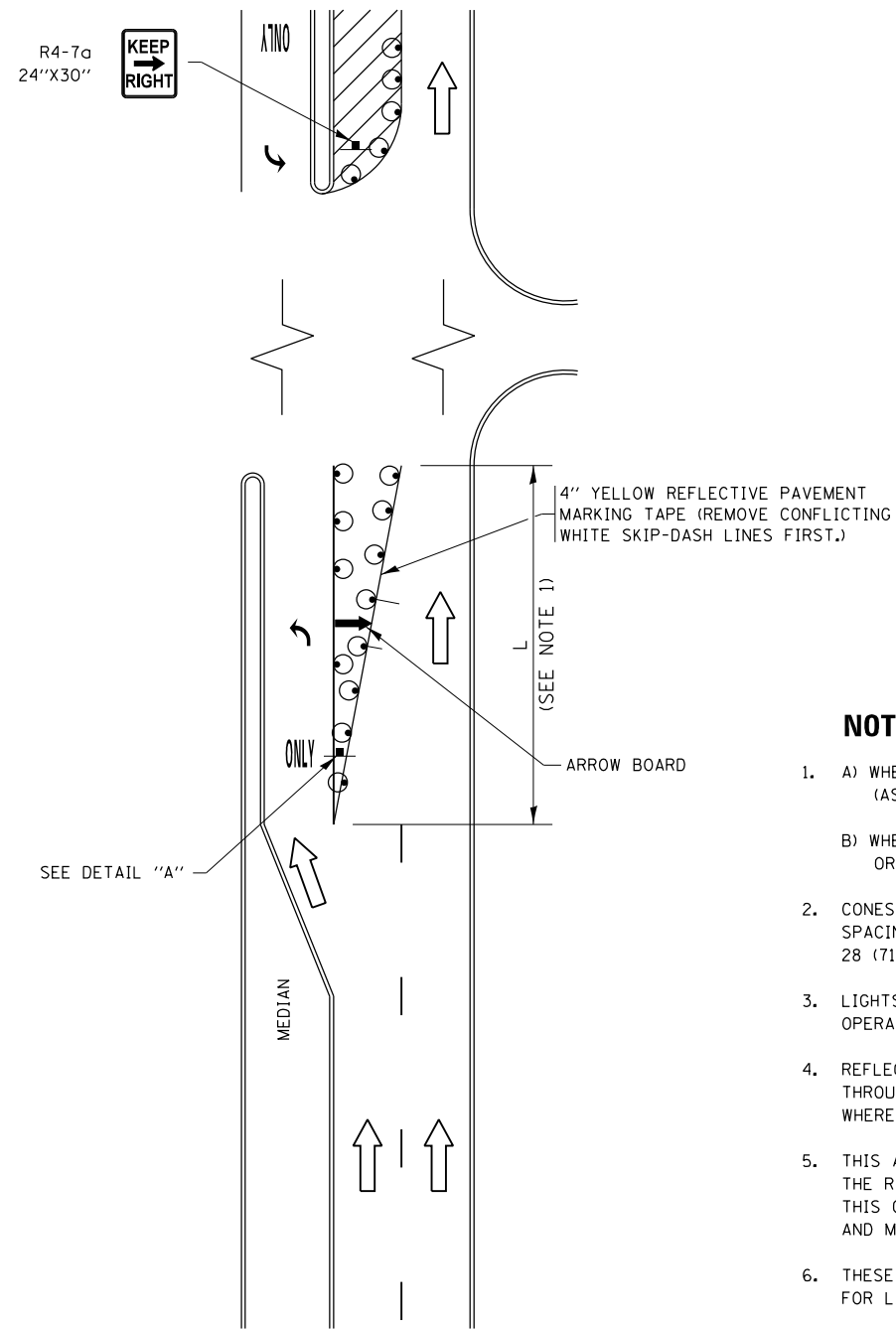

FIGURE 1

TURN BAY ENTRANCE WITHIN A LANE CLOSURE

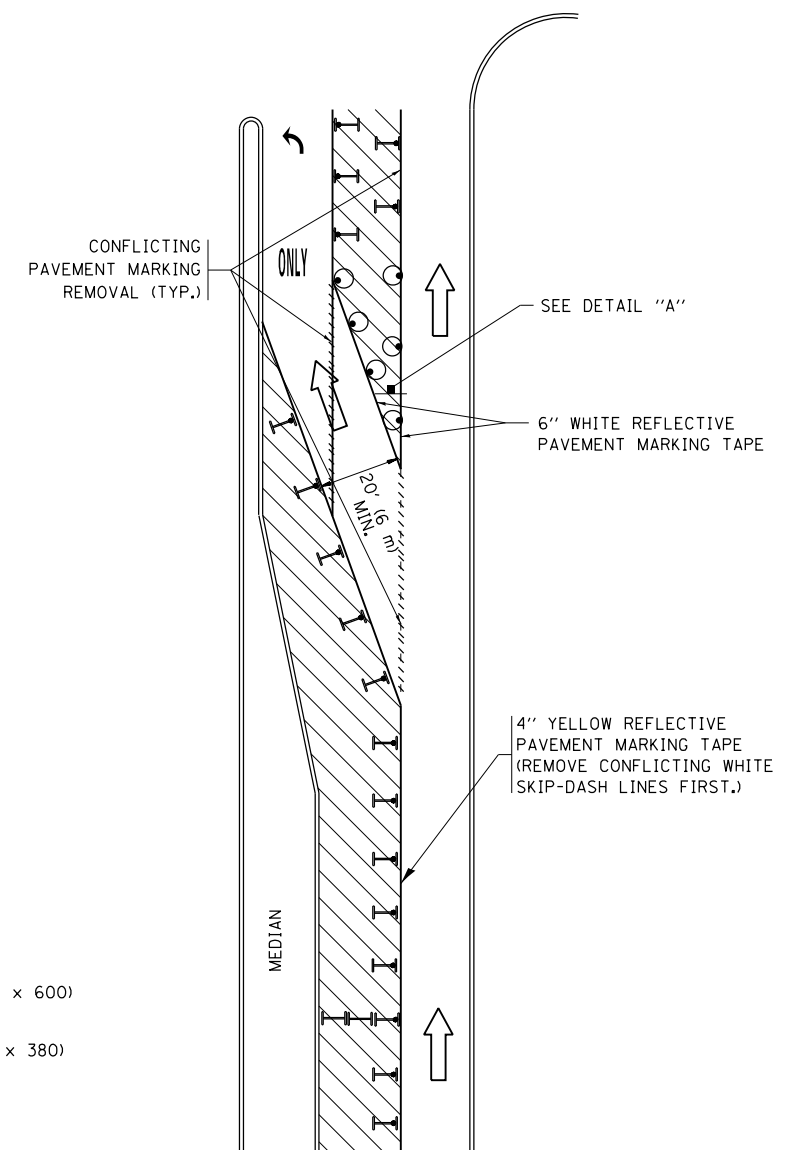
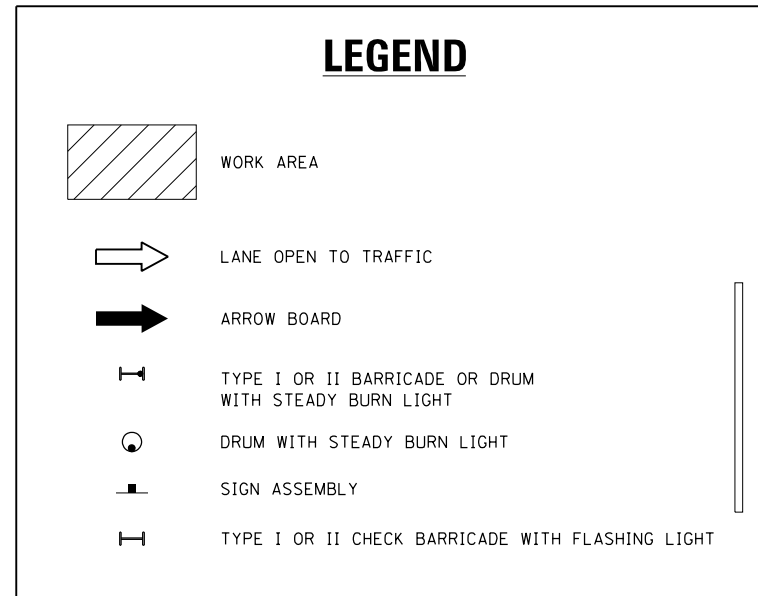
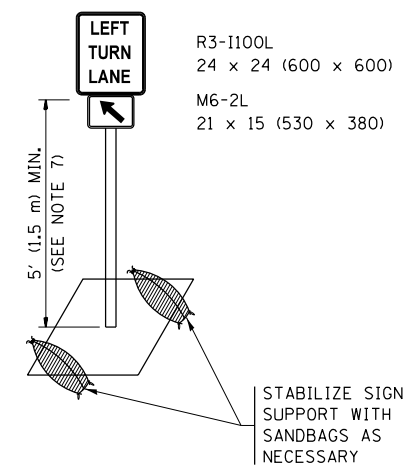

FIGURE 2



NOTES:

1. A) WHEN "L" IS \leq THE STORAGE LENGTH OF THE TURN LANE (AS SHOWN IN FIG. 1), USE FIGURE 1.
B) WHEN "L" IS $>$ THE STORAGE LENGTH OF THE TURN LANE OR THE TURN LANE IS WITHIN THE LANE CLOSURE, USE FIGURE 2.
2. CONES MAY BE SUBSTITUTED FOR BARRICADES OR DRUMS AT HALF THE SPACING DURING DAY OPERATIONS. CONES SHALL BE A MINIMUM OF 28 (710) IN HEIGHT.
3. LIGHTS WILL NOT BE REQUIRED ON BARRICADES OR DRUMS FOR DAY OPERATIONS. ALL LIGHTS SHALL BE MONODIRECTIONAL.
4. REFLECTIVE TEMPORARY PAVEMENT MARKINGS SHALL BE PLACED THROUGHOUT THE BARRICADED AREAS OF EACH TURN BAY AS SHOWN WHERE THE CLOSURE TIME IS GREATER THAN FOURTEEN (14) DAYS.
5. THIS APPLICATION ALSO APPLIES WHEN WORK IS BEING PERFORMED IN THE RIGHT LANE(S) AND THE RIGHT TURN BAY IS TO REMAIN OPEN. UNDER THIS CONDITION, "RIGHT TURN LANE" R3-1100R 24 x 24 (600 x 600) AND M6-2R 21 x 15 (530 x 380) SHALL BE USED.
6. THESE CONTROLS SHALL SUPPLEMENT MAINLINE TRAFFIC CONTROL FOR LANE CLOSURES.
7. THE SIGNS SHALL BE MOUNTED ABOVE THE BARRICADES/DRUMS ON SEPARATE SIGN SUPPORTS THAT MEET NCHRP 350 OR MASH PREQUIREMENTS.
8. TRAFFIC CONTROL AND PROTECTION AT TURN BAYS (TO REMAIN OPEN TO TRAFFIC) SHALL BE INCLUDED IN THE COST OF SPECIFIED TRAFFIC CONTROL STANDARDS OR ITEMS.



DETAIL A

All dimensions are in inches (millimeters) unless otherwise shown.

FILE NAME =	USER NAME = guillaumefp	REVISED - T. RAMMACHER 09-08-94	REVISED - R. BORO 09-14-09	STATE OF ILLINOIS DEPARTMENT OF TRANSPORTATION	TRAFFIC CONTROL AND PROTECTION AT TURN BAYS (TO REMAIN OPEN TO TRAFFIC)			F.A.P. R.T.E.	SECTION	COUNTY	TOTAL SHEETS	SHEET NO.
Default		REVISED - A. HOUSEH 11-07-95	REVISED - A. SCHUETZE 07-01-13					541	2016-022RS	LAKE	20	17
	PLOT SCALE = 100.0000' / in.	REVISED - A. HOUSEH 10-12-96	REVISED - A. SCHUETZE 09-15-16		TC-14			CONTRACT NO. 62C73				
	PLOT DATE = 3/24/2017	REVISED - T. RAMMACHER 01-06-00	REVISED -		ILLINOIS FED. AID PROJECT							

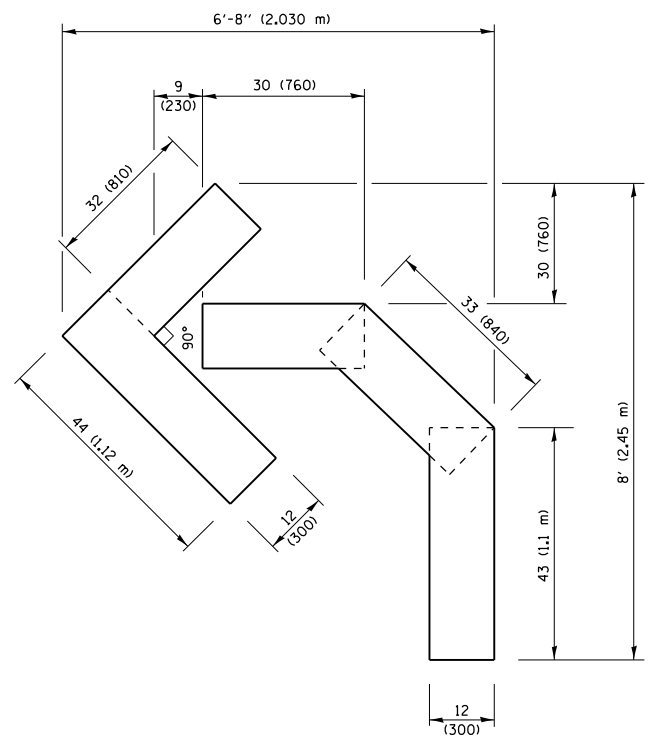

QUANTITY
 4 (100) LINE = 45.5 ft. (13.9 m)
 15.2 sq. ft. (1.41 sq. m)

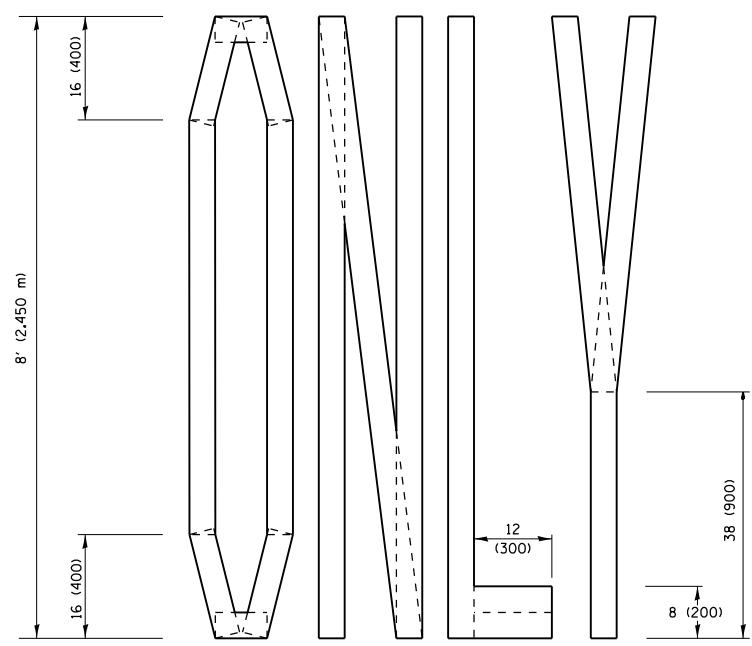
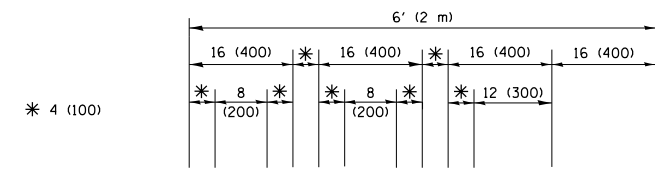

QUANTITY
 4 (100) LINE = 64.1 ft. (19.5 m)
 21.4 sq. ft. (1.99 sq. m)

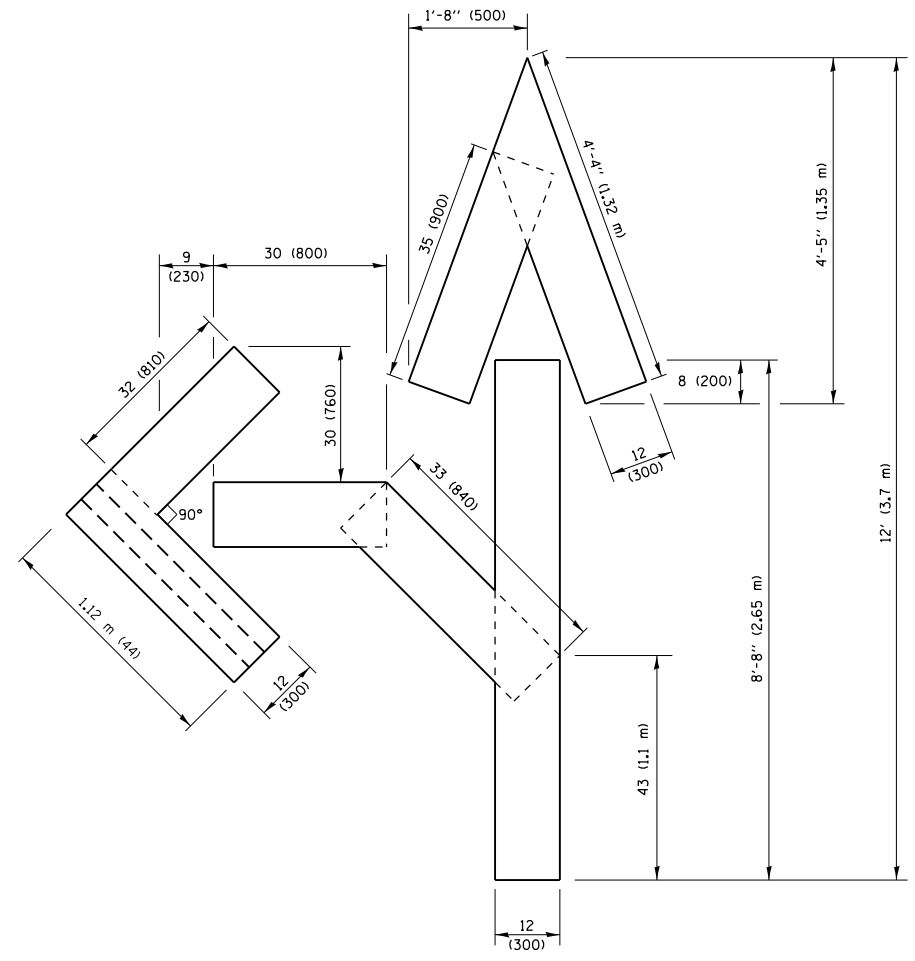

QUANTITY
 4 (100) LINE = 82.5 ft. (25.1 m)
 27.5 sq. ft. (2.53 sq. m)

NOTE:
 ALL QUANTITIES OF PLACEMENT ARE REPRESENTED IN LINEAR FEET OF 4" LINES TO MATCH THE 4" TEMPORARY TAPE PAY ITEM AND REPRESENTS THE TOTAL QUANTITY OF 4" TAPE REQUIRED.

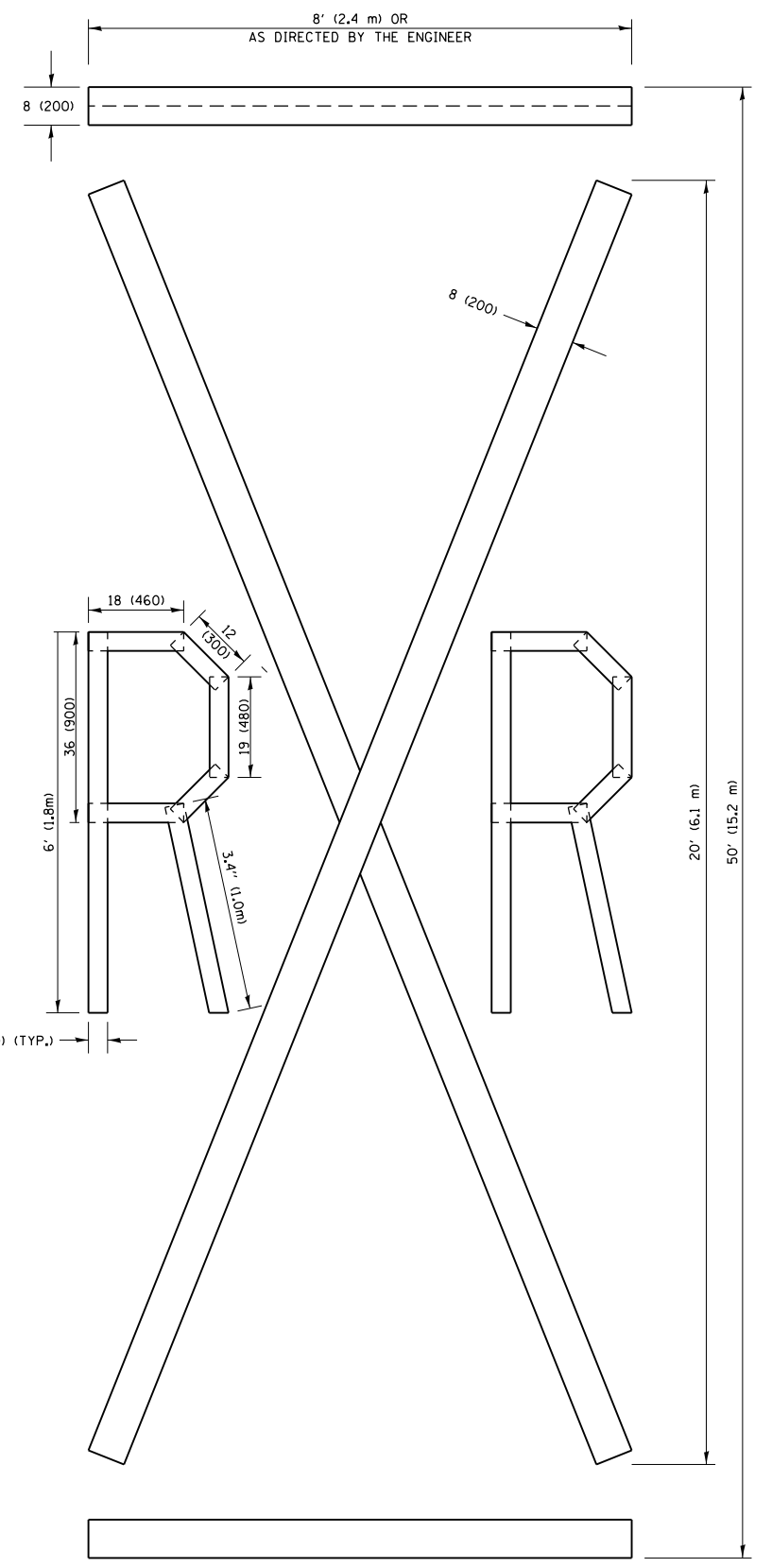

QUANTITY
 4 (100) LINE = 225.9 ft. (68.9 m)
 75.3 sq. ft. (6.99 sq. m)

All dimensions are in inches (millimeters) unless otherwise shown.

FILE NAME =	USER NAME = guilleumefp	DESIGNED -	REVISED - T. RAMMACHER 03-02-98
pw:\1\084EBIDINTEG\illinois.gov\PIWIDOT\Documents\IDOT Offices\District 1\Projects\01389\BROWNS\Notes\Design\Diststd.dgn		CHECKED -	REVISED - E. GOMEZ 08-28-00
		DATE - 09-18-94	REVISED - E. GOMEZ 08-28-00
			REVISED - A. SCHUETZE 09-15-16

**STATE OF ILLINOIS
 DEPARTMENT OF TRANSPORTATION**

SHORT TERM PAVEMENT MARKING LETTERS AND SYMBOLS			
SCALE: NONE	SHEET NO. 1 OF 1 SHEETS	STA.	TO STA.

F.A.P. RTE.	SECTION	COUNTY	TOTAL SHEETS	SHEET NO.
541	2016-022RS	LAKE	20	18
TC-16		CONTRACT NO. 62C73		
FED. ROAD DIST. NO. 1 ILLINOIS FED. AID PROJECT				

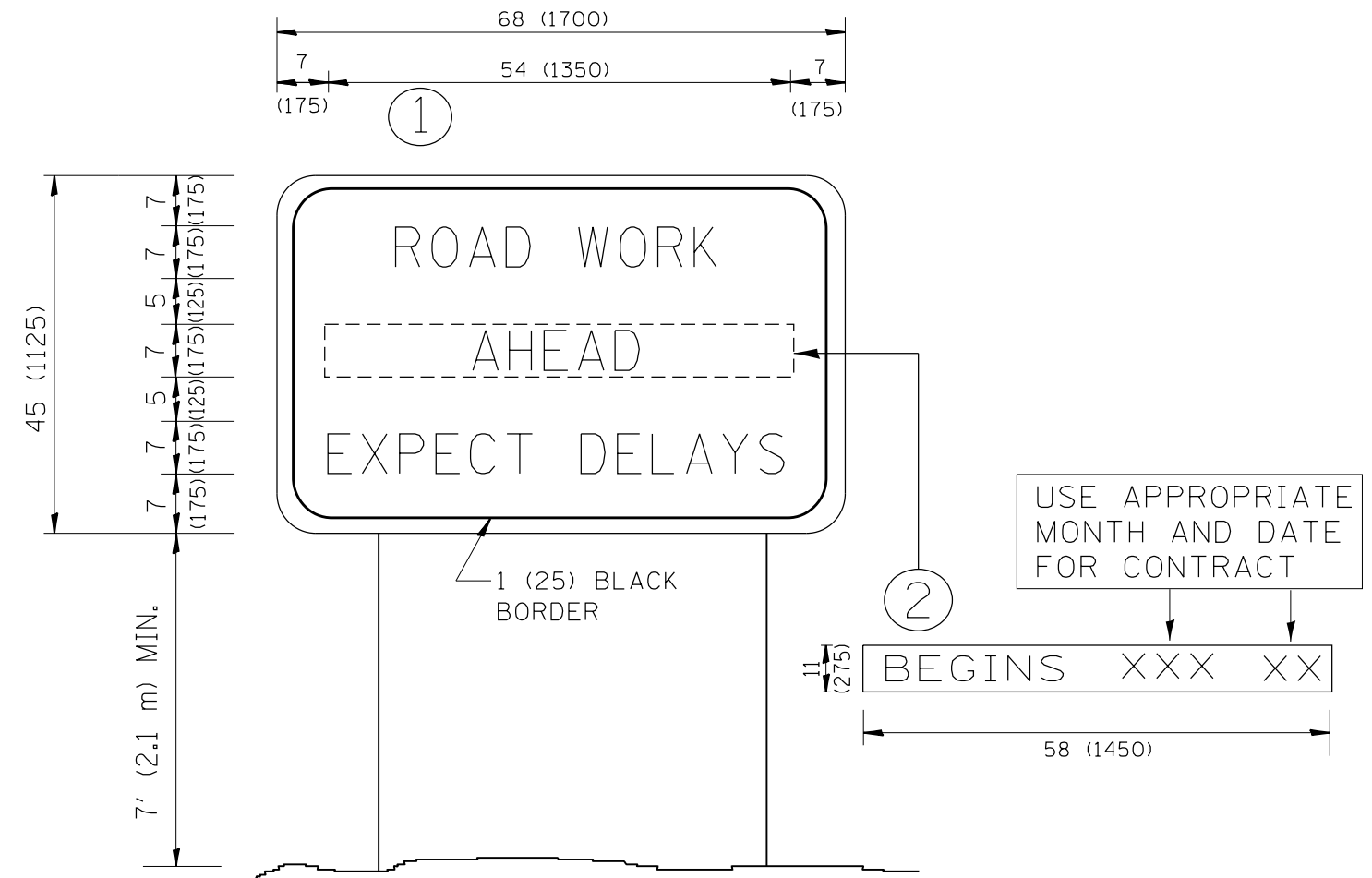

NOTES:

1. USE BLACK LETTERING ON ORANGE BACKGROUND.
2. ERECT SIGNS IN ADVANCE OF THE LOCATION FOR THE "ROAD CONSTRUCTION AHEAD" SIGN AT LOCATIONS AS DIRECTED BY THE ENGINEER.
3. ERECT SIGN ① WITH INSTALLED PANEL ② ONE WEEK PRIOR TO THE START OF CONSTRUCTION.
4. REMOVE PANEL ② SOON AFTER THE START OF CONSTRUCTION.
5. SEE SPECIAL PROVISION FOR "TEMPORARY INFORMATION SIGNING" FOR ADDITIONAL INFORMATION.
6. ONE SIGN ASSEMBLY EQUALS 25.70 SQ. FT. (2.3 SQ. M.)
7. SHALL BE PAID FOR AS TEMPORARY INFORMATION SIGNING.

ALL DIMENSIONS ARE IN INCHES (MILLIMETERS) UNLESS OTHERWISE SHOWN.

FILE NAME =	USER NAME = guillaumejp	DESIGNED -	REVISED - R. MIRS 09-15-97
p:\11\084EBIDINTEG\illinois.gov\PIDOT\Documents\DOT Offices\District 1\Projects\DI380\Drawings\Design\Diststd.dgn		CHECKED -	REVISED - R. MIRS 12-11-97
		PLOT SCALE = 100.0000' / in.	REVISED - T. RAMMACHER 02-02-99
		DATE -	REVISED - C. JUCIUS 01-31-07

**STATE OF ILLINOIS
DEPARTMENT OF TRANSPORTATION**

**ARTERIAL ROAD
INFORMATION SIGN**

SCALE: NONE SHEET NO. 1 OF 1 SHEETS STA. TO STA.

F.A.P. RTE.	SECTION	COUNTY	TOTAL SHEETS	SHEET NO.
541	2016-022RS	LAKE	20	19
TC-22			CONTRACT NO. 62C73	
FED. ROAD DIST. NO. 1 ILLINOIS FED. AID PROJECT				

LOOPS NEXT TO SHOULDERS

PROVIDE A PAVEMENT REPLACEMENT NOTE WHICH SHOULD EQUAL 3' (900 mm) X WIDTH OF PAVED SHOULDER.

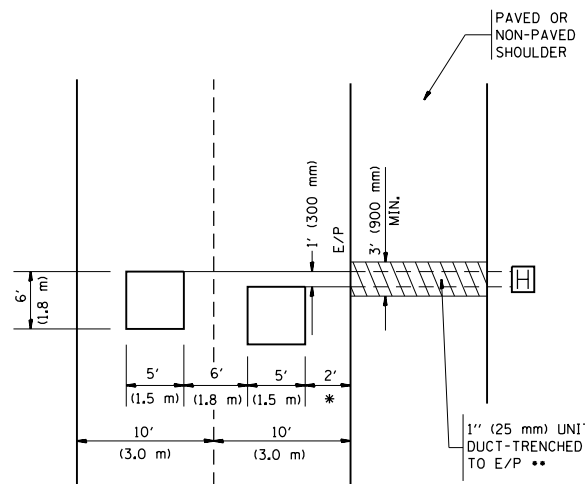

* = (600 mm)

** UNIT DUCT IS TO BE SHOWN ON PLAN SHEETS BUT SHALL NOT BE INCLUDED IN THE PAY ITEMS.

LEFT TURN LANES WITH MEDIANS
VOLUME DENSITY ("FAR OUT" DETECTION)
ON SAME APPROACH

(PROTECTED / PERMITTED LEFT TURN PHASING)

HANDHOLE LOCATION MAY VARY DEPENDING ON GEOMETRICS AND DESIGN OF TRAFFIC SIGNALS. HEAVY-DUTY HANDHOLES TO BE USED WHEN THE MEDIAN IS MOUNTABLE. REFER TO STANDARD 814001 TO ENSURE THAT HANDHOLE FITS IN MEDIAN.

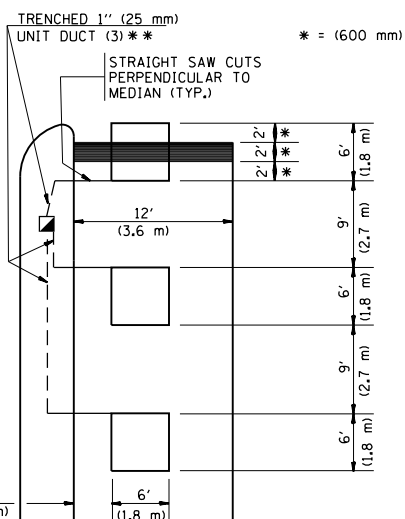

** UNIT DUCT IS TO BE SHOWN ON PLAN SHEETS BUT SHALL NOT BE INCLUDED IN THE PAY ITEMS.

NOTE: DUAL LEFT TURNS NOT SHOWN REFER TO PLAN SHEET FOR DETECTOR LOOP REPLACEMENT

LEFT TURN LANES WITHOUT MEDIANS
VOLUME DENSITY ("FAR OUT" DETECTION)
ON SAME APPROACH

(PROTECTED / PERMITTED LEFT TURN PHASING)

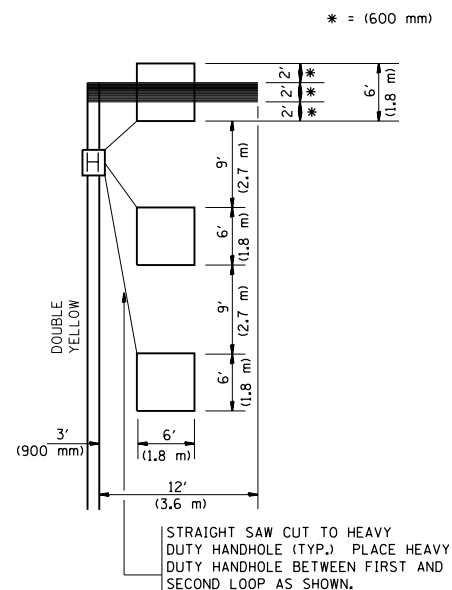

NOTE: DUAL LEFT TURNS NOT SHOWN REFER TO PLAN SHEET FOR DETECTOR LOOP REPLACEMENT

ARTERIAL-VOLUME DENSITY ("FAR OUT" DETECTION)
CROSS STREET-VOLUME DENSITY ("FAR OUT" DETECTION)

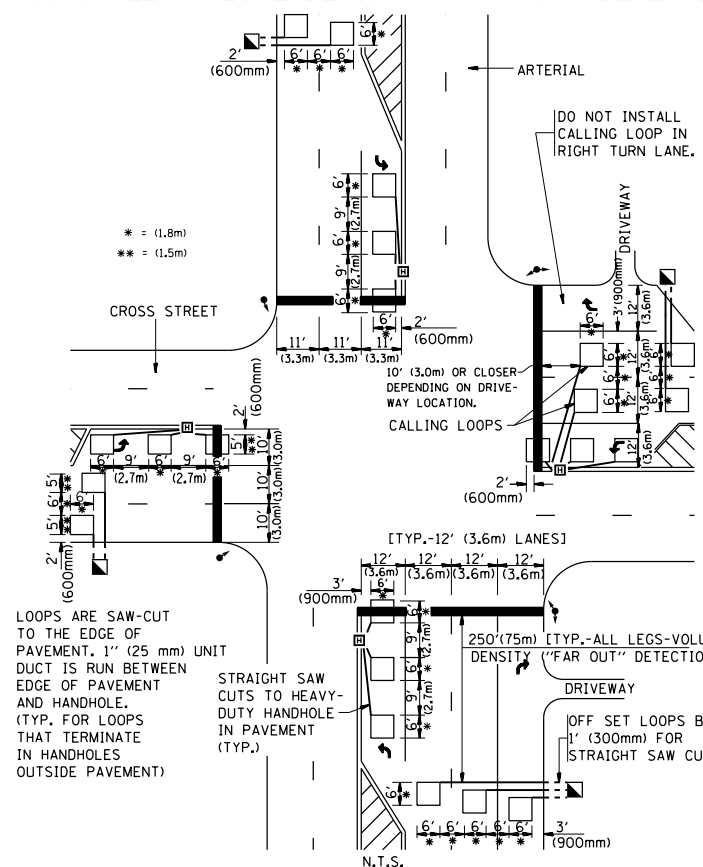

DETAIL 1
N.T.S.

ARTERIAL-VOLUME DENSITY ("FAR OUT" DETECTION)
CROSS STREET-NON VOLUME DENSITY ("UPTIGHT" PRESENCE DETECTION)

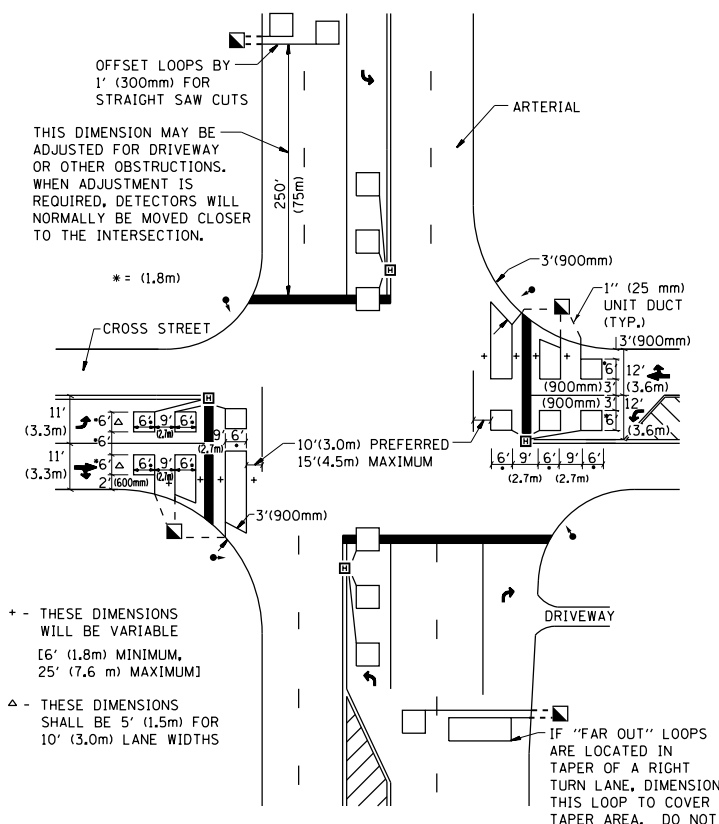

DETAIL 2
N.T.S.

NOTES:

VEHICLES LOOP DETECTORS

- * ALL LEAD IN CABLE SHALL BE TWO CONDUCTOR NO. 14 TWISTED, SHIELDED.
- * EACH DETECTOR LOOP SHALL HAVE ITS OWN SAW CUT FROM THE LOOP TO THE EDGE OF PAVEMENT OR TO A HANDHOLE IN THE PAVEMENT.
- * EACH DETECTOR LOOP SHALL HAVE ITS OWN ONE INCH (25 mm) UNIT DUCT BETWEEN THE EDGE OF PAVEMENT AND THE FIRST HANDHOLE OR JUNCTION BOX. EACH UNIT DUCT RUN SHALL BE SHOWN ON THE PLANS BY THE DESIGNER, BUT SHALL NOT BE PAID FOR SEPARATELY. THIS ITEM IS INCIDENTAL TO THE PAY ITEM FOR DETECTOR LOOPS.
- * ONE DIMENSION OF ALL DETECTOR LOOPS SHALL BE SIX FEET (1.8 m)
- * EACH LANE OF NON-LOCKING, PRESENCE DETECTION AND EACH LANE OF A DOUBLE LEFT TURN LANE REQUIRES A SEPARATE INDUCTIVE LOOP DETECTOR AND LEAD IN CABLE.
- * WHEN NON-LOCKING, PRESENCE DETECTION IS USED, MORE THAN ONE LOOP PER LANE IS REQUIRED BEHIND THE STOP BAR (i.e. 1-1/2, 1-3/4, 2).
- * WHEN SYSTEM LOOPS ARE REQUIRED ON AN APPROACH OF AN INTERSECTION, THE LOOPS USED FOR VOLUME DENSITY AND INTERSECTION TIMING SHALL ALSO BE USED AS SYSTEM DETECTORS. EACH ONE OF THESE TYPE OF LOOPS REQUIRES A SEPARATE TWO CONDUCTOR NO. 14 TWISTED SHIELDED CABLE AND A SEPARATE INDUCTIVE LOOP DETECTOR WHEN NEW CONTROLLERS ARE UTILIZED. THE DESIGNER SHALL LABEL THESE TYPES OF LOOPS AS "INTERSECTION AND SAMPLING (SYSTEM) DETECTORS" ON THE SIGNAL LAYOUT, THE INTERCONNECT PLAN AND THE SYSTEM CABLE PLAN. WHEN AN EXISTING CONTROLLER IS UTILIZED FOR THIS TYPE OF DETECTION, THE PAY ITEM "INDUCTIVE LOOP DETECTOR WITH SYSTEM OUTPUT" SHOULD BE USED.

PLACEMENT OF DETECTORS

THE FOLLOWING FIGURES REPRESENT THE MOST COMMON DETECTOR LOOP LOCATIONS AND SIZES. ADJUSTMENTS WILL BE NECESSARY FOR SPECIFIC GEOMETRIC CONSIDERATIONS.

LOCATIONS AND DEMENSIONS OF DETECTOR LOOPS ARE REQUIRED ON ALL SIGNAL LAYOUT PLAN SHEETS.

"FAR OUT" DETECTION REFERS TO LOCKING, PRESENCE TYPE DETECTION LOCATED IN THRU LANES, RIGHT TURN LANES, AND RIGHT TURN LANE TAPER AREAS (IF APPLICABLE), USUALLY 250' (75 m) IN ADVANCE OF STOP BARS. "UPTIGHT" DETECTION REFERS TO NON-LOCKING PRESENCE TYPE DETECTION LOCATED IN ALL LANES AND 10'-15' (3.0 m-4.5 m) BEHIND THE CROSSING STREET'S EDGE OF PAVEMENT EXTENDED.

NOTE:

ALL DETAILS AND NOTES SHOWN ARE FROM THE I.D.O.T. DISTRICT 1 TRAFFIC SIGNAL DESIGN GUIDELINES DATED JANUARY 1995

THIS DRAWING HAS BEEN PREPARED TO ASSIST THE RESIDENT ENGINEER FOR ALL ROADWAY RESURFACING OR S.M.A.R.T. PROJECTS WHERE THE DIMENSIONS ARE NOT SHOWN ON THE PLANS AND THE FINAL LOCATIONS FOR CROSSWALKS OR STOP BARS ARE NOT DETERMINED.

FILE NAME =	USER NAME = guillaumejp	DESIGNED -	REVISED -	STATE OF ILLINOIS DEPARTMENT OF TRANSPORTATION	DISTRICT 1 - DETECTOR LOOP INSTALLATION DETAILS FOR ROADWAY RESURFACING			F.A.P. RTE.	SECTION	COUNTY	TOTAL SHEETS	SHEET NO.
p:\11\084EBIDINTEG\illinois.gov\PIW001\Documents\IDOT Offices\District 1\Projects\DI380\Drawings\Design\Diststd.dgn		CHECKED - R.K.F.	REVISED -		541	2016-022RS	LAKE	20	20			
PLOT SCALE = 100.0000' / in.		DATE -	REVISED -		TS-07			CONTRACT NO. 62C73				
PLOT DATE = 3/24/2017					SCALE: NONE	SHEET NO. 1 OF 1 SHEETS	STA. TO STA.	FED. ROAD DIST. NO. 1 ILLINOIS FED. AID PROJECT				