

STATE OF ILLINOIS
DEPARTMENT OF TRANSPORTATION

FAP	SECTION	COUNTY	DATE	SHEET	SHEET NO. 3
337	20R-5	LAKE	562	224	3 SHEETS
FED. ROAD DIST. NO. 7		ILLINOIS		FED. AID PROJECT-	
D-91-552-99		Contract No. 60881			

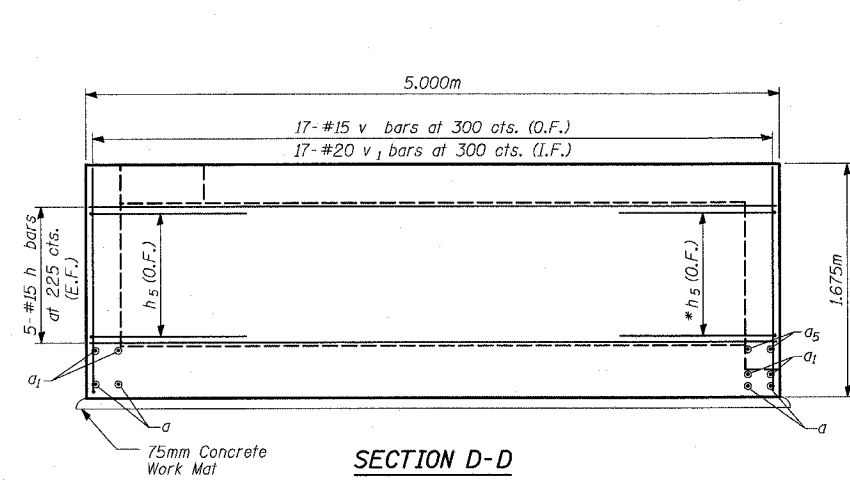

SECTION D-D

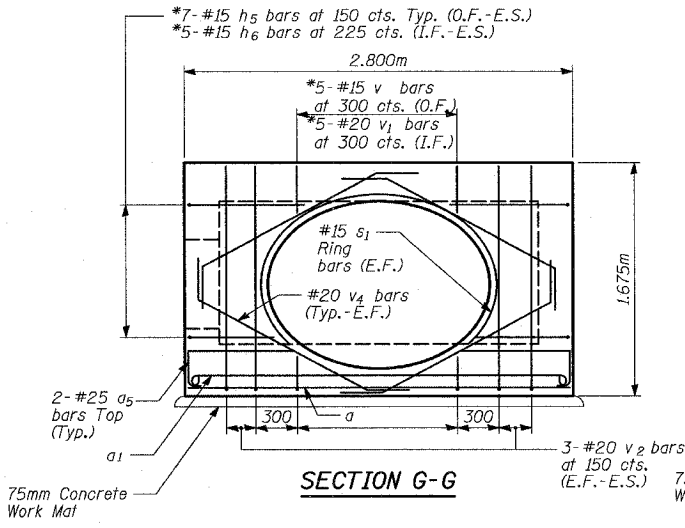

SECTION G-G

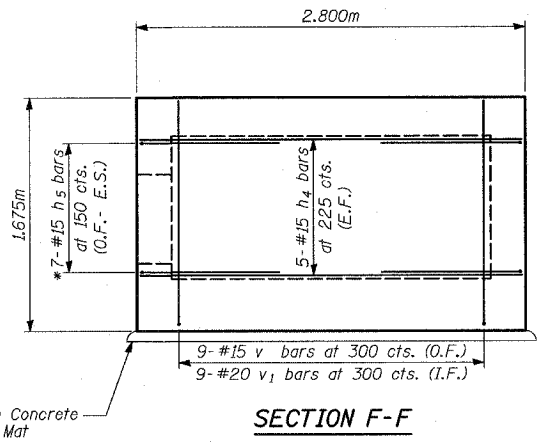

SECTION F-F

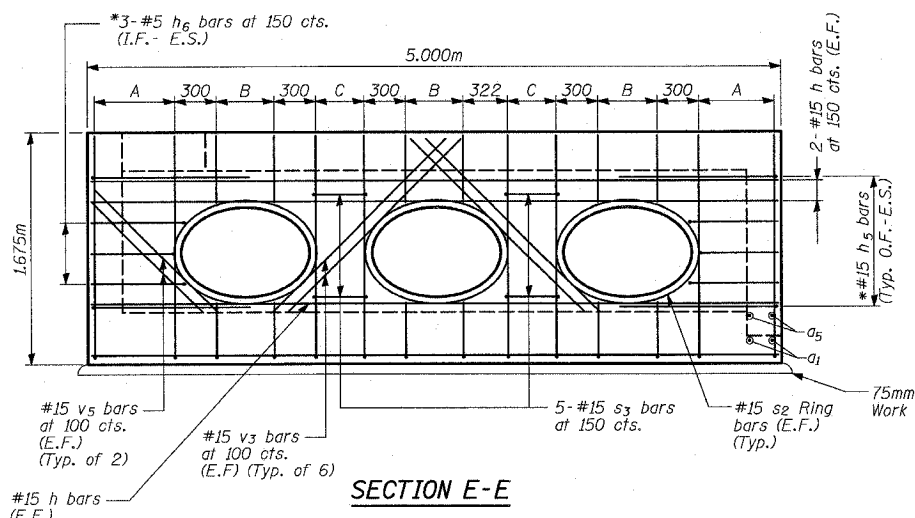

SECTION E-E

A	4-#20 v2 bars at 200 cts. (E.F.)
B	*3-#15 v bars at 300 cts. (O.F.)
C	*3-#20 v1 bars at 300 cts. (I.F.)
	3-#20 v2 bars at 150 cts. (E.F.)

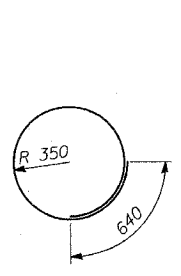

BAR s

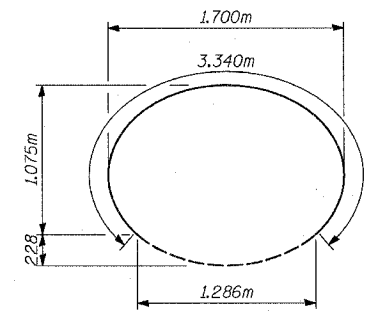

BAR s1

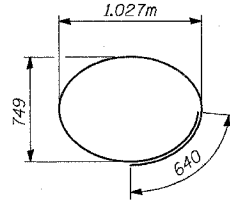

BAR s2

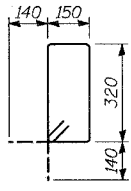

BAR s3

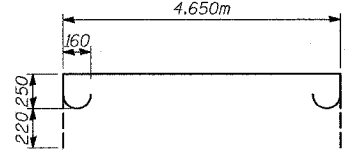

BAR h2

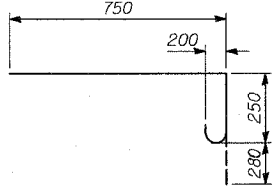

BAR a5

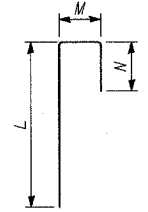

BARS h3 & h6

Bar	L	M	N
h3	860	160	200
h6	950	120	180

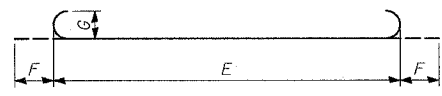

BARS a1 & h1

Bar	E	F	G
a1	2.700m	280	200
h1	4.900m	220	160

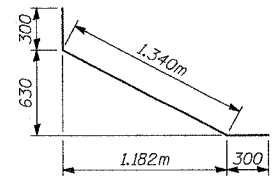

BAR v4

BILL OF MATERIAL

Bar	No.	Size	Length (m)	Shape
a	33	#15	2.70	U
a1	48	#25	3.26	U
a2	3	#25	2.70	U
a3	12	#15	1.50	U
a4	4	#15	0.71	U
a5	4	#25	1.28	U
h	34	#15	4.90	U
h1	21	#20	5.34	U
h2	4	#20	5.59	U
h3	4	#20	1.22	U
h4	10	#15	2.70	U
h5	28	#15	1.80	U
h6	16	#15	1.25	U
h7	3	#20	4.90	U
s	2	#15	2.84	U
s1	2	#15	3.34	U
s2	6	#15	3.45	U
s3	10	#15	1.22	U
v	40	#15	2.19	U
v1	40	#20	1.87	U
v2	40	#20	2.34	U
v3	24	#15	1.77	U
v4	8	#20	1.94	U
v5	8	#15	1.26	U
Concrete Structures			CU M	13
Reinforcement Bars			KG	2,350

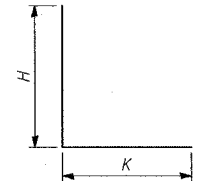

BARS h5, v, v1, v2

Bar	H	K
h5	900	900
v	1.550m	640
v1	1.550m	320
v2	1.550m	790

TYLIN INTERNATIONAL

DESIGNED	MI, MAF
CHECKED	TD
DRAWN	DJR
CHECKED	TD
DATE	03-22-2004

NOTES:
Reinforcement bar clearance to be 50mm unless otherwise noted.
E.F. - denotes Each Face
E.S. - denotes Each Side
I.F. - denotes Inside Face
O.F. - denotes Outside Face
* Cut bars to fit in field

DETAILS 2

JUNCTION CHAMBER 4
STA. 104+013.220
IL ROUTE 22
FAP 337 SECTION 20R-5
IL RTE 83 TO US 45/IL 21
LAKE COUNTY