

PANEL SIGN DESIGN TYPE 1

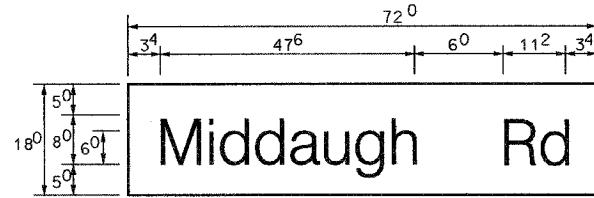

9.0 Sq. Ft. each  
 2 Required  
 Design Series D

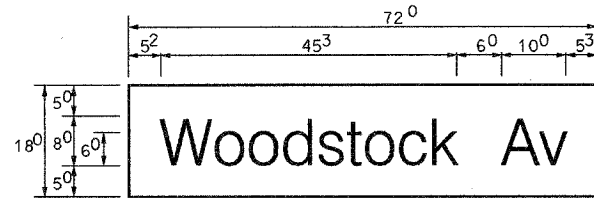

9.0 Sq. Ft. each  
 2 Required  
 Design Series C

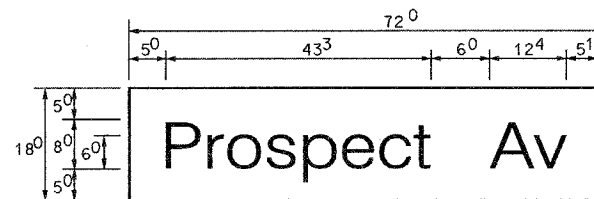

9.0 Sq. Ft. each  
 2 Required  
 Design Series D

NOTE: SIGN DIMENSIONS ARE IN ENGLISH UNITS

SUPPORTING CHANNELS

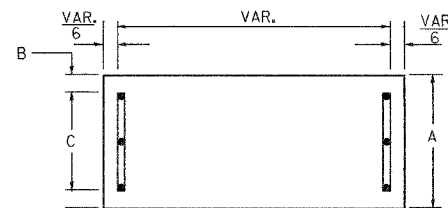

A	B	C
18"	2"	14"

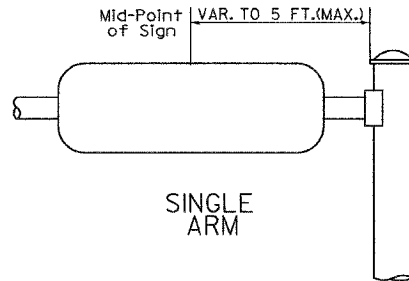

SUPPORTING CHANNELS

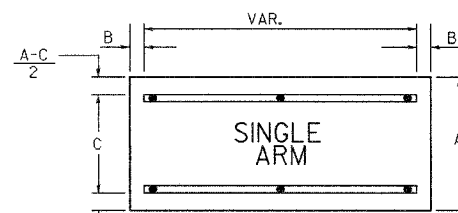

A	B	C
18"	2"	12"
30"	2"	22"

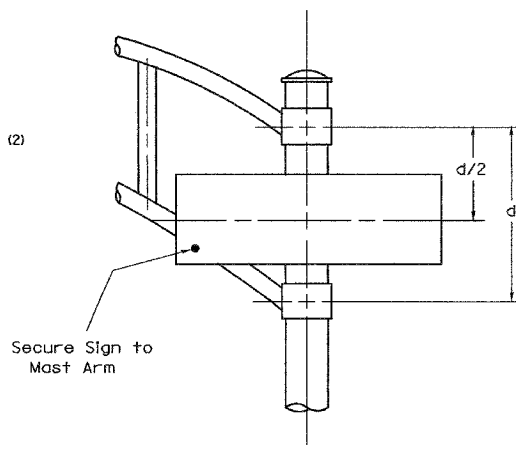

DUAL ARM  
 SIGNFIX ALUMINUM CHANNEL FRAMING SYSTEM  
 Shall be used. See Note #5.

Upper Case To Lower Case  
 Spacing Chart 8-6 Inch Series 'C & D'

EXAMPLE, 2 DENOTES 3/8

FIRST LETTER	SECOND LETTER																	
	a c d e		g o q		b h i k l		m n p r u		f w		j		s t		v y		x z	
	C	D	C	D	C	D	C	D	C	D	C	D	C	D	C	D	C	D
A W X	12	14	14	15	12	14	06	10	11	14	06	10	11	12	12	14	14	15
B	14	15	20	21	14	15	11	12	14	15	12	14	12	14	14	16	17	17
C E G	14	15	20	21	12	14	06	10	12	14	12	14	14	15	14	15	15	15
D O Q R	14	15	20	21	14	15	06	10	12	14	12	14	14	15	14	15	14	15
F	05	06	14	15	06	10	05	06	06	10	06	10	06	10	11	12	12	12
H I M N	20	21	22	24	20	21	14	15	16	17	16	17	20	21	20	21	20	21
J U	20	21	20	21	16	17	14	15	16	17	16	17	16	17	20	21	20	21
K L	11	12	16	17	11	12	05	06	11	12	11	12	11	12	12	14	12	14
P	12	14	14	15	12	14	05	06	11	12	11	12	12	14	12	14	12	14
S	12	14	16	17	12	14	06	10	12	14	12	14	12	14	12	14	12	14
T	11	12	16	17	06	10	06	10	11	12	11	12	11	12	12	14	12	14
V	06	10	14	15	11	12	06	10	12	14	12	14	12	14	12	14	12	14
Y	05	06	14	15	06	10	05	06	05	07	05	06	06	10	11	12	11	12
Z	16	17	22	24	16	17	12	14	16	17	16	17	16	17	20	21	20	21

Lower Case To Lower Case  
 Spacing Chart 6 Inch Series 'C & D'

FIRST LETTER	SECOND LETTER																	
	a c d e		g o q		b h i k l		m n p r u		f w		j		s t		v y		x z	
	C	D	C	D	C	D	C	D	C	D	C	D	C	D	C	D	C	D
ad h g i j	16	17	22	24	16	17	12	14	14	15	14	15	16	17	16	17	16	17
l m n q u																		
bf k o p s	12	14	16	17	11	12	05	06	11	12	11	12	12	14	12	14	12	14
c e	12	14	16	17	12	14	06	10	12	14	12	14	12	14	12	14	12	14
r	06	10	12	14	06	10	03	03	05	06	05	06	06	10	06	10	06	10
t z	12	14	16	17	12	14	06	10	11	12	11	12	12	14	12	14	12	14
v y	11	12	14	15	11	12	05	06	06	10	06	10	11	12	11	12	11	12
w	11	12	14	15	11	12	05	06	11	12	11	12	11	12	12	14	12	14
x	12	14	16	17	11	12	05	06	11	12	11	12	11	12	12	14	12	14

Number To Number  
 Spacing Chart 8 Inch Series 'C & D'

FIRST NUMBER	SECOND NUMBER																			
	0		1		2		3		4		5		6		7		8		9	
	C	D	C	D	C	D	C	D	C	D	C	D	C	D	C	D	C	D	C	D
0 9	16	17	16	17	14	15	12	14	14	15	14	15	16	17	12	14	16	17	16	17
1	20	21	20	21	20	21	16	17	14	15	20	21	20	21	14	15	20	21	20	21
2 3 4	14	15	14	15	14	15	12	14	14	15	14	15	14	15	11	12	16	17	14	15
5	14	15	14	15	14	15	11	12	11	12	14	15	14	15	11	12	14	15	14	15
6	16	17	14	15	14	15	12	15	12	14	14	15	14	15	11	12	14	15	14	15
7	12	14	12	14	14	15	12	15	05	06	2	14	14	15	11	12	14	15	12	14
8	16	17	16	17	14	15	12	15	12	14	14	15	16	17	12	14	16	17	14	15

UPPER AND LOWER CASE LETTER WIDTHS

LETTERS	6 INCH UPPER CASE LETTERS		8 INCH UPPER CASE LETTERS		LETTERS	6 INCH LOWER CASE LETTERS	
	C	D	C	D		C	D
A	3 5/8	5 0	5 0	6 5/8	a	3 5/8	4 2
B	3 2	4 0	4 3	5 3	b	3 5/8	4 2
C	3 2	4 0	4 3	5 3	c	3 5/8	4 1
D	3 2	4 0	4 3	5 3	d	3 5/8	4 2
E	3 0	3 5/8	4 0	4 7	e	3 5/8	4 2
F	3 0	3 5/8	4 0	4 7	f	2 3	2 6
G	3 2	4 0	4 3	5 3	g	3 5/8	4 2
H	3 2	4 0	4 3	5 3	h	3 5/8	4 2
I	0 7	0 7	1 1	1 2	i	1 1	1 1
J	3 0	3 6	4 0	5 0	j	2 0	2 2
K	3 2	4 1	4 3	5 4	k	3 5/8	4 2
L	3 0	3 5/8	4 0	4 7	l	1 1	1 1
M	3 7	4 5	5 1	6 1	m	6 0	7 0
N	3 2	4 0	4 3	5 3	n	3 5/8	4 2
O	3 4	4 2	4 5	5 5	o	3 6	4 3
P	3 2	4 0	4 3	5 3	p	3 5/8	4 2
Q	3 4	4 2	4 5	5 5	q	3 5/8	4 2
R	3 2	4 0	4 3	5 3	r	2 6	3 2
S	3 2	4 0	4 3	5 3	s	3 6	4 2
T	3 0	3 5/8	4 0	4 7	t	2 7	3 2
U	3 2	4 0	4 3	5 3	u	3 5/8	4 2
V	3 5/8	4 4	4 7	6 0	v	4 2	4 7
W	4 4	5 2	6 0	7 0	w	5 5	6 4
X	3 4	4 0	4 5	5 3	x	4 4	5 1
Y	3 6	5 0	5 0	6 6	y	4 6	5 3
Z	3 2	4 0	4 3	5 3	z	3 6	4 3

NUMBER TO NUMBER

NUMBER	6 INCH SERIES		8 INCH SERIES	
	C	D	C	D
1	1 2	1 4	1 5	2 0
2	3 2	4 0	4 3	5 3
3	3 2	4 0	4 3	5 3
4	3 5	4 3	4 7	5 7
5	3 2	4 0	4 3	5 3
6	3 2	4 0	4 3	5 3
7	3 2	4 0	4 3	5 3
8	3 2	4 0	4 3	5 3
9	3 2	4 0	4 3	5 3
0	3 4	4 2	4 5	5 5

REVISIONS

NAME	DATE
D.A.Z./D.A.G.	11/90
CADD	6/98
	10/00

Illinois Department of Transportation  
 DISTRICT I

## MAST ARM MOUNTED STREET NAME SIGNS

SCALE: NONE  
 DATE: \*\*DATE\*\*

DRAWN BY: ROB  
 DESIGNED BY: JHE  
 CHECKED BY: DAD

- GENERAL NOTES
- WHERE MAST ARM MOUNTED STREET NAME SIGNS ARE SPECIFIED, THE MAST ARM ASSEMBLY AND POLES SHALL BE DESIGNED TO SUPPORT THE LOADINGS CALLED FOR ON STANDARDS 834001, 834006 AND 834011, AS APPLICABLE, PLUS TWO (2) SIGN PANELS 2'-6" X 6'-0" MOUNTED AS SHOWN. THE DESIGN SHALL BE IN ACCORDANCE WITH THE REQUIREMENTS OF THE CURRENT STANDARD SPECIFICATIONS FOR STRUCTURAL SUPPORTS FOR HIGHWAY SIGNS, LUMINAIRES, AND TRAFFIC SIGNALS AS PUBLISHED BY THE AMERICAN ASSOCIATION OF STATE HIGHWAY AND TRANSPORTATION OFFICIALS FOR 80 M.P.H. WIND VELOCITY.
  - ALL SIGNS SHALL HAVE A WHITE REFLECTORIZED LEGEND AND BORDER ON A GREEN REFLECTORIZED BACKGROUND, TYPE A SHEETING.
  - THE SIGN LENGTH SHOULD BE INCREASED IN 6-INCH INCREMENTS, BUT THE OVERALL LENGTH SHOULD NOT EXCEED 6'-0".
  - ALL BORDERS SHALL BE 3/4" WIDE AND CORNER RADIUS SHALL BE 2-1/4".
  - SIGNFIX ALUMINUM CHANNEL FRAMING SYSTEM SHALL BE USED FOR ALL SIGNS ATTACHED TO SIGNAL POLES AND POSTS. LOCAL SUPPLIERS OF THE SIGNFIX ALUMINUM CHANNEL FRAMING SYSTEM ARE:
    - \* A.K.T. CORPORATION
    - \* AMERICAN FABRICATION CO.
    - SCHAUMBURG, IL
    - CHICAGO HEIGHTS, IL
    - \* TUCKER COMPANY, INC.
    - \* WESTERN TRAFFIC CONTROL INC.
    - WAUWATOSA, WI
    - CICERO, IL
- PARTS LISTING:
- |              |   |
|--------------|---|
| SIGN CHANNEL | PART #HPN053 (MED. CHANNEL)                   |
| SIGN SCREWS  | 1/4" X 14 X 1" H.W.H. #3                      |
|              | SELF TAPPING WITH NEOPRENE WASHER             |
| BRACKETS     | PART #HPN034 (UNIVERSAL)                      |
|              | CHANNEL CLAMPS WITH STAINLESS STEEL STRAPPING |
- OTHER BRANDS OF MOUNTING HARDWARE ARE ACCEPTABLE, BASED UPON THE DEPARTMENT'S APPROVAL AND COMPATIBILITY WITH THE CHANNEL/BRACKET OF THE ABOVE PRODUCT.