

\*Grind anchor rod to bright finish at ground clamp location before installing clamp.

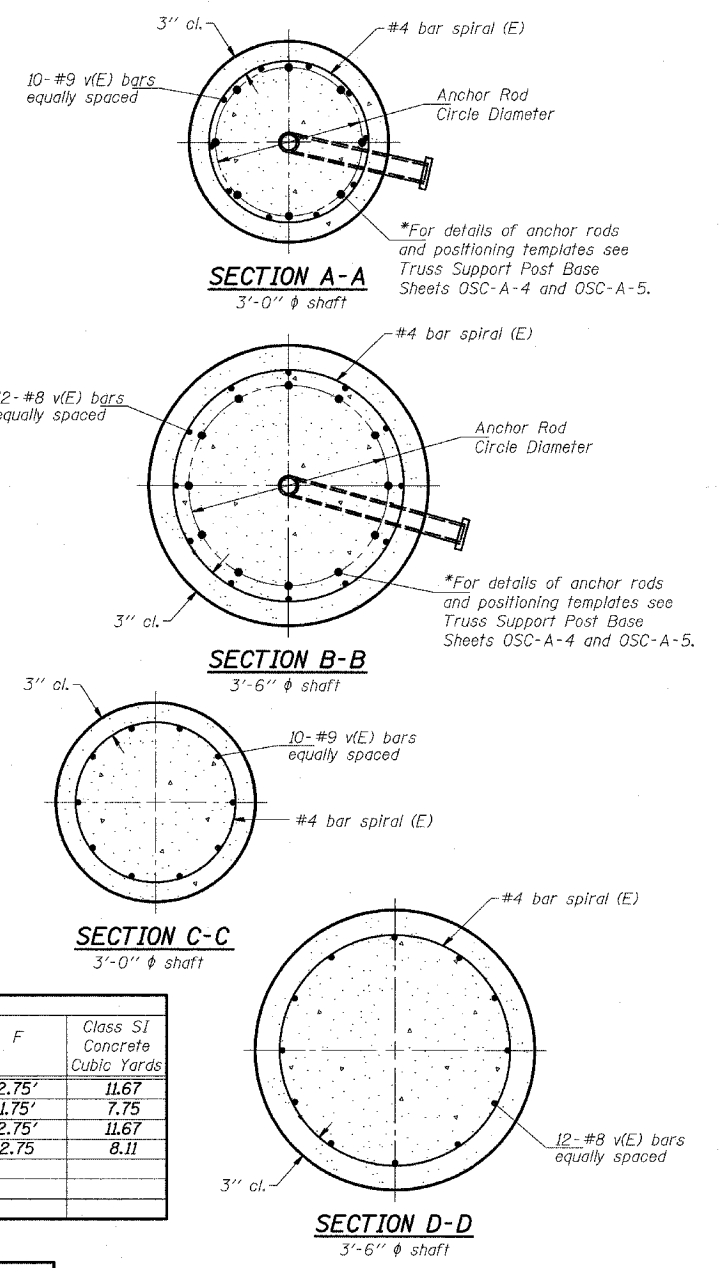
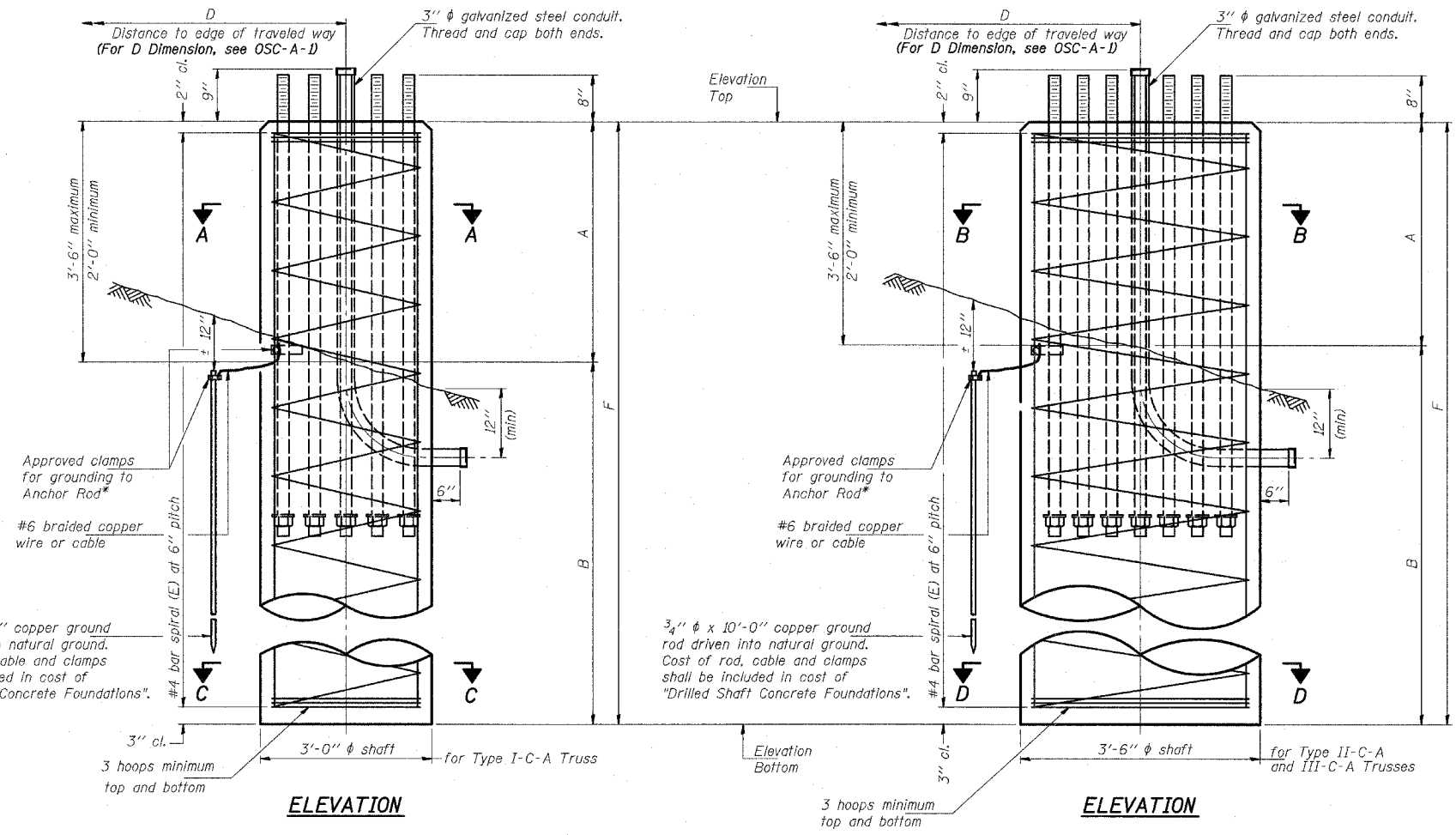

**NOTES:**  
 The Foundation dimensions shown in the Foundation Design Table are based on the presence of mostly cohesive soils with an average Unconfined Compressive Strength (Qu) of at least 1.25 tsf, which must be determined by previous soil investigations at the jobsite. When other conditions are indicated, the boring data will be included in the plans and the Foundation dimensions shown in the Foundation Data Table will be the result of site specific designs.

to determine if the foundation dimensions need to be modified. If dimensions "B" or "F" are revised by more than 12" by the Contractor, "as-built" plans shall be prepared and submitted to the District Bureau of Operations for future reference.

No sonotubes or decomposable forms shall be used below the lower conduit entrance. Permanent metal forms or other shielding may not be left in place below that elevation without the Engineer's written permission.

Concrete shall be placed monolithically, without construction joints. Backfill shall be placed per Article 502 of Standard Specification and prior to erection of support column.

A normal surface finish followed by a Bridge Seal Sealer application will be required on concrete surfaces above the lowest elevation 6" below finished ground line. Cost included in "Drilled Shaft Concrete Foundation".

Structure Number	Station	Truss Type	Shaft Diameter	Elevation Top	Elevation Bottom	A	B	F	Class SI Concrete Cubic Yards
IC0161057L357.8	117+30	III-C-A	3.5'	7.51	-25.24	2.75'	30'	32.75'	11.67
IC0161057R063.0	144+75	III-C-A	3.5'	6.88	-14.87	2.75'	19'	21.75'	7.75
IC0161094R062.6	1216+75	III-C-A	3.5'	6.08	-26.67	2.75'	30'	32.75'	11.67
*IC0161094R062.4	1227+50	III-C-A	3.5'	3.51	-29.24	2.75'	30'	32.75'	8.11

Truss Type	Post Base Sheet	Maximum Cantilever Length (ft)	Maximum Total Sign Area (sq ft)	Shaft Diameter (ft)	"B" Depth (ft)	Anchor Rods		Anchor Rod Circle Diameter (in)
						No.	Diameter (in)	
I-C-A	OSC-A-4	25	170	3.0	15.5	8	2	22
II-C-A	OSC-A-5	30	170	3.5	15.0	12	2	30
II-C-A	OSC-A-5	30	340	3.5	21.5	12	2	30
III-C-A	OSC-A-5	35	170	3.5	19.0	12	2	30
III-C-A	OSC-A-5	35	250	3.5	22.5	12	2	30
III-C-A	OSC-A-5	35	400	3.5	26.5	12	2	30
III-C-A	OSC-A-5	40	400	3.5	30.0	12	2	30

NUMBER	REVISION	DATE

\*BOTTOM 10' OF FOUNDATION (FROM EL. -19.24 TO EL. -29.24) IS PAID FOR AS DRILLED SHAFT IN ROCK 42".

OSC-A-9 11/1/2002

TYLIN INTERNATIONAL

NAME	DATE

ILLINOIS DEPARTMENT OF TRANSPORTATION  
 F.A.I. 94 (DAN RYAN EXPRESSWAY)  
**CANTILEVER SIGN STRUCTURES  
 DRILLED SHAFT  
 ALUMINUM TRUSS & STEEL POST**

SCALE: AS NOTED      DRAWN BY: AMB  
 DATE: MARCH 25, 2005      CHECKED BY: TB

3/30/2005 12:44:16 PM