

62890

F.A.P. RTE.	SECTION	COUNTY	TOTAL SHEETS	SHEET NO.
1238	2004-125 TS	LAKE	18	1
D-91-086-05				

INDEX OF SHEETS

1. TITLE SHEET
2. SUMMARY OF QUANTITIES
- 3-6. STANDARD TRAFFIC SIGNAL DESIGN DETAILS
7. TRAFFIC SIGNAL MODIFICATION PLAN - IL. RTE. 176 AT BRADLEY RD.
8. CABLE PLAN, PHASE DESIGNATION DIAGRAM, EMERGENCY VEHICLE PREEMPTION SEQUENCE AND SCHEDULE OF QUANTITIES - IL. RTE. 176 AT BRADLEY RD.
9. TRAFFIC SIGNAL MODIFICATION PLAN - IL. RTE. 176 AT EAST OF I-94 RAMP/ LAMBS FARM ENTRANCE
10. CABLE PLAN, PHASE DESIGNATION DIAGRAM, EMERGENCY VEHICLE PREEMPTION SEQUENCE AND SCHEDULE OF QUANTITIES - IL. RTE. 176 AT EAST OF I-94 RAMP/LAMP FARM ENTRANCE
11. TRAFFIC SIGNAL MODIFICATION PLAN - IL. RTE. 176 WEST OF I-94 RAMP
12. CABLE PLAN, PHASE DESIGNATION DIAGRAM, EMERGENCY VEHICLE PREEMPTION SEQUENCE AND SCHEDULE OF QUANTITIES - IL. RTE. 176 AT WEST OF I-94 RAMP
- 13-14. TRAFFIC SIGNAL MODIFICATION PLAN - IL. RTE. 176 AT ST. MARY'S RD.
15. CABLE PLAN, PHASE DESIGNATION DIAGRAM, EMERGENCY VEHICLE PREEMPTION SEQUENCE AND SCHEDULE OF QUANTITIES - IL. RTE. 176 AT ST. MARY'S RD.
- 16-17. INTERCONNECT PLAN - ILL. RTE. 176 FROM ST. MARY'S RD. TO BRADLEY RD.
18. INTERCONNECT SCHEMATIC

STATE OF ILLINOIS
DEPARTMENT OF TRANSPORTATION

DIVISION OF HIGHWAYS
**PLANS FOR PROPOSED
FEDERAL AID HIGHWAY**

DISTRICT 1
**CONGESTION MITIGATION AIR QUALITY
FIBER OPTIC COMMUNICATIONS NETWORK
FAU ROUTE 1238/ILL. ROUTE 176 (PARK AVE.)
FROM ST. MARY'S ROAD TO BRADLEY ROAD
SECTION 2004-125 TS
LAKE COUNTY
C-91-086-05
PROJECT: CMM-1238(008)**



STANDARDS

701006-02	702001-05	880006	701801-03
701011-01	424001-03	701501-03	
701101-01	814001	701606-04	
701301-02	857001	701701-04	

IMPROVEMENT LOCATED IN THE VILLAGE OF LIBETVILLE, ILLINOIS

PROJECT BEGINS

PROJECT ENDS

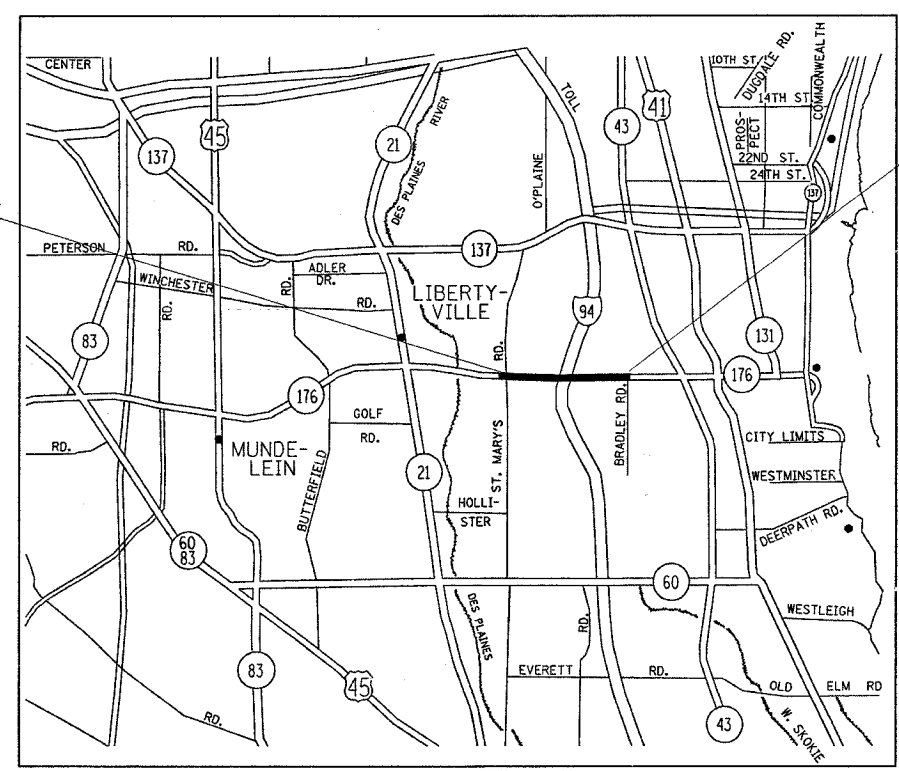

LENGTH OF IMPROVEMENT = 1.2 MI
LIBERTYVILLE TOWNSHIP
LOCATION MAP

SCALE PLAN 1" = 20'
INTERCONNECT 1" = 50'

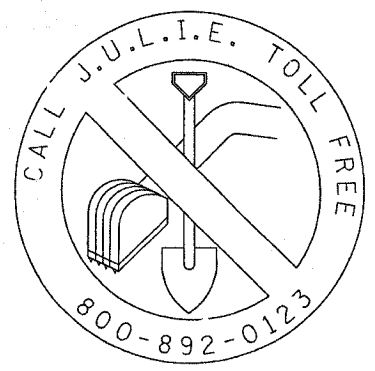

48 - HOURS BEFORE DIGGING

STATE OF ILLINOIS
DEPARTMENT OF TRANSPORTATION
DIVISION OF HIGHWAYS

SUBMITTED March 4 2005
Deane M. O'Keefe, Ed.
DEPUTY DIRECTOR OF HIGHWAYS, REGION ENGINEER

May 13 2005
Mike Hane
ENGINEER OF DESIGN AND ENVIRONMENT

May 13 2005
Victor Mader
DIRECTOR OF HIGHWAYS, CHIEF ENGINEER

PRINTED BY AUTHORITY OF THE STATE OF ILLINOIS

PREPARED BY: Terry Rammacher 3/4/05
TRAFFIC ENGINEER DATE

CONTRACT NO. 62890

BUREAU OF TRAFFIC: TERRY RAMMACHER / DARYLE DREW (847) 705-4420

F.A.U. RTE.	SECTION	COUNTY	TOTAL SHEETS	SHEET NO.
1238	2004-125 TS	LAKE	18	2
STA.		TO STA.		
FED. ROAD DIST. NO. 1		ILLINOIS	FED. AID PROJECT	
CONTRACT #62890				

SUMMARY OF QUANTITIES

PERCENTAGES									
LOCATION OF WORK				ILL. RTE. 176 AT ST. MARY'S RD.	ILL. RTE. 176 AT WEST OF I-94 RAMP	ILL. RTE. 176 AT EAST OF I-94 RAMP/LAMBS FARM ENTRANCE	ILL. RTE. 176 AT BRADLEY RD	INTERCONNECT ILL. RTE. 176 ST. MARY'S TO BRADLEY RD	
SUMMARY OF QUANTITIES				URBAN 801.FED. 201.STATE	CONSTRUCTION CODE TYPE				
CODE NUMBER	ITEM	UNIT	TOTAL QUANTITIES	Y031-1F	Y031-1F	Y031-1F	Y031-1F	Y031-1F	
67000400	ENGINEER'S FIELD OFFICE, TYPE A	CAL MO	4	-	-	-	-	-	
67100100	MOBILIZATION	L SUM	1	-	-	-	-	-	
70102620	TRAFFIC CONTROL AND PROTECTION, STANDARD 701501	L SUM	1	0.2	0.2	0.2	0.2	0.2	
70102630	TRAFFIC CONTROL AND PROTECTION, STANDARD 701601	L SUM	1	0.2	0.2	0.2	0.2	0.2	
70102635	TRAFFIC CONTROL AND PROTECTION, STANDARD 701701	L SUM	1	0.2	0.2	0.2	0.2	0.2	
70102640	TRAFFIC CONTROL AND PROTECTION, STANDARD 701801	L SUM	1	0.2	0.2	0.2	0.2	0.2	
81000600	CONDUIT IN TRENCH, 2" DIA., GALVANIZED STEEL	FOOT	2380	-	-	-	-	2380	
81018500	CONDUIT PUSHED, 2" DIA., GALVANIZED STEEL	FOOT	120	-	-	-	-	120	
81400200	HEAVY-DUTY HANDHOLE	EACH	4	-	-	-	-	4	
81500200	TRENCH AND BACKFILL FOR ELECTRICAL WORK	FOOT	2380	-	-	-	-	2380	
85000200	MAINTENANCE OF EXISTING TRAFFIC SIGNAL INSTALLATION	EACH	4	1	1	1	1	-	
85700205	FULL-ACTUATED CONTROLLER AND TYPE IV CABINET(SPECIAL)	EACH	3	-	1	1	1	-	
86400100	TRANSCEIVER - FIBER OPTIC	EACH	3	-	1	1	1	-	
87301305	ELECTRIC CABLE IN CONDUIT, LEAD-IN, NO. 14 1 PAIR	FOOT	490	-	-	-	490	-	
87301805	ELECTRIC CABLE IN CONDUIT, SERVICE, NO. 6 2C	FOOT	215	-	115	35	65	-	
87900200	DRILL EXISTING HANDHOLE	EACH	2	-	-	-	-	2	
88200210	TRAFFIC SIGNAL BACKPLATE, LOUVERED, ALUMINUM	EACH	16	-	4	6	6	-	
88500100	INDUCTIVE LOOP DETECTOR	EACH	16	-	4	6	6	-	
88800100	PEDESTRIAN PUSHBUTTON	EACH	4	-	-	2	2	-	
89502300	REMOVE ELECTRIC CABLE FROM CONDUIT	FOOT	250	-	125	45	80	-	
89502375	REMOVE EXISTING TRAFFIC SIGNAL EQUIPMENT	EACH	3	-	1	1	1	-	
X0322925	ELECTRIC CABLE IN CONDUIT, TRACER NO. 14 1C	FOOT	3230	-	-	-	-	3230	
X8050015	SERVICE INSTALLATION, POLE MOUNT	EACH	3	-	1	1	1	-	
X8710020	FIBER OPTIC CABLE IN CONDUIT, NO. 62.5/125, MM12F SM12F	FOOT	3230	-	-	-	-	3230	
X8730027	ELECTRIC CABLE IN CONDUIT, GROUNDING, NO. 6 1C	FOOT	215	-	115	35	65	-	
X8800020	SIGNAL HEAD, L.E.D., 1-FACE, 3-SECTION MAST ARM MOUNTED	EACH	9	-	2	3	4	-	
X8800035	SIGNAL HEAD, L.E.D., 1-FACE, 3-SECTION BRACKET MOUNTED	EACH	10	-	3	5	2	-	
X8800038	SIGNAL HEAD, L.E.D., 1-FACE, 4-SECTION MAST ARM MOUNTED	EACH	2	-	-	2	-	-	
X8800040	SIGNAL HEAD, L.E.D., 1-FACE, 5-SECTION BRACKET MOUNTED	EACH	2	-	-	1	1	-	
X8800045	SIGNAL HEAD, L.E.D., 1-FACE, 5-SECTION MAST ARM MOUNTED	EACH	3	-	-	1	2	-	
X8800010	SIGNAL HEAD, L.E.D., 1-FACE, 1-SECTION, MAST ARM MOUNTED	EACH	2	-	2	-	-	-	
X8805280	SIGNAL HEAD, L.E.D., 2-FACE, 1-3-SECTION, 1-5-SECTION, BRACKET MOUNTED	EACH	1	-	-	-	1	-	
X8810610	PEDESTRIAN SIGNAL HEAD, L.E.D., 1-FACE, BRACKET MOUNTED	EACH	4	-	-	2	2	-	
X002856	RE-OPTIMIZE TRAFFIC SIGNAL SYSTEM	LSUM	1	.25	.25	.25	.25	-	

REVISIONS		ILLINOIS DEPARTMENT OF TRANSPORTATION SUMMARY OF QUANTITIES ILL. RTE. 176 (PARK AVE.) ST. MARY'S TO BRADLEY RD.
NAME	DATE	
SCALE: NONE		DRAWN BY: SM DESIGNED BY: SM CHECKED BY: DAD
DATE: 01-05-2005		

c:\projects\traffic\013200\11768bradley.m32
 2/7/2005

F.A.B. RTE.	SECTION	COUNTY	TOTAL SHEETS	SHEET NO.
1238	2004-125 TS	LAKE	18	3
STA.		TO STA.		
FED. ROAD DIST. NO. 1		ILLINOIS FED. AID PROJECT		
CONTRACT NO. 62890				

LOOP DETECTOR NOTES

- EACH PAIR OF LOOP WIRES SHALL BE PLACED IN A SEPARATE UNIT DUCT FROM THE EDGE OF PAVEMENT TO THE HANDHOLE. SPACING BETWEEN THE HOLES DRILLED IN THE PAVEMENT SHALL NOT BE LESS THAN 6" (150 mm). UNIT DUCT SHALL BE INCLUDED IN THE COST OF THE LOOP WIRE.
- THE NUMBER OF LOOP TURNS SHALL BE AS RECOMMENDED BY THE AMPLIFIER MANUFACTURER. ALL ADJACENT SIDES OF THE LOOPS SHALL BE INSTALLED IN SUCH A WAY THAT THE CURRENT FLOW IS IN THE SAME DIRECTION TO REINFORCE ITS MAGNETIC FIELDS FOR SMALL VEHICLE DETECTION.
- EACH LOOP LEAD-IN SHALL BE IDENTIFIED AND PERMANENTLY TAGGED IN THE HANDHOLE. EACH LEAD-IN CABLE TAG SHALL INDICATE THE LOCATION OF THE LOOP, LOOP ROTATION (CLOCKWISE/COUNTERCLOCKWISE), LOOP LEAD-IN DIRECTION (IN OR OUT), LOOP CABLE NUMBER AND LOCATION IN CABINET, AND NUMBER OF TURNS IN THE DETECTOR LOOPS IN WATER PROOF INK AS INDICATED ON THE DISTRICT 1 STANDARD TRAFFIC SIGNAL DESIGN DETAIL. THE CONTRACTOR SHALL MARK LOOP LOCATIONS ON RECORD DRAWINGS AND PRESENT TO THE ENGINEER AFTER FINAL INSPECTION. LOOPS SHALL BE MARKED BY LANE AND LOOP NUMBER. SEE DETAIL BELOW.
- ALL LOOP CABLE SHALL BE FASTENED WITH PLASTIC TIE WRAP TO THE HANDHOLE HOOKS.
- IN ASPHALT PAVEMENT, LOOPS SHOULD BE PLACED IN THE BINDER AND DIVEHOLES MARKED AT THE CURB WITH A SAW-CUT. THE SAW-CUT SHALL BE CUT IN ACCORDANCE WITH LOCAL AND E.P.A. DUST CONTROL REQUIREMENTS. DETECTOR LOOP(S) SHALL NOT BE INSTALLED IN WET CONDITIONS AND THE SAW-CUTS MUST BE FREE OF DEBRIS AND RESIDUE SUCH AS DUST AND WATER WHICH IS TO BE ACHIEVED BY THE USE OF COMPRESSED AIR, WIRE BRUSHING AND HEAT DRYING ACCORDING TO SEALANT MANUFACTURER REQUIREMENTS. THE DETECTOR WIRE SHALL BE HELD IN PLACE BY THE USE OF FORM WEDGES. WEDGES SHALL BE SPACED NO MORE THAN 18" (450 mm) APART.
- LOOP SPLICES SHALL BE SOLDERED USING A SOLDERING IRON. BLOW TORCHES OR OTHER DEVICES WHICH OXIDIZE COPPER CABLE SHALL NOT BE ALLOWED FOR SOLDERING OPERATIONS. SEE DETAIL BELOW RIGHT.
- PERFORMED DETECTOR LOOPS SHALL BE USED, AS SHOWN ON THE PLANS, WHERE NEW CONCRETE PAVEMENT IS PROPOSED. THE INSTALLATION OF PERFORMED LOOPS SHALL BE IN ACCORDANCE WITH THE DISTRICT 1 SPECIFICATIONS OR AS DIRECTED BY THE ENGINEER.

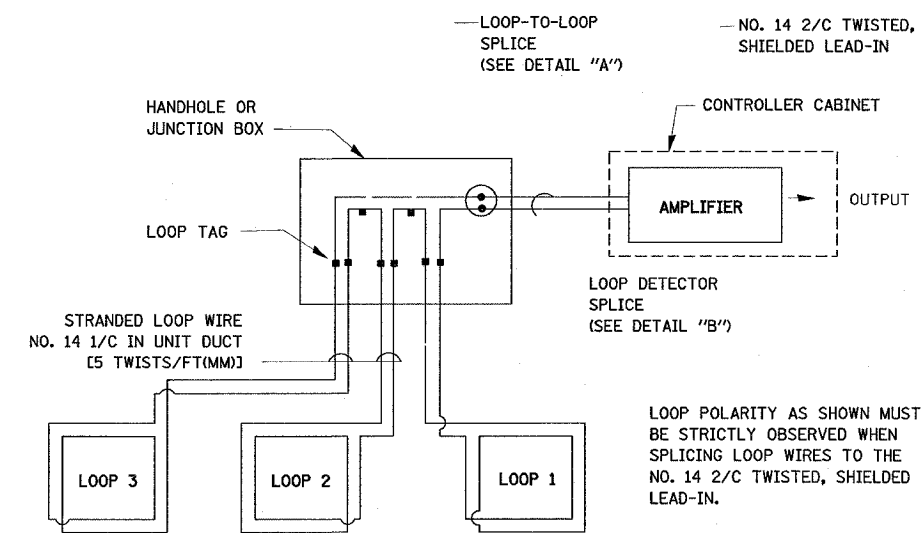

DETECTOR LOOP WIRING SCHEMATIC

- LOOPS SHALL BE SPLICED IN SERIES.
- SAW-CUTS SHALL BE A MINIMUM WIDTH OF 5/16" (8 mm).
- SAW-CUT DEPTHS SHALL BE 3" (75 mm). IF IN CONCRETE, THE SAW-CUT DEPTH SHALL BE TO THE TOP OF THE REINFORCEMENT.
- LOOP CORNERS SHALL BE DRILLED WITH A 2" (50 mm) DIAMETER CORE.

LOOP LEAD-IN CABLE TAG

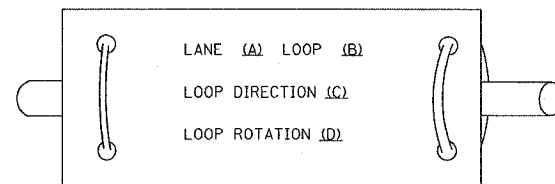

- LANE 1 IS THE LANE CLOSEST TO THE CENTERLINE OF THE ROADWAY
- LOOP #1 IS THE LOOP IN THE LANE CLOSEST TO THE INTERSECTION.
- LABEL LOOP CABLE "IN" OR LOOP CABLE "OUT".
- LABEL LOOP CABLE CLOCKWISE OR LOOP CABLE COUNTERCLOCKWISE.

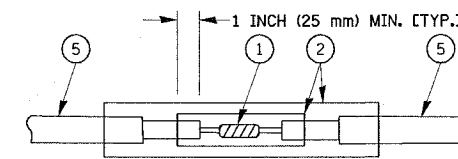

DETAIL "A"
LOOP-TO-LOOP SPLICE

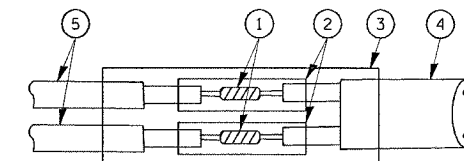

DETAIL "B"
LOOP-TO-CONTROLLER SPLICE

LOOP DETECTOR SPLICE

- WESTERN UNION SPLICE SOLDERED WITH ROSIN CORE FLUX. ALL EXPOSED SURFACES OF THE SOLDER SHALL BE SMOOTH.
- WCSMW 30/100 HEAT SHRINK TUBE, MINIMUM LENGTH 3" (75 mm), UNDERWATER GRADE.
- WCS 200/750 HEAT SHRINK TUBE, MINIMUM LENGTH 6" (150 mm), UNDERWATER GRADE.
- NO. 14 2/C TWISTED, SHIELDED CABLE.
- LOOP CONDUCTOR WITH FLEXIBLE PLASTIC TUBE.

REVISIONS	
NAME	DATE

ILLINOIS DEPARTMENT OF TRANSPORTATION
DISTRICT ONE
STANDARD TRAFFIC SIGNAL
DESIGN DETAILS

SCALE: VERT. NONE
HORIZ. NONE
DATE 1-01-02

DRAWN BY: RWP
DESIGNED BY: DAD
CHECKED BY: DAZ
SHEET 1 OF 4

F.A.U. RTE.	SECTION	COUNTY	TOTAL SHEETS	SHEET NO.
1238	2004-125 TS	LAKE	18	4
STA.		TO STA.		
FED. ROAD DIST. NO. 1		ILLINOIS	FED. AID PROJECT	
CONTRACT NO. 62890				

TRAFFIC SIGNAL MAST ARM AND POST

MAST ARM MOUNTED SIGNAL IN PROPOSED & FUTURE SIDEWALK AREA. INTERSECTION SHOWN WITH PEDESTRIAN SIGNAL AND PUSHBUTTON DETECTOR

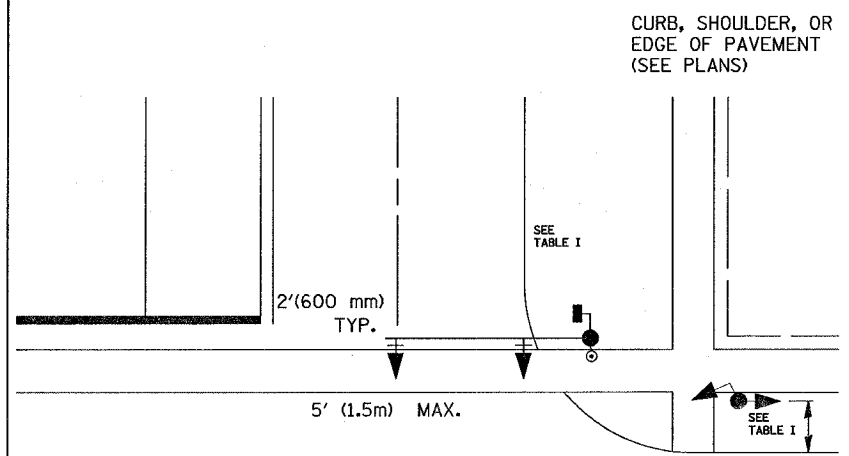

PEDESTRIAN SIGNAL PUSHBUTTON

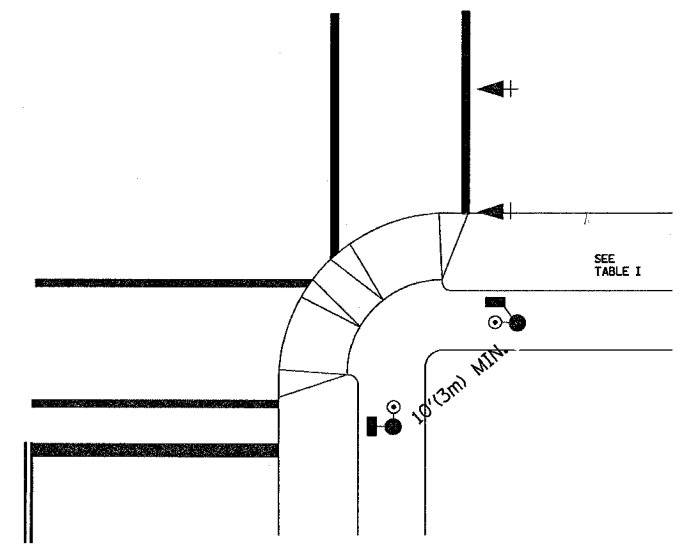

RECOMMENDED PUSHBUTTON LOCATIONS FOR ACCESSIBLE PEDESTRIAN SIGNALS SHALL BE IN ACCORDANCE WITH THE CURRENT MUTCD (SEE NOTE 1). TO MEET MUTCD REQUIREMENTS, PEDESTRIAN SIGNAL PUSHBUTTONS MAY HAVE TO BE MOUNTED ON A SEPARATE POST.

NOTES:

- AT ACCESSIBLE PEDESTRIAN SIGNAL LOCATIONS WITH PEDESTRIAN ACTUATION, EACH PUSHBUTTON SHALL ACTIVATE BOTH THE WALK INTERVAL AND THE ACCESSIBLE PEDESTRIAN SIGNALS.

AT ACCESSIBLE PEDESTRIAN SIGNAL LOCATIONS, PUSHBUTTONS SHOULD CLEARLY INDICATE WHICH CROSSWALK SIGNAL IS ACTUATED BY EACH PUSHBUTTON. PUSHBUTTONS AND TACTILE ARROWS SHOULD HAVE HIGH VISUAL CONTRAST (SEE THE DEPARTMENT OF JUSTICE'S AMERICANS WITH DISABILITIES ACT STANDARDS FOR ACCESSIBLE DESIGN, 1991). TACTILE ARROWS SHOULD POINT IN THE SAME DIRECTION AS THE ASSOCIATED CROSSWALK. AT CORNERS OF SIGNALIZED LOCATIONS WITH ACCESSIBLE PEDESTRIAN SIGNALS WHERE PEDESTRIAN PUSHBUTTONS ARE PROVIDED, THE PUSHBUTTONS SHOULD BE SEPARATED BY THE DISTANCE OF AT LEAST 10 FT (3m). THIS ENABLES PEDESTRIANS WHO HAVE VISUAL DISABILITIES TO DISTINGUISH AND LOCATE THE APPROPRIATE PUSHBUTTON.

PUSHBUTTONS FOR ACCESSIBLE PEDESTRIAN SIGNALS SHOULD BE LOCATED AS FOLLOWS:
 A: ADJACENT TO A LEVEL ALL-WEATHER SURFACE TO PROVIDE ACCESS FROM A WHEELCHAIR, AND WHERE THERE IS AN ALL WEATHER SURFACE, WHEELCHAIR ACCESSIBLE ROUTE TO THE RAMP.
 B: WITHIN 5 FT (1.5m) OF THE CROSSWALK EXTENDED.
 C: WITHIN 10 FT (3m) OF THE EDGE OF CURB, SHOULDER, OR PAVEMENT.
 D: PARALLEL TO THE CROSSWALK TO BE USED (SEE MUTCD FIGURE 4E-2).
 E: NORMAL PEDESTRIAN PUSHBUTTON MOUNTING HEIGHT SHOULD BE 3.5 FT (1.05m) ABOVE ADJACENT SIDEWALK
- PEDESTRIAN SIGNAL FACES SHALL BE MOUNTED WITH THE BOTTOM OF THE HOUSING NOT LESS THAN 8 FT (2.4m) NOR MORE THAN 10 FT (3.0m) ABOVE THE SIDEWALK LEVEL AND SO THERE IS A PEDESTRIAN INDICATION IN THE LINE OF PEDESTRIANS' VISION WHICH PERTAINS TO THE CROSSWALK BEING USED.
- THE BOTTOM OF THE HOUSING OF A VEHICLE SIGNAL FACE, NOT MOUNTED OVER A ROADWAY, SHALL BE AT LEAST 10 FT (3.0m) BUT NOT MORE THAN 15 FT (4.5m) ABOVE THE SIDEWALK OR, ABOVE THE PAVEMENT GRADE AT THE CENTER OF THE HIGHWAY IF NO SIDEWALKS EXIST.
- THE BOTTOM OF THE HOUSING OF A VEHICLE SIGNAL FACE, MOUNTED OVER A ROADWAY, SHALL BE ACCORDING TO CURRENT STATE STANDARDS 877001 AND 877006. (16 FT (5m) MIN., 18 FT (5.5m) MAX., FROM HIGHEST POINT OF PAVEMENT)

PEDESTRIAN SIGNAL POST

PEDESTRIAN SIGNAL HEAD AND PEDESTRIAN PUSHBUTTON DETECTOR LOCATION

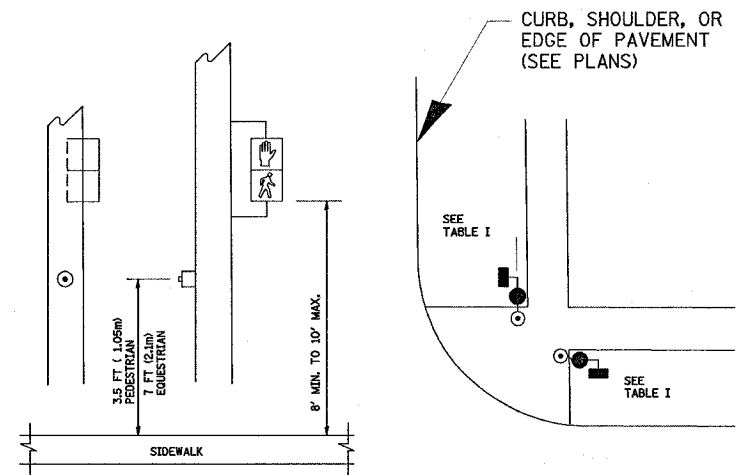

TABLE I

TRAFFIC SIGNAL EQUIPMENT	COMBINATION CONCRETE CURB AND GUTTER (MIN. DIST. FROM BACK OF CURB)	SHOULDER/NON-CURBED AREA (MIN. DIST. FROM EDGE OF PAVEMENT)
TRAFFIC SIGNAL MAST ARM POLE	6 FT (1.8m)	SHOULDER WIDTH + 2FT(0.6m), MINIMUM 10FT(3.0m)
TRAFFIC SIGNAL POST	4 FT (1.2m)	SHOULDER WIDTH + 2FT(0.6m), MINIMUM 10FT(3.0m)
PEDESTRIAN SIGNAL POST	4 FT (1.2m)	SHOULDER WIDTH + 2FT(0.6m), MINIMUM 10FT(3.0m)
PEDESTRIAN PUSHBUTTON	SEE NOTE 1	SEE NOTE 1

REVISIONS	
NAME	DATE

ILLINOIS DEPARTMENT OF TRANSPORTATION

DISTRICT 1
STANDARD TRAFFIC SIGNAL
DESIGN DETAILS

SCALE: VERT. NONE
HORIZ. NONE
DATE 1-01-02

DRAWN BY: RWP
DESIGNED BY: DAD
CHECKED BY: DAZ
SHEET 2 OF 4

c:\projects\traffic\1013200\1176\bradley.m32

F.A.U. RTE.	SECTION	COUNTY	TOTAL SHEETS	SHEET NO.
1238	2004-125 TS	LAKE	18	5
STA.	TO STA.			
FED. ROAD DIST. NO.	ILLINOIS	FED. AID PROJECT		
CONTRACT NO. 62890				

NOTES:

GROUNDING SYSTEM

1. THE GROUNDING SYSTEM SHALL CONSIST OF AN INSULATED CONDUCTOR TYPE XLP, NO. 6 A.W.G., STRANDED COPPER TO BE INSTALLED IN RACEWAYS. THE GROUNDING CABLE SHALL BE INSTALLED IN A CONTINUOUS MANNER AS SHOWN ON THE CABLE PLAN PROVIDED. ALL GROUNDING CONDUCTORS SHALL BE BONDED TO METAL ENCLOSURE (HANDHOLE, POST, MAST ARM, CONTROLLER, ETC.). GROUND ROD SHALL BE 3/4" DIA. x 10'-0" (20mm x 3.0m) LONG, COPPER CLAD. ONE GROUND ROD SHALL BE INSTALLED AT ALL POST FOUNDATIONS, POLE FOUNDATIONS, CONTROLLER CABINET FOUNDATION AND ELECTRICAL SERVICE INSTALLATION AS INDICATED ON THE CABLE PLAN. IF THERE ARE ANY SPECIAL CONDITIONS SUCH AS SUB-SURFACE CONDITIONS OR INSTALLATION PROBLEMS, THE RESIDENT ENGINEER SHALL BE NOTIFIED OR CONTACT THE BUREAU OF TRAFFIC, ILLINOIS DEPARTMENT OF TRANSPORTATION DISTRICT ONE AT (847) 705-4139.
2. THE NEUTRAL CONDUCTOR AND THE GROUND CONDUCTOR SHALL BE CONNECTED IN THE SERVICE INSTALLATION. AT NO OTHER POINT IN THE TRAFFIC SIGNAL SYSTEM SHALL THE NEUTRAL AND GROUND CONDUCTORS BE CONNECTED.
3. ALL EQUIPMENT GROUNDING CONDUCTORS SHALL TERMINATE AT THE GROUND BUS IN THE CONTROLLER CABINET.
4. THE CONTRACTOR SHALL PROVIDE A GROUND CABLE WITH CONNECTORS BETWEEN THE HANDHOLE COVER AND HANDHOLE FRAME.

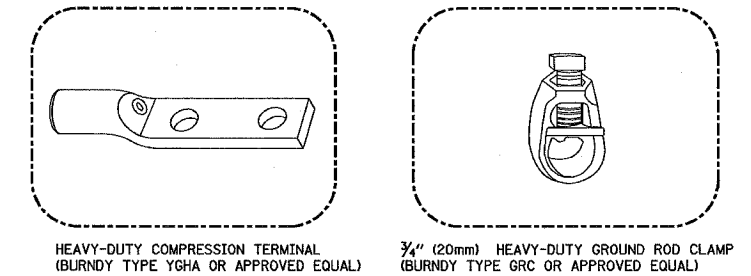
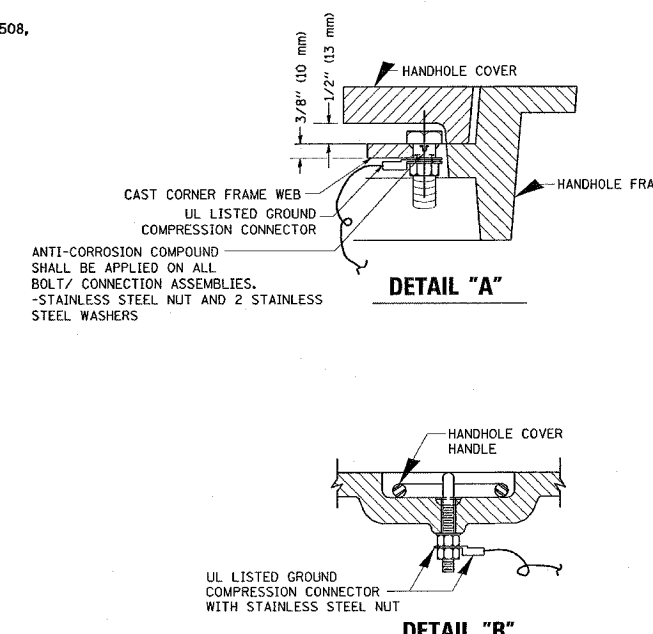

NOTES:

- ALL CLAMPS SHALL BE BRONZE OR COPPER, UL APPROVED.
- GROUND CABLE SHALL BE LOOPED OVER HOOKS IN THE HANDHOLES. 6.5' (2.0m) SLACK SHALL BE PROVIDED IN SINGLE HANDHOLES. 13' (4.0m) OF SLACK SHALL BE PROVIDED IN DOUBLE HANDHOLES. 5' (1.4m) OF SLACK SHALL BE PROVIDED BETWEEN FRAME AND COVER.

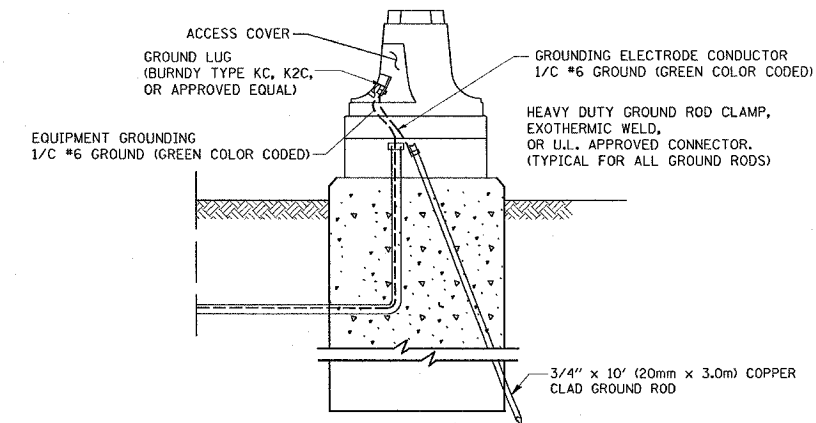
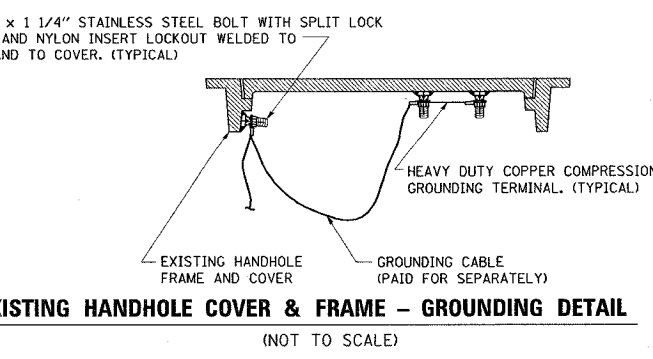
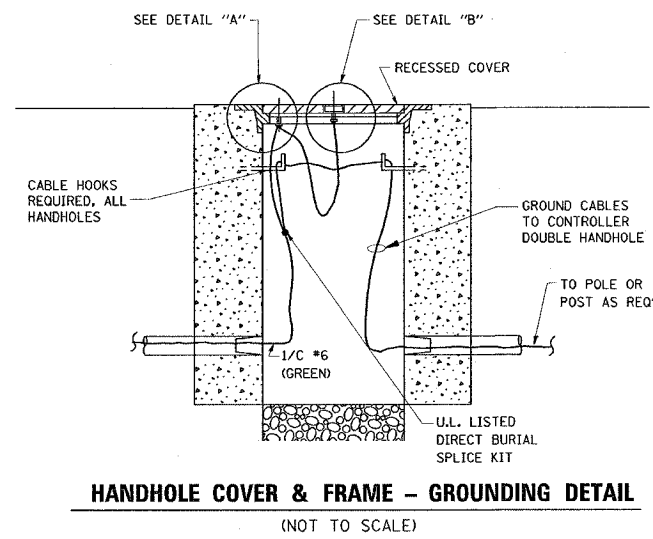

REVISIONS	
NAME	DATE

ILLINOIS DEPARTMENT OF TRANSPORTATION
DISTRICT 1
STANDARD TRAFFIC SIGNAL
DESIGN DETAILS

SCALE: VERT. NONE
 HORIZ. NONE
 DATE 1-01-02

DRAWN BY: RWP
 DESIGNED BY: DAD
 CHECKED BY: DAZ
 SHEET 3 OF 4

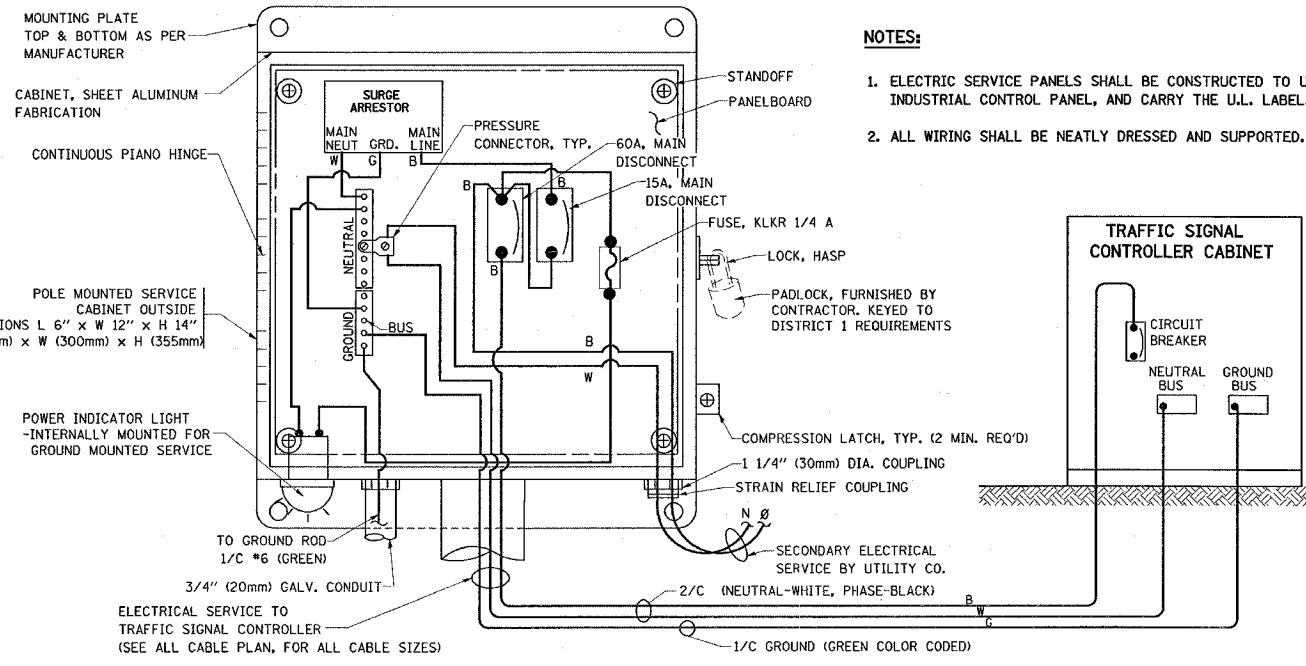

ELECTRICAL SERVICE - PANEL DIAGRAM (TYPICAL FOR POLE AND GROUND MOUNTED SERVICE)
SERVICE INSTALLATION POLE MOUNT (SHOWN)
 (NOT TO SCALE)

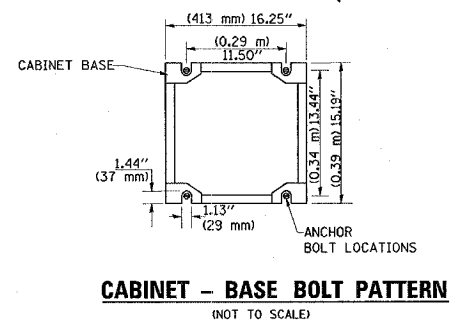
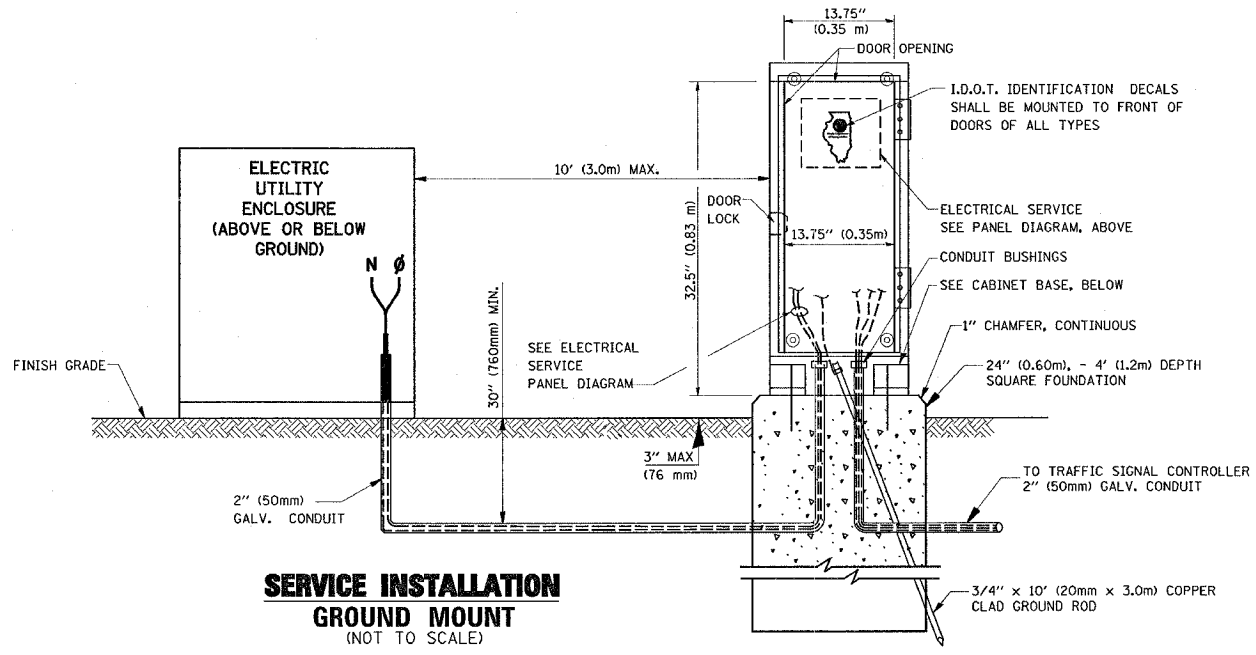

c:\projects\tr\aff\1013200\1176br\cabley.m32 2/4/2005 c:\projects\tr\aff\1013200\1176br\cabley.m32

F.A.U. RTE.	SECTION	COUNTY	TOTAL SHEETS	SHEET NO.
1238	2004-125 TS	LAKE	18	6
STA.	TO STA.			
FED. ROAD DIST. NO.	ILLINOIS	FED. AID PROJECT		
CONTRACT NO. 62890				

MATERIAL:
 - ASTM A48 CLASS 30 GREY IRON
 - ASTM A123 HOT DIPPED GALVANIZED

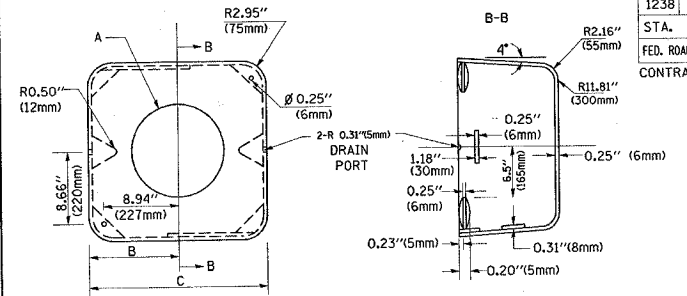

TYPE	A	B	C	HEIGHT	WEIGHT
I	Ø 10.125" (257mm)	9.5" (241mm)	19" (483mm)	12" (300mm)	24kg
II	Ø 11.125" (283mm)	10.75" (273mm)	21.5" (546mm)	12" (300mm)	26kg

SHROUD DETAIL

NOTE:
 SUPPORT EXISTING CABINET AND CONTROL EQUIPMENT ABOVE FOUNDATION TO KEEP TRAFFIC SIGNAL FUNCTIONING WHILE FOUNDATION MODIFICATION WORK IS PROCEEDING.

DIMENSION 7" (175mm) LARGER THAN CONTROLLER BASE DIMENSION, BOTH DIRECTIONS

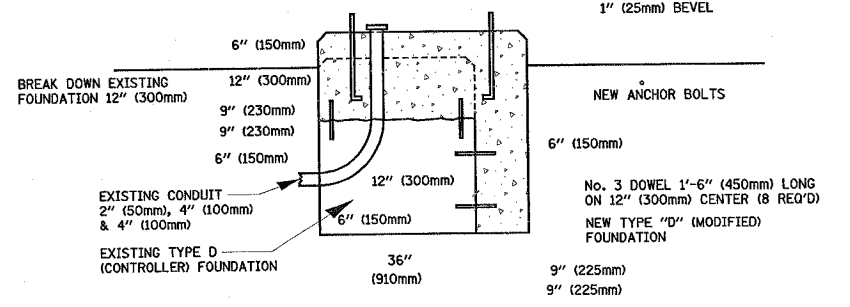

MODIFY EXISTING TYPE "D" FOUNDATION

(NOT TO SCALE)

NOTES:
 1. REMOVAL OF EXISTING CONDUIT FROM THE HANDHOLE AND THE INSTALLATION OF THE CONDUIT BUSHING SHALL BE INCIDENTAL TO THE HANDHOLE.

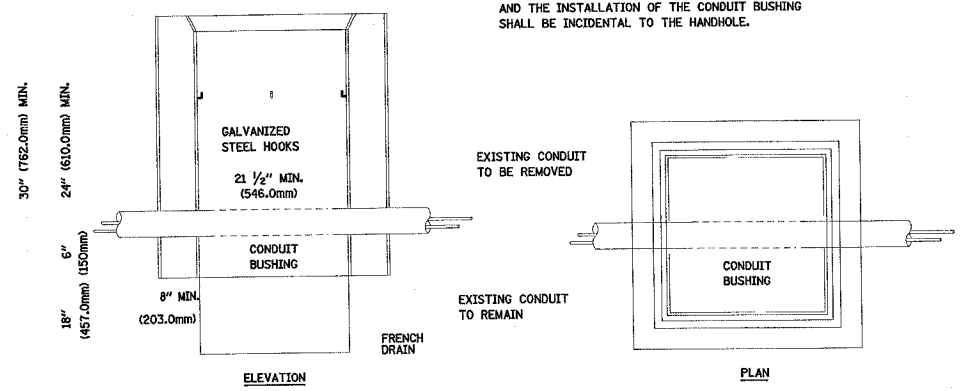

HANDHOLE TO INTERCEPT EXISTING CONDUIT

ILLINOIS DEPARTMENT OF TRANSPORTATION
 DISTRICT 1
 STANDARD TRAFFIC SIGNAL
 DESIGN DETAILS

SCALE: VERT. NONE
 HORIZ. 1"=1'-0"
 DATE: 1-01-02
 DRAWN BY: RWP
 DESIGNED BY: DAD
 CHECKED BY: DAZ
 SHEET 4 OF 4

REVISIONS	
NAME	DATE

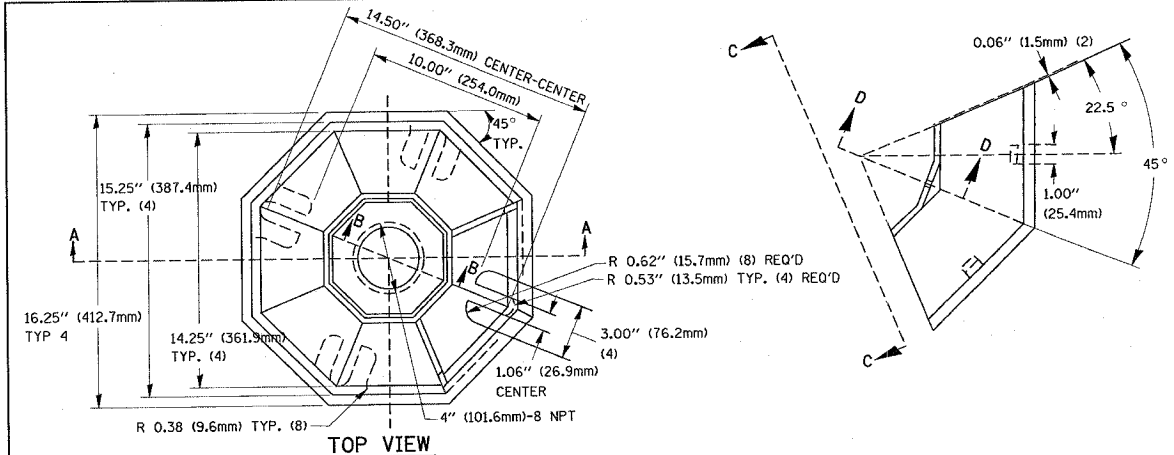

TOP VIEW

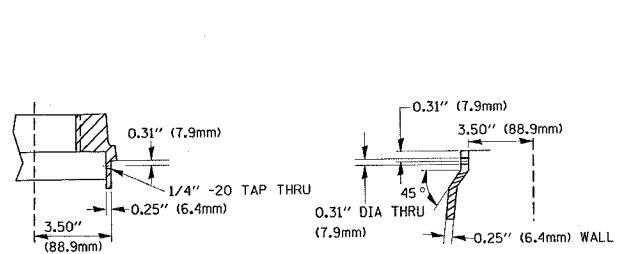

SECTION B-B

SECTION D-D

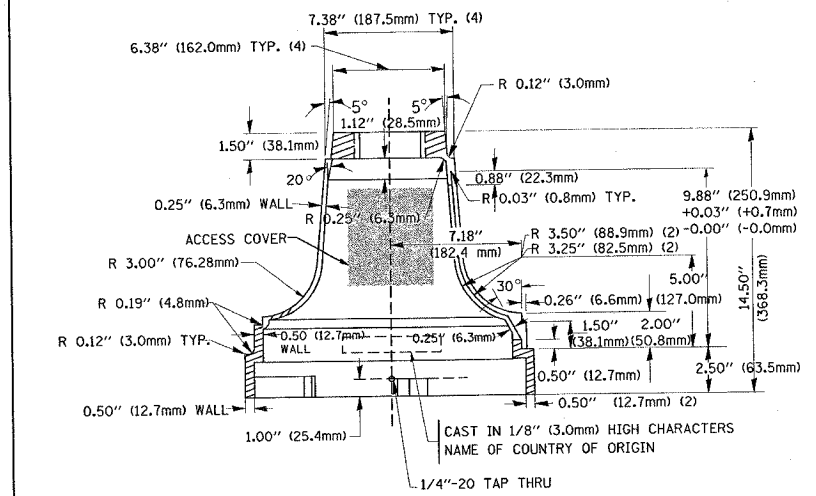

SECTION A-A

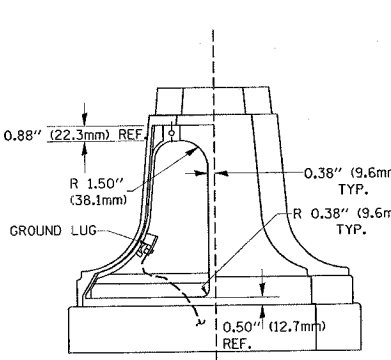

VIEW C-C

TRAFFIC SIGNAL POST - MOUNTING BASE - TYPE A

NOTES:

- ALL ELECTRICAL ITEMS, EXCEPT ITEMS #2 AND #11 SHALL BE ALUMINUM OR GALVANIZED
- ITEM #1- OZ/GEDNEY FSX-1-50 OR EQUIVALENT
 ITEM #2- MULBERRY CON-O-SHADE LAMP SHIELD OR EQUIVALENT
 ITEM #9- "BAND-IT" SADDLE BRACKET OR EQUIVALENT
- WHEN POST MOUNTING IS SPECIFIED, ITEM #9 SHALL NOT BE REQUIRED. THE DETECTION UNIT SHALL BE MOUNTED DIRECTLY ON TOP OF THE CAP BY DRILLING AND TAPPING A 3/4" (19 mm) HOLE WITH PIPE THREADS. THE POST CAP SHALL EITHER BE SCREWED TO THE TOP OF THE POST OR A MINIMUM OF 3 TIGHTENING SCREWS SHALL BE REQUIRED ON EACH CAP.

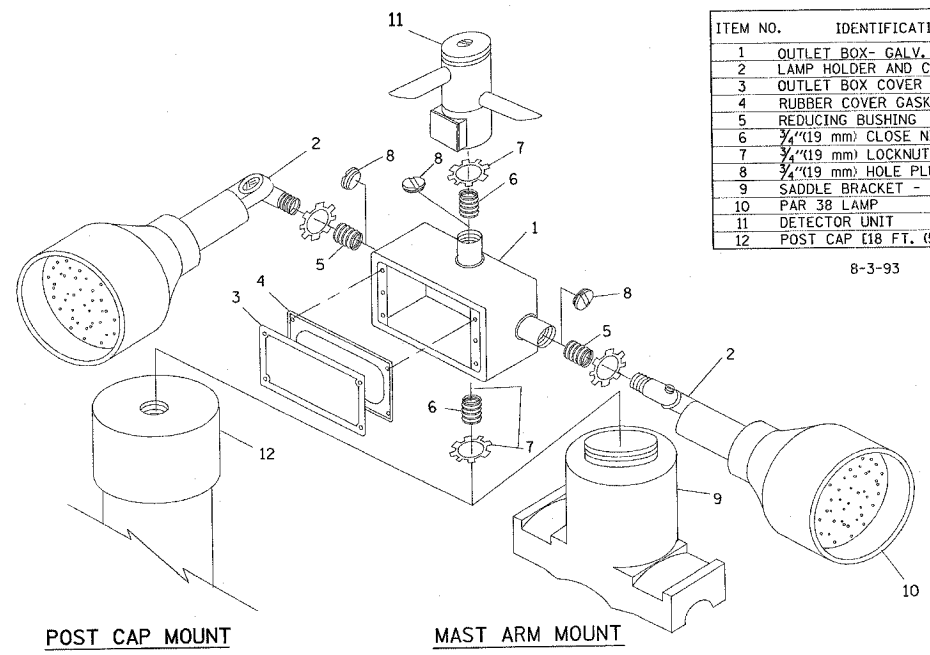

EMERGENCY VEHICLE DETECTOR WITH CONFIRMATION BEACON MOUNTING DETAIL

ITEM NO.	IDENTIFICATION
1	OUTLET BOX- GALV. 21 CU.IN. (0.000344 CU-M)
2	LAMP HOLDER AND COVER
3	OUTLET BOX COVER
4	RUBBER COVER GASKET
5	REDUCING BUSHING
6	3/4" (19 mm) CLOSE NIPPLE
7	3/4" (19 mm) LOCKNUT
8	3/4" (19 mm) HOLE PLUG
9	SADDLE BRACKET - GALV.
10	PAR 38 LAMP
11	DETECTOR UNIT
12	POST CAP [18 FT. (5.4 m) POST MIN.]

8-3-93

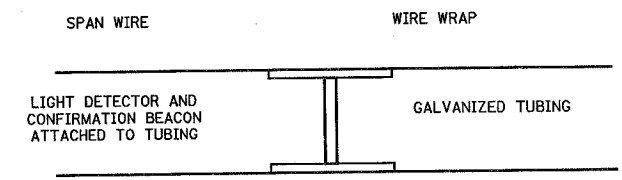

LIGHT DETECTOR AND CONFIRMATION BEACON MOUNTING FOR TEMPORARY TRAFFIC SIGNALS (NOT TO SCALE)

08:49:52 02/04/2005

c:\projects\traffic\1013200\1176e\radley.m32

2/4/2005
 c:\projects\traffic\1013200\1176e\radley.m32

TS05

F.A.U. RTE.	SECTION	COUNTY	TOTAL SHEETS	SHEET NO.
1238	2004-125 TS	LAKE	18	7
STA.		TO STA.		
FED. ROAD DIST. NO. 1 ILLINOIS FED. AID PROJECT				
CONTRACT NO. 62890				

IL. ROUTE 176

HERKYS DR.

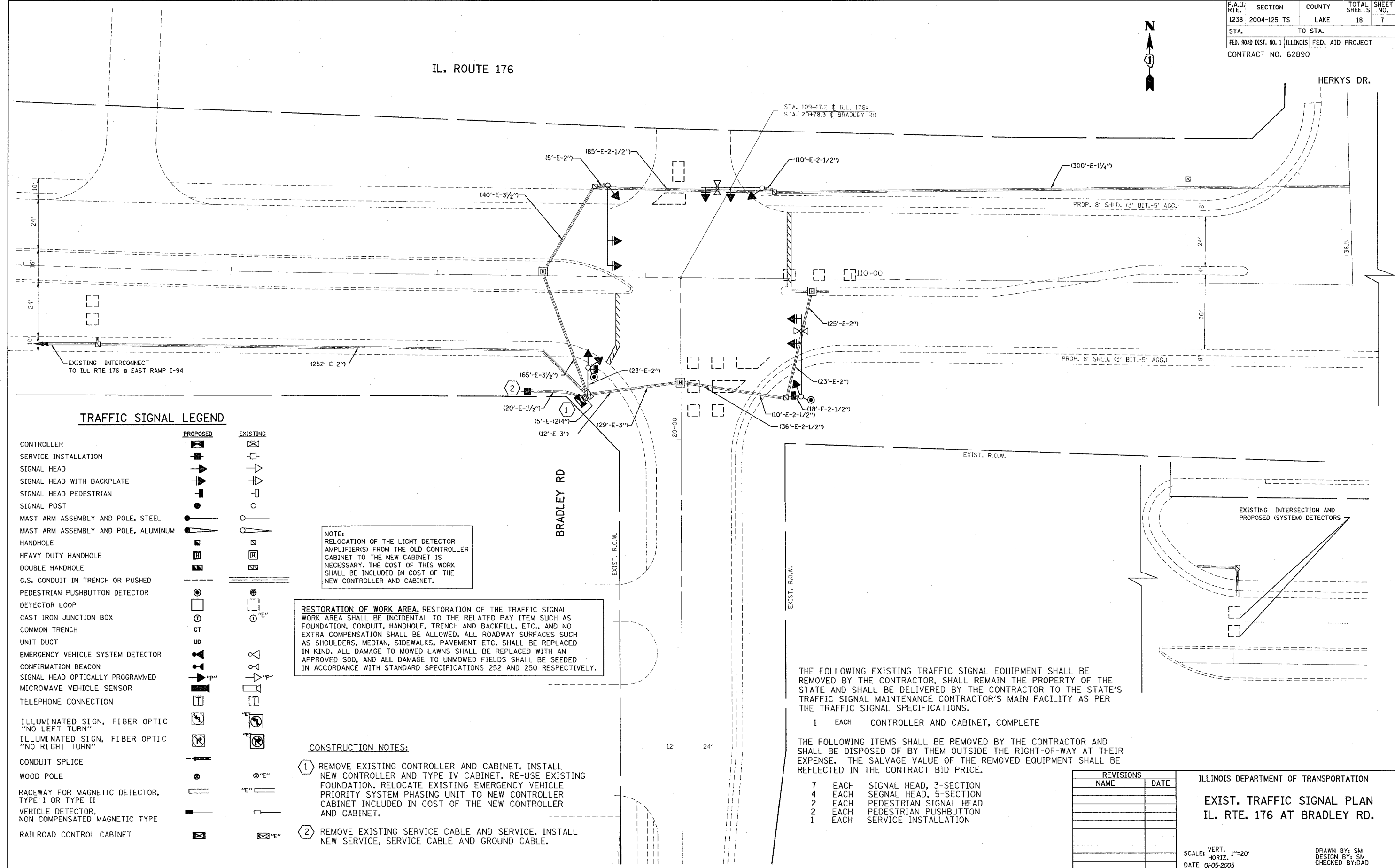

TRAFFIC SIGNAL LEGEND

	PROPOSED	EXISTING
CONTROLLER	[Symbol]	[Symbol]
SERVICE INSTALLATION	[Symbol]	[Symbol]
SIGNAL HEAD	[Symbol]	[Symbol]
SIGNAL HEAD WITH BACKPLATE	[Symbol]	[Symbol]
SIGNAL HEAD PEDESTRIAN	[Symbol]	[Symbol]
SIGNAL POST	[Symbol]	[Symbol]
MAST ARM ASSEMBLY AND POLE, STEEL	[Symbol]	[Symbol]
MAST ARM ASSEMBLY AND POLE, ALUMINUM	[Symbol]	[Symbol]
HANDHOLE	[Symbol]	[Symbol]
HEAVY DUTY HANDHOLE	[Symbol]	[Symbol]
DOUBLE HANDHOLE	[Symbol]	[Symbol]
G.S. CONDUIT IN TRENCH OR PUSHED	[Symbol]	[Symbol]
PEDESTRIAN PUSHBUTTON DETECTOR	[Symbol]	[Symbol]
DETECTOR LOOP	[Symbol]	[Symbol]
CAST IRON JUNCTION BOX	[Symbol]	[Symbol]
COMMON TRENCH	[Symbol]	[Symbol]
UNIT DUCT	[Symbol]	[Symbol]
EMERGENCY VEHICLE SYSTEM DETECTOR	[Symbol]	[Symbol]
CONFIRMATION BEACON	[Symbol]	[Symbol]
SIGNAL HEAD OPTICALLY PROGRAMMED	[Symbol]	[Symbol]
MICROWAVE VEHICLE SENSOR	[Symbol]	[Symbol]
TELEPHONE CONNECTION	[Symbol]	[Symbol]
ILLUMINATED SIGN, FIBER OPTIC "NO LEFT TURN"	[Symbol]	[Symbol]
ILLUMINATED SIGN, FIBER OPTIC "NO RIGHT TURN"	[Symbol]	[Symbol]
CONDUIT SPLICE	[Symbol]	[Symbol]
WOOD POLE	[Symbol]	[Symbol]
RACEWAY FOR MAGNETIC DETECTOR, TYPE I OR TYPE II	[Symbol]	[Symbol]
VEHICLE DETECTOR, NON COMPENSATED MAGNETIC TYPE	[Symbol]	[Symbol]
RAILROAD CONTROL CABINET	[Symbol]	[Symbol]

NOTE:
RELOCATION OF THE LIGHT DETECTOR AMPLIFIER(S) FROM THE OLD CONTROLLER CABINET TO THE NEW CABINET IS NECESSARY. THE COST OF THIS WORK SHALL BE INCLUDED IN COST OF THE NEW CONTROLLER AND CABINET.

RESTORATION OF WORK AREA. RESTORATION OF THE TRAFFIC SIGNAL WORK AREA SHALL BE INCIDENTAL TO THE RELATED PAY ITEM SUCH AS FOUNDATION, CONDUIT, HANDHOLE, TRENCH AND BACKFILL, ETC., AND NO EXTRA COMPENSATION SHALL BE ALLOWED. ALL ROADWAY SURFACES SUCH AS SHOULDERS, MEDIAN, SIDEWALKS, PAVEMENT ETC. SHALL BE REPLACED IN KIND. ALL DAMAGE TO MOWED LAWNS SHALL BE REPLACED WITH AN APPROVED SOD, AND ALL DAMAGE TO UNMOWED FIELDS SHALL BE SEEDED IN ACCORDANCE WITH STANDARD SPECIFICATIONS 252 AND 250 RESPECTIVELY.

CONSTRUCTION NOTES:

- 1 REMOVE EXISTING CONTROLLER AND CABINET. INSTALL NEW CONTROLLER AND TYPE IV CABINET. RE-USE EXISTING FOUNDATION. RELOCATE EXISTING EMERGENCY VEHICLE PRIORITY SYSTEM PHASING UNIT TO NEW CONTROLLER CABINET INCLUDED IN COST OF THE NEW CONTROLLER AND CABINET.
- 2 REMOVE EXISTING SERVICE CABLE AND SERVICE. INSTALL NEW SERVICE, SERVICE CABLE AND GROUND CABLE.

THE FOLLOWING EXISTING TRAFFIC SIGNAL EQUIPMENT SHALL BE REMOVED BY THE CONTRACTOR, SHALL REMAIN THE PROPERTY OF THE STATE AND SHALL BE DELIVERED BY THE CONTRACTOR TO THE STATE'S TRAFFIC SIGNAL MAINTENANCE CONTRACTOR'S MAIN FACILITY AS PER THE TRAFFIC SIGNAL SPECIFICATIONS.

- 1 EACH CONTROLLER AND CABINET, COMPLETE

THE FOLLOWING ITEMS SHALL BE REMOVED BY THE CONTRACTOR AND SHALL BE DISPOSED OF BY THEM OUTSIDE THE RIGHT-OF-WAY AT THEIR EXPENSE. THE SALVAGE VALUE OF THE REMOVED EQUIPMENT SHALL BE REFLECTED IN THE CONTRACT BID PRICE.

- 7 EACH SIGNAL HEAD, 3-SECTION
- 4 EACH SIGNAL HEAD, 5-SECTION
- 2 EACH PEDESTRIAN SIGNAL HEAD
- 2 EACH PEDESTRIAN PUSHBUTTON
- 1 EACH SERVICE INSTALLATION

REVISIONS	
NAME	DATE

ILLINOIS DEPARTMENT OF TRANSPORTATION
EXIST. TRAFFIC SIGNAL PLAN
IL. RTE. 176 AT BRADLEY RD.

SCALE: VERT. 1"=20'
HORIZ. 1"=20'
DATE 01-05-2005

DRAWN BY: SM
DESIGN BY: SM
CHECKED BY: DAD

F.A.M. R.T.E.	SECTION	COUNTY	TOTAL SHEETS	SHEET NO.
1238	2004-125 TS	LAKE	18	8
STA.		TO STA.		
FED. ROAD DIST. NO. ILLINOIS FED. AID PROJECT				
CONTRACT NO. 62890				

CABLE PLAN LEGEND

EXISTING	PROPOSED	DESCRIPTION
		8" (200mm) TRAFFIC SIGNAL SECTION
		12" (300mm) TRAFFIC SIGNAL SECTION
		12" (300mm) PEDESTRIAN SIGNAL SECTION
		12" (300mm) PEDESTRIAN SIGNAL SECTION
		CONTROLLER CABINET
		SERVICE INSTALLATION
		TELEPHONE CONNECTION
		VEHICLE DETECTOR, INDUCTION LOOP
		MAGNETIC DETECTOR
		EMERGENCY VEHICLE LIGHT DETECTOR
		CONFIRMATION BEACON
		PUSHBUTTON DETECTOR
		DENOTES NUMBER OF CONDUCTORS, ALL CABLE NO. 14 EXCEPT AS INDICATED. ALL LOOP DETECTOR CABLE TO BE SHIELDED.
		GROUND CABLE IN CONDUIT NO. 6 SOLID COPPER (GREEN)
		FIBER OPTIC CABLE IN CONDUIT NO. 62.5/125 MM12F SM12F
		SIGNAL FACE WITH BACKPLATE, "P" INDICATES PROGRAMMED HEAD
		RAILROAD CONTROL CABINET
		GROUND ROD AT HANDHOLE (H), DOUBLE HANDHOLE (H), OR CONTROLLER (C).
		GROUND ROD AT POST (P), OR MAST ARM POLE (MA).
		GROUND ROD AT ELECTRIC SERVICE INSTALLATION

CONTROLLER SEQUENCE

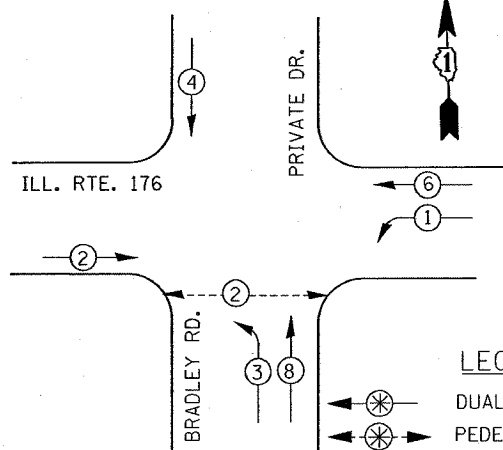

LEGEND

- DUAL ENTRY PHASE
- PEDESTRIAN PHASE
- * NUMBER REFERS TO ASSOCIATED PHASE

PHASE DESIGNATION DIAGRAM

EMERGENCY VEHICLE PREEMPTION DIAGRAM

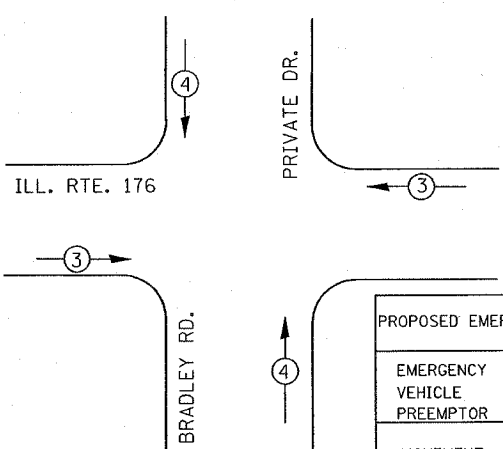

PROPOSED EMERGENCY VEHICLE PREEMPTORS		
EMERGENCY VEHICLE PREEMPTOR	3	4
MOVEMENT		

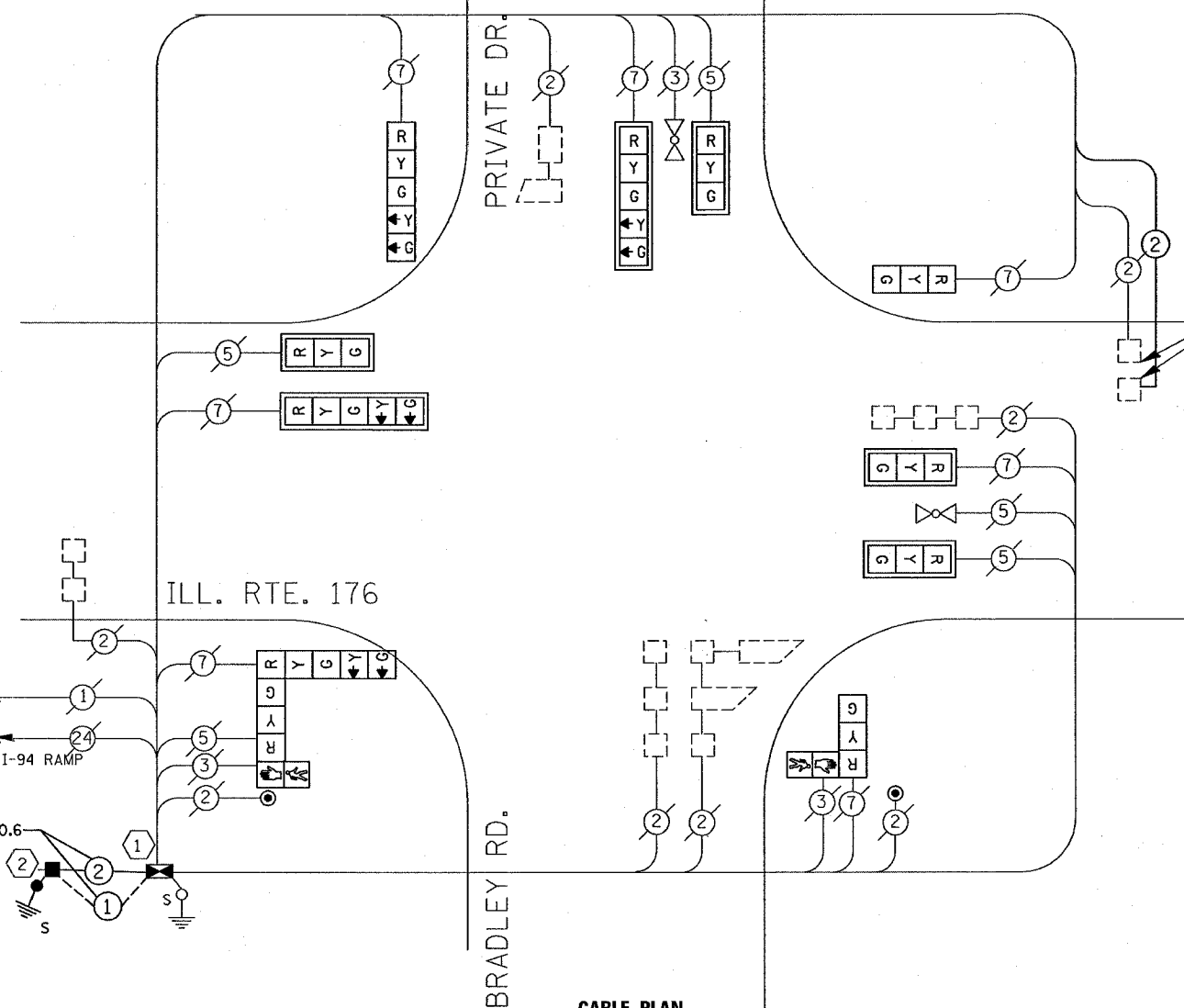

SCHEDULE OF QUANTITIES

QUANTITY	UNIT	ITEM
.2	EACH	TRAFFIC CONTROL AND PROTECTION, STANDARD 701501
.2	EACH	TRAFFIC CONTROL AND PROTECTION, STANDARD 701601
.2	EACH	TRAFFIC CONTROL AND PROTECTION, STANDARD 701701
.2	EACH	TRAFFIC CONTROL AND PROTECTION, STANDARD 701801
1	EACH	MAINTENANCE OF EXISTING TRAFFIC SIGNAL EQUIPMENT
1	EACH	FULL-ACTUATED CONTROLLER AND TYPE IV CABINET (SPECIAL)
1	EACH	TRANSCIEVER-FIBER OPTIC
490	FOOT	ELECTRIC CABLE IN CONDUIT, LEAD-IN, NO.14 1 PAIR
65	FOOT	ELECTRIC CABLE IN CONDUIT, SERVICE, NO.6 2C
6	EACH	INDUCTIVE LOOP DETECTOR
2	EACH	PEDESTRIAN PUSHBUTTON
45	FOOT	REMOVE ELECTRIC CABLE FROM CONDUIT
1	EACH	REMOVE EXISTING TRAFFIC SIGNAL EQUIPMENT
1	EACH	SERVICE INSTALLATION, POLE MOUNTED

QUANTITY	UNIT	ITEM
65	FOOT	ELECTRIC CABLE IN CONDUIT, GROUNDING, NO.6 1C
4	EACH	SIGNAL HEAD, L.E.D., 1-FACE, 3-SECTION MAST ARM MOUNTED
2	EACH	SIGNAL HEAD, L.E.D., 1-FACE, 3-SECTION BRACKET MOUNTED
1	EACH	SIGNAL HEAD, L.E.D., 1-FACE 5-SECTION, BRACKET MOUNTED
2	EACH	SIGNAL HEAD, L.E.D., 1-FACE, 5-SECTION, MAST ARM MOUNTED
1	EACH	SIGNAL HEAD, L.E.D., 2-FACE, 3-SECTION, 5-SECTION, BRACKET MOUNTED
2	EACH	PEDESTRIAN SIGNAL HEAD, 1-FACE, BRACKET MOUNTED
6	EACH	TRAFFIC SIGNAL BACKPLATE, LOUVERED, ALUMINUM

CONSTRUCTION NOTES:

- REMOVE EXISTING CONTROLLER AND CABINET. INSTALL NEW CONTROLLER AND TYPE IV CABINET. RE-USE EXISTING FOUNDATION. RELOCATE EXISTING EMERGENCY VEHICLE PRIORITY SYSTEM PHASING UNIT TO NEW CONTROLLER CABINET INCLUDED IN COST OF THE NEW CONTROLLER AND CABINET.
- REMOVE EXISTING SERVICE CABLE AND SERVICE. INSTALL NEW SERVICE, SERVICE CABLE AND GROUND CABLE.

NOTE: RELOCATION OF THE LIGHT DETECTOR AMPLIFIER(S) FROM THE OLD CONTROLLER CABINET TO THE NEW CABINET IS NECESSARY. THE COST OF THIS WORK SHALL BE INCLUDED IN COST OF THE NEW CONTROLLER AND CABINET.

NOTE: THE PROPOSED TRAFFIC SIGNAL CONTROL EQUIPMENT FOR THIS PROJECT IS "ECONOLITE".

I.D.O.T. TRAFFIC SIGNAL INSTALLATION ELECTRICAL SERVICE REQUIREMENTS					TOTAL WATTAGE
TYPE	NO. LAMPS	WATTAGE INCAND.	LED	% OPERATION	
SIGNAL (RED)	11	135	17	0.50	94
(YELLOW)	11	135	25	0.25	69
(GREEN)	11	135	15	0.25	42
ARROW	8	135	12	0.10	10
PED. SIGNAL	2	90	25	1.00	50
CONTROLLER	1	100	100	1.00	100
ILLUM. SIGN		84		0.05	
FLASHER				0.50	
TOTAL =					365

ENERGY COSTS TO: TOTAL = 365
 ILLINOIS DEPARTMENT OF TRANSPORTATION
 201 WEST CENTER COURT
 SCHAMBURG, ILLINOIS 60196-1096
 ENERGY SUPPLY CONTACT: PAUL CRUZ
 PHONE: 847-816-5331
 COMPANY: COMMONWEALTH EDISON

FOUNDATION (DEPTH)	FT. (m)	CABLE SLACK	FT. (m)	VERTICAL	FT. (m)
TYPE A - POST	4 (1.2)	HANDHOLE	6.5 (2.0)	ALL FOUNDATIONS	3.5 (1.0)
D - CONTROLLER	4 (1.2)	DOUBLE HANDHOLE	13 (4.0)	MAST ARM (L) POLE	20'+L-2'=(6m+L-0.6m)
E - M. ARM POLE		SIGNAL POST	2 (1.0)	BRACKET MOUNTED	13 (4.0)
		24" (600mm)	10 (3.0)	PEDESTRIAN SIGNAL	4 (1.2)
		30" (750mm)	15 (4.6)	ELECTRIC SERVICE	13.5 (4.1)
				SERVICE TO GROUND	13.5 (4.1)
				POST MOUNTED	6 (1.8)

REVISIONS	
NAME	DATE

ILLINOIS DEPARTMENT OF TRANSPORTATION
 CABLE PLAN, PHASE DESIGNATION DIAGRAM, AND SCHEDULE OF QUANTITIES
 ILL RTE 176 @ BRADLEY ROAD
 SCALE: VERT. NONE
 HORIZ. NONE
 DATE 01-05-2005
 DRAWN BY: SM
 DESIGNED BY: SM
 CHECKED BY: DAD

F.A.U. RTE.	SECTION	COUNTY	TOTAL SHEETS	SHEET NO.
1238	2004-125 TS	LAKE	18	9
STA.	TO STA.			
FED. ROAD DIST. NO. 1	ILLINOIS	FED. AID PROJECT		
CONTRACT NO.		62890		

CONSTRUCTION NOTES:

- ① REMOVE EXISTING CONTROLLER AND CABINET. INSTALL NEW CONTROLLER AND TYPE IV CABINET. RE-USE EXISTING FOUNDATION. RELOCATE EXISTING EMERGENCY VEHICLE PRIORITY SYSTEM PHASING UNIT TO NEW CONTROLLER CABINET INCLUDED IN COST OF THE NEW CONTROLLER AND CABINET.
- ② REMOVE EXISTING SERVICE CABLE AND SERVICE. INSTALL NEW SERVICE, SERVICE CABLE AND GROUND CABLE.

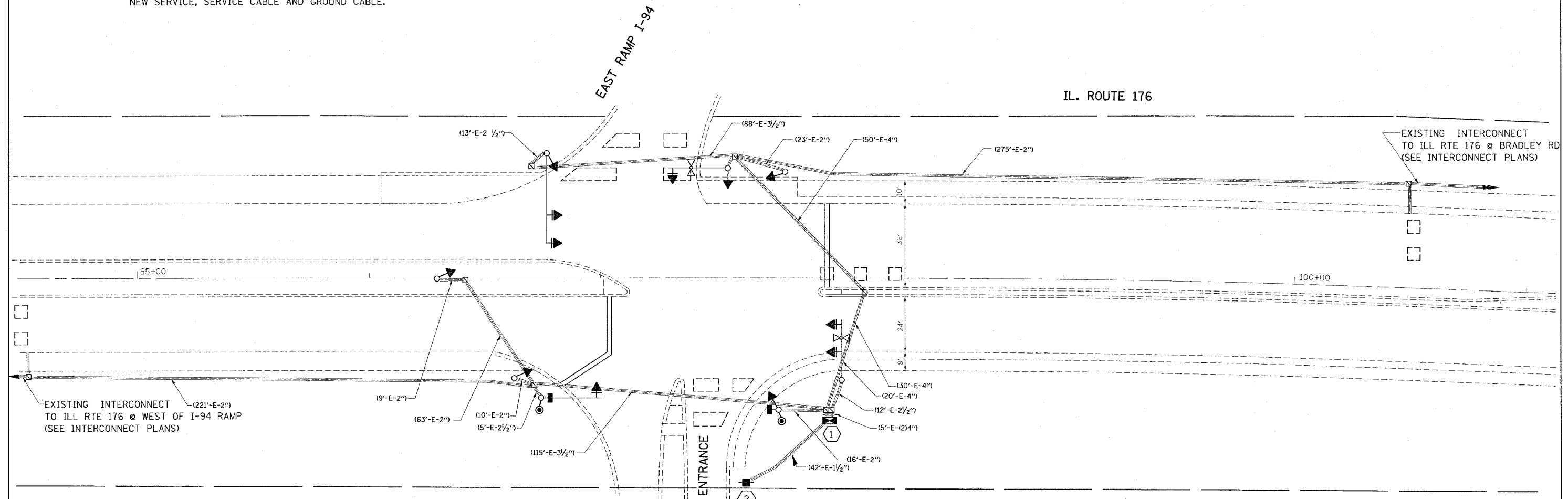

TRAFFIC SIGNAL LEGEND

CONTROLLER			EMERGENCY VEHICLE SYSTEM DETECTOR		
SERVICE INSTALLATION			CONFIRMATION BEACON		
SIGNAL HEAD			SIGNAL HEAD OPTICALLY PROGRAMMED		
SIGNAL HEAD WITH BACKPLATE			MICROWAVE VEHICLE SENSOR		
SIGNAL HEAD PEDESTRIAN			TELEPHONE CONNECTION		
SIGNAL POST			ILLUMINATED SIGN, FIBER OPTIC "NO LEFT TURN"		
MAST ARM ASSEMBLY AND POLE, STEEL			ILLUMINATED SIGN, FIBER OPTIC "NO RIGHT TURN"		
MAST ARM ASSEMBLY AND POLE, ALUMINUM			CONDUIT SPLICE		
HANDHOLE			WOOD POLE		
HEAVY DUTY HANDHOLE			RACEWAY FOR MAGNETIC DETECTOR, TYPE I OR TYPE II		
DOUBLE HANDHOLE			VEHICLE DETECTOR, NON COMPENSATED MAGNETIC TYPE		
G.S. CONDUIT IN TRENCH OR PUSHED			RAILROAD CONTROL CABINET		
PEDESTRIAN PUSHBUTTON DETECTOR					
DETECTOR LOOP					
CAST IRON JUNCTION BOX					
COMMON TRENCH					
UNIT DUCT					

THE FOLLOWING EXISTING TRAFFIC SIGNAL EQUIPMENT SHALL BE REMOVED BY THE CONTRACTOR, SHALL REMAIN THE PROPERTY OF THE STATE AND SHALL BE DELIVERED BY THE CONTRACTOR TO THE STATE'S TRAFFIC SIGNAL MAINTENANCE CONTRACTOR'S MAIN FACILITY AS PER THE TRAFFIC SIGNAL SPECIFICATIONS.

1	EACH	CONTROLLER AND CABINET, COMPLETE
1	EACH	MASTER CONTROLLER

THE FOLLOWING ITEMS SHALL BE REMOVED BY THE CONTRACTOR AND SHALL BE DISPOSED OF BY THEM OUTSIDE THE RIGHT-OF-WAY AT THEIR EXPENSE. THE SALVAGE VALUE OF THE REMOVED EQUIPMENT SHALL BE REFLECTED IN THE CONTRACT BID PRICE.

8	EACH	SIGNAL HEAD, 3-SECTION
2	EACH	SIGNAL HEAD, 4-SECTION
2	EACH	SIGNAL HEAD, 5-SECTION
2	EACH	PEDESTRIAN SIGNAL HEAD
2	EACH	PEDESTRIAN PUSHBUTTON
1	EACH	SERVICE INSTALLATION

RESTORATION OF WORK AREA. RESTORATION OF THE TRAFFIC SIGNAL WORK AREA SHALL BE INCIDENTAL TO THE RELATED PAY ITEM SUCH AS FOUNDATION, CONDUIT, HANDHOLE, TRENCH AND BACKFILL, ETC., AND NO EXTRA COMPENSATION SHALL BE ALLOWED. ALL ROADWAY SURFACES SUCH AS SHOULDERS, MEDIAN, SIDEWALKS, PAVEMENT ETC. SHALL BE REPLACED IN KIND. ALL DAMAGE TO MOWED LAWNS SHALL BE REPLACED WITH AN APPROVED SOD, AND ALL DAMAGE TO UNMOWED FIELDS SHALL BE SEEDED IN ACCORDANCE WITH STANDARD SPECIFICATIONS 252 AND 250 RESPECTIVELY.

REVISIONS	
NAME	DATE

ILLINOIS DEPARTMENT OF TRANSPORTATION
EXIST. TRAFFIC SIGNAL PLAN
IL. RTE. 176 AT EAST OF I-94 RAMP
LAMBS FARM ENTRANCE

SCALE: VERT. 1"=20'
 HORIZ. 1"=20'
 DATE 01-05-2005
 DRAWN BY: SM
 DESIGN BY: SM
 CHECKED BY: DAD

F.A.U. RTE.	SECTION	COUNTY	TOTAL SHEETS	SHEET NO.
1238	2004-125 TS	LAKE	18	10
STA.		TO STA.		
FED. ROAD DIST. NO.		ILLINOIS FED. AID PROJECT		
CONTRACT NO. 62890				

CABLE PLAN LEGEND

EXISTING	PROPOSED	DESCRIPTION
		8" (200mm) TRAFFIC SIGNAL SECTION
		12" (300mm) TRAFFIC SIGNAL SECTION
		12" (300mm) PEDESTRIAN SIGNAL SECTION
		12" (300mm) PEDESTRIAN SIGNAL SECTION
		CONTROLLER CABINET
		SERVICE INSTALLATION
		TELEPHONE CONNECTION
		VEHICLE DETECTOR, INDUCTION LOOP
		MAGNETIC DETECTOR
		EMERGENCY VEHICLE LIGHT DETECTOR
		CONFIRMATION BEACON
		PUSHBUTTON DETECTOR
		DENOTES NUMBER OF CONDUCTORS, ALL CABLE NO. 14 EXCEPT AS INDICATED. ALL LOOP DETECTOR CABLE TO BE SHIELDED.
		GROUND CABLE IN CONDUIT NO. 6 SOLID COPPER (GREEN)
		FIBER OPTIC CABLE IN CONDUIT NO. 62.5/125 MM12F SMI2F
		SIGNAL FACE WITH BACKPLATE, "P" INDICATES PROGRAMMED HEAD
		RAILROAD CONTROL CABINET
		GROUND ROD AT HANDHOLE (H), DOUBLE HANDHOLE (HD), OR CONTROLLER (C).
		GROUND ROD AT POST (P), OR MAST ARM POLE (MA).
		GROUND ROD AT ELECTRIC SERVICE INSTALLATION

CONTROLLER SEQUENCE

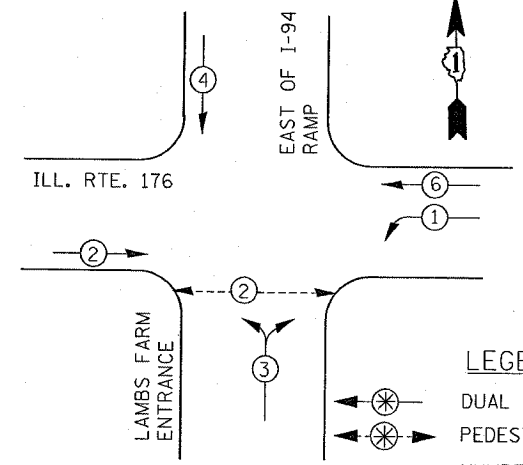

LEGEND
 DUAL ENTRY PHASE
 PEDESTRIAN PHASE
 * NUMBER REFERS TO ASSOCIATED PHASE

PHASE DESIGNATION DIAGRAM

EMERGENCY VEHICLE PREEMPTION DIAGRAM

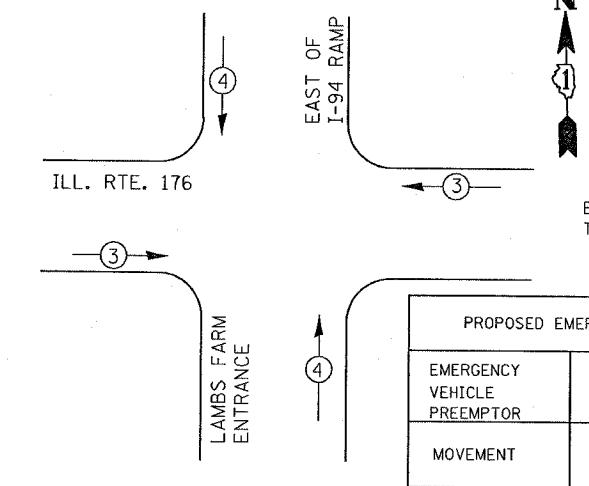

PROPOSED EMERGENCY VEHICLE PREEMPTORS			
EMERGENCY VEHICLE PREEMPTOR	3	4	5
MOVEMENT	← →	↓	↑

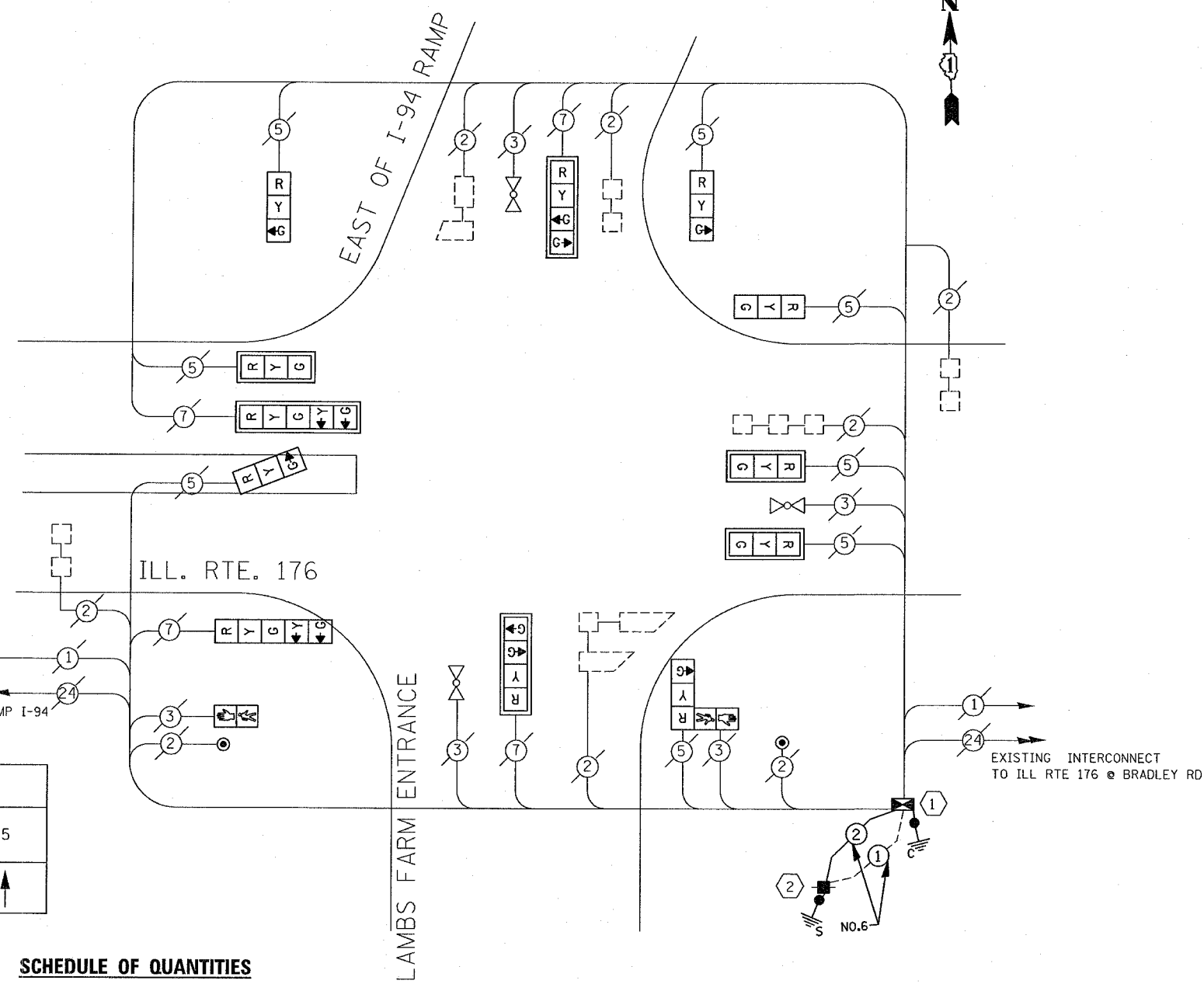

SCHEDULE OF QUANTITIES

QUANTITY	UNIT	ITEM
.2	EACH	TRAFFIC CONTROL AND PROTECTION, STANDARD 701501
.2	EACH	TRAFFIC CONTROL AND PROTECTION, STANDARD 701601
.2	EACH	TRAFFIC CONTROL AND PROTECTION, STANDARD 701701
.2	EACH	TRAFFIC CONTROL AND PROTECTION, STANDARD 701801
1	EACH	MAINTENANCE OF EXISTING TRAFFIC SIGNAL EQUIPMENT
1	EACH	FULL-ACTUATED CONTROLLER AND TYPE IV CABINET (SPECIAL)
1	EACH	TRANSCEIVER-FIBER OPTIC
35	FOOT	ELECTRIC CABLE IN CONDUIT, SERVICE, NO.6 2C
2	EACH	PEDESTRIAN PUSHBUTTON
60	FOOT	REMOVE ELECTRIC CABLE FROM CONDUIT
1	EACH	REMOVE EXISTING TRAFFIC SIGNAL EQUIPMENT
1	EACH	SERVICE INSTALLATION, POLE MOUNTED
35	FOOT	ELECTRIC CABLE IN CONDUIT, GROUNDING, NO.6 1C
3	EACH	SIGNAL HEAD, L.E.D., 1-FACE, 3-SECTION MAST ARM MOUNTED

QUANTITY	UNIT	ITEM
5	EACH	SIGNAL HEAD, L.E.D., 1-FACE, 3-SECTION BRACKET MOUNTED
2	EACH	SIGNAL HEAD, L.E.D., 1-FACE 4-SECTION, MAST ARM MOUNTED
1	EACH	SIGNAL HEAD, L.E.D., 1-FACE 5-SECTION, BRACKET MOUNTED
1	EACH	SIGNAL HEAD, L.E.D., 1-FACE, 5-SECTION, MAST ARM MOUNTED
2	EACH	PEDESTRIAN SIGNAL HEAD, 1-FACE, BRACKET MOUNTED
6	EACH	TRAFFIC SIGNAL BACKPLATE, LOUVERED, ALUMINUM
6	EACH	INDUCTIVE LOOP DETECTOR

CONSTRUCTION NOTES:

- REMOVE EXISTING CONTROLLER AND CABINET. INSTALL NEW CONTROLLER AND TYPE IV CABINET. RE-USE EXISTING FOUNDATION. RELOCATE EXISTING EMERGENCY VEHICLE PRIORITY SYSTEM PHASING UNIT TO NEW CONTROLLER CABINET INCLUDED IN COST OF THE NEW CONTROLLER AND CABINET.
- REMOVE EXISTING SERVICE CABLE AND SERVICE. INSTALL NEW SERVICE, SERVICE CABLE AND GROUND CABLE.

NOTE:
 RELOCATION OF THE LIGHT DETECTOR AMPLIFIER(S) FROM THE OLD CONTROLLER CABINET TO THE NEW CABINET IS NECESSARY. THE COST OF THIS WORK SHALL BE INCLUDED IN COST OF THE NEW CONTROLLER AND CABINET.

NOTE:
 THE PROPOSED TRAFFIC SIGNAL CONTROL EQUIPMENT FOR THIS PROJECT IS "ECONOLITE".

I.D.O.T TRAFFIC SIGNAL INSTALLATION ELECTRICAL SERVICE REQUIREMENTS					TOTAL WATTAGE
TYPE	NO. LAMPS	WATTAGE INCAND.	LED	%OPERATION	
SIGNAL (RED)	12	135	17	0.50	102
(YELLOW)	12	135	25	0.25	75
(GREEN)	6	135	15	0.25	23
ARROW	12	135	12	0.10	15
PED. SIGNAL	2	90	25	1.00	50
CONTROLLER	1	100	100	1.00	100
ILLUM. SIGN		84		0.05	
FLASHER				0.50	
ENERGY COSTS TO:					TOTAL = 365

ILLINOIS DEPARTMENT OF TRANSPORTATION
 201 WEST CENTER COURT
 SCHAUMBURG, ILLINOIS 60196-1096
 ENERGY SUPPLY CONTACT: PAUL CRUZ
 PHONE: 847-816-5331
 COMPANY: COMMONWEALTH EDISON

FOUNDATION (DEPTH)	FT. (m)	CABLE SLACK	FT. (m)	VERTICAL	FT. (m)
TYPE A - POST	4 (1.2)	HANDHOLE	6.5 (2.0)	ALL FOUNDATIONS	3.5 (1.0)
D - CONTROLLER	4 (1.2)	DOUBLE HANDHOLE	13 (4.0)	MAST ARM (L) POLE	20'-H-2=
E - M. ARM POLE		SIGNAL POST	2 (1.0)	(6m+L-0.6m)=	
24" (600mm)	10 (3.0)	CONTROLLER CAB.	1 (0.5)	BRACKET MOUNTED	13 (4.0)
30" (750mm)	15 (4.6)	FIBER OPTIC	13 (4.0)	PED. PUSHBUTTON	4 (1.2)
		ELECTRIC SERVICE	1 (0.5)	ELECTRIC SERVICE	13.5 (4.1)
		GROUND CABLE	1 (0.5)	SERVICE TO GROUND	13.5 (4.1)
				POST MOUNTED	6 (1.8)

REVISIONS	
NAME	DATE

ILLINOIS DEPARTMENT OF TRANSPORTATION
 CABLE PLAN, PHASE DESIGNATION DIAGRAM,
 AND SCHEDULE OF QUANTITIES
 ILL RTE 176 @
 EAST OF I-94 RAMP/LAMBS FARM ENTRANCE
 SCALE: VERT. NONE
 HORIZ. DATE 01-05-2005
 DRAWN BY: SM
 DESIGNED BY: SM
 CHECKED BY: DAD

F.A.U. RTE.	SECTION	COUNTY	TOTAL SHEETS	SHEET NO.
1238	2004-125 TS	LAKE	18	11
STA.		TO STA.		
FED. ROAD DIST. NO. 1		ILLINOIS FED. AID PROJECT		
CONTRACT NO.		62890		



RESTORATION OF WORK AREA. RESTORATION OF THE TRAFFIC SIGNAL WORK AREA SHALL BE INCIDENTAL TO THE RELATED PAY ITEM SUCH AS FOUNDATION, CONDUIT, HANDHOLE, TRENCH AND BACKFILL, ETC., AND NO EXTRA COMPENSATION SHALL BE ALLOWED. ALL ROADWAY SURFACES SUCH AS SHOULDERS, MEDIAN, SIDEWALKS, PAVEMENT ETC. SHALL BE REPLACED IN KIND. ALL DAMAGE TO MOWED LAWNS SHALL BE REPLACED WITH AN APPROVED SOD, AND ALL DAMAGE TO UNMOWED FIELDS SHALL BE SEEDED IN ACCORDANCE WITH STANDARD SPECIFICATIONS 252 AND 250 RESPECTIVELY.

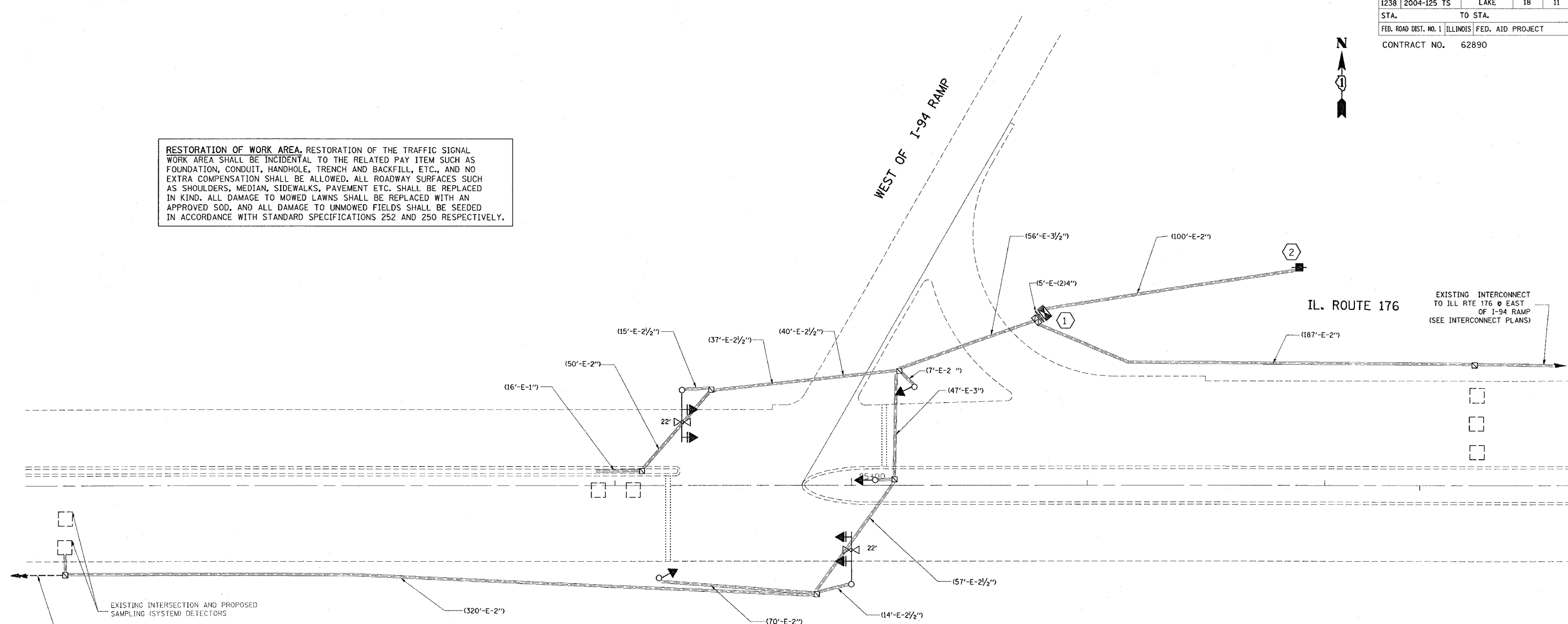

- CONSTRUCTION NOTES:**
- 1 REMOVE EXISTING CONTROLLER AND CABINET. INSTALL NEW CONTROLLER AND TYPE IV CABINET. RE-USE EXISTING FOUNDATION. RELOCATE EXISTING EMERGENCY VEHICLE PRIORITY SYSTEM PHASING UNIT TO NEW CONTROLLER CABINET INCLUDED IN COST OF THE NEW CONTROLLER AND CABINET.
 - 2 REMOVE EXISTING SERVICE CABLE AND SERVICE. INSTALL NEW SERVICE, SERVICE CABLE AND GROUND CABLE.

TRAFFIC SIGNAL LEGEND

CONTROLLER			EMERGENCY VEHICLE SYSTEM DETECTOR		
SERVICE INSTALLATION			CONFIRMATION BEACON		
SIGNAL HEAD			SIGNAL HEAD OPTICALLY PROGRAMMED		
SIGNAL HEAD WITH BACKPLATE			MICROWAVE VEHICLE SENSOR		
SIGNAL HEAD PEDESTRIAN			TELEPHONE CONNECTION		
SIGNAL POST			ILLUMINATED SIGN, FIBER OPTIC "NO LEFT TURN"		
MAST ARM ASSEMBLY AND POLE, STEEL			ILLUMINATED SIGN, FIBER OPTIC "NO RIGHT TURN"		
MAST ARM ASSEMBLY AND POLE, ALUMINUM			CONDUIT SPLICE		
HANDHOLE			WOOD POLE		
HEAVY DUTY HANDHOLE			RACEWAY FOR MAGNETIC DETECTOR, TYPE I OR TYPE II		
DOUBLE HANDHOLE			VEHICLE DETECTOR, NON COMPENSATED MAGNETIC TYPE		
G.S. CONDUIT IN TRENCH OR PUSHED			RAILROAD CONTROL CABINET		
PEDESTRIAN PUSHBUTTON DETECTOR					
DETECTOR LOOP					
CAST IRON JUNCTION BOX					
COMMON TRENCH					
UNIT DUCT					

THE FOLLOWING EXISTING TRAFFIC SIGNAL EQUIPMENT SHALL BE REMOVED BY THE CONTRACTOR, SHALL REMAIN THE PROPERTY OF THE STATE AND SHALL BE DELIVERED BY THE CONTRACTOR TO THE STATE'S TRAFFIC SIGNAL MAINTENANCE CONTRACTOR'S MAIN FACILITY AS PER THE TRAFFIC SIGNAL SPECIFICATIONS.

1 EACH CONTROLLER AND CABINET, COMPLETE

THE FOLLOWING ITEMS SHALL BE REMOVED BY THE CONTRACTOR AND SHALL BE DISPOSED OF BY THEM OUTSIDE THE RIGHT-OF-WAY AT THEIR EXPENSE. THE SALVAGE VALUE OF THE REMOVED EQUIPMENT SHALL BE REFLECTED IN THE CONTRACT BID PRICE.

2 EACH SIGNAL HEAD, 1-SECTION
5 EACH SIGNAL HEAD, 3-SECTION
1 EACH SERVICE INSTALLATION

REVISIONS	
NAME	DATE

ILLINOIS DEPARTMENT OF TRANSPORTATION

EXIST. TRAFFIC SIGNAL PLAN

IL. RTE. 176 AT WEST RAMP I-94

SCALE: VERT. 1"=20'
HORIZ. 1"=20'
DATE 01-05-2005

DRAWN BY: SM
DESIGN BY: SM
CHECKED BY: DAD

F.A.U. RTE.	SECTION	COUNTY	TOTAL SHEETS	SHEET NO.
STA. 2004-125 TS	LAKE	18	12	
STA. TO STA.		ILLINOIS FED. AID PROJECT		
CONTRACT NO. 62890				

CONTROLLER SEQUENCE

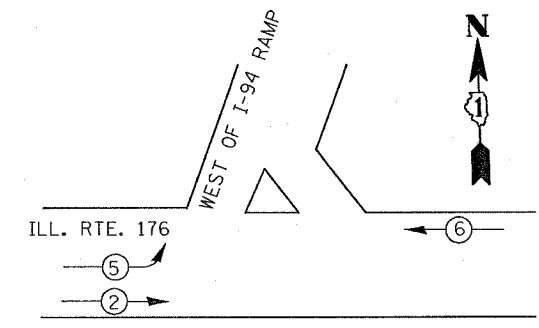

LEGEND

DUAL ENTRY PHASE
 PEDESTRIAN PHASE
 * NUMBER REFERS TO ASSOCIATED PHASE

PHASE DESIGNATION DIAGRAM

EMERGENCY VEHICLE PREEMPTION SEQUENCE

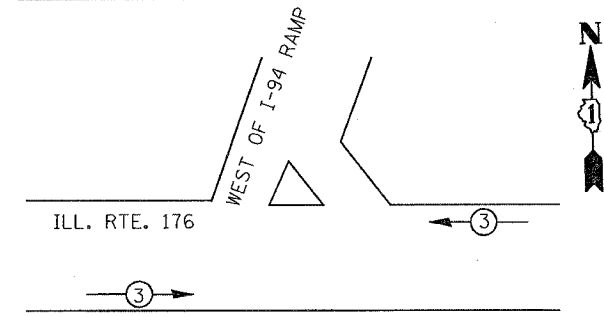

PROPOSED EMERGENCY VEHICLE PREEMPTORS

EMERGENCY VEHICLE PREEMPTOR	3
MOVEMENT	

EXISTING INTERSECTION AND SAMPLING (SYSTEM) DETECTORS

TRACER CABLE
 PROPOSED INTERCONNECT TO ILL.176 @ ST. MARY'S ROAD

CABLE PLAN

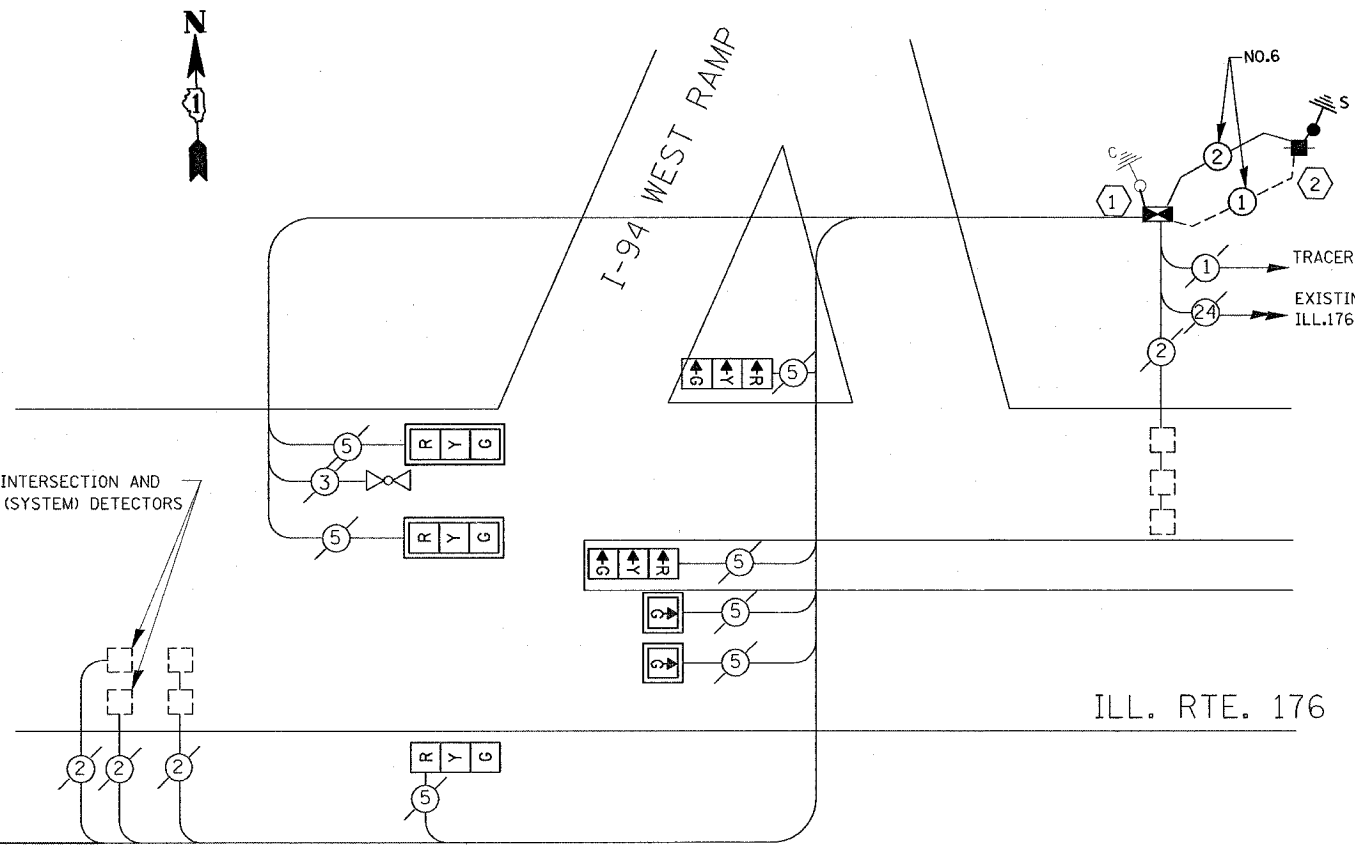

CABLE PLAN LEGEND

- | | | |
|--|--|---|
| | | 8" (200mm) TRAFFIC SIGNAL SECTION |
| | | 12" (300mm) TRAFFIC SIGNAL SECTION |
| | | 12" (300mm) PEDESTRIAN SIGNAL SECTION |
| | | 12" (300mm) PEDESTRIAN SIGNAL SECTION |
| | | CONTROLLER CABINET |
| | | SERVICE INSTALLATION |
| | | TELEPHONE CONNECTION |
| | | VEHICLE DETECTOR, INDUCTION LOOP |
| | | MAGNETIC DETECTOR |
| | | EMERGENCY VEHICLE LIGHT DETECTOR |
| | | CONFIRMATION BEACON |
| | | PUSHBUTTON DETECTOR |
| | | DENOTES NUMBER OF CONDUCTORS. ALL CABLE NO. 14 EXCEPT AS INDICATED. ALL LOOP DETECTOR CABLE TO BE SHIELDED. |
| | | GROUND CABLE IN CONDUIT NO. 6 SOLID COPPER (GREEN) |
| | | FIBER OPTIC CABLE IN CONDUIT NO. 62.5/125 MM12F SM12F |
| | | SIGNAL FACE WITH BACKPLATE, "P" INDICATES PROGRAMMED HEAD |
| | | RAILROAD CONTROL CABINET |
| | | GROUND ROD AT HANDHOLE (H), DOUBLE HANDHOLE (HH), OR CONTROLLER (C). |
| | | GROUND ROD AT POST (P), OR MAST ARM POLE (MA). |
| | | GROUND ROD AT ELECTRIC SERVICE INSTALLATION |

SCHEDULE OF QUANTITIES

QUANTITY	UNIT	ITEM
.2	EACH	TRAFFIC CONTROL AND PROTECTION, STANDARD 701801
.2	EACH	TRAFFIC CONTROL AND PROTECTION, STANDARD 701501
.2	EACH	TRAFFIC CONTROL AND PROTECTION, STANDARD 701601
.2	EACH	TRAFFIC CONTROL AND PROTECTION, STANDARD 701701
1	EACH	MAINTENANCE OF EXISTING TRAFFIC SIGNAL EQUIPMENT
1	EACH	FULL-ACTUATED CONTROLLER AND TYPE IV CABINET(SPECIAL)
1	EACH	TRANSCEIVER-FIBER OPTIC
115	FOOT	ELECTRIC CABLE IN CONDUIT, SERVICE, NO.6 2C
2	EACH	PEDESTRIAN PUSHBUTTON
125	FOOT	REMOVE ELECTRIC CABLE FROM CONDUIT
1	EACH	REMOVE EXISTING TRAFFIC SIGNAL EQUIPMENT
1	EACH	SERVICE INSTALLATION, POLE MOUNT
115	FOOT	ELECTRIC CABLE IN CONDUIT, GROUNDING, NO.6 1C
2	EACH	SIGNAL HEAD, L.E.D., 1-FACE, 3-SECTION MAST ARM MOUNTED

QUANTITY	UNIT	ITEM
3	EACH	SIGNAL HEAD, L.E.D., 1-FACE, 3-SECTION BRACKET MOUNTED
2	EACH	SIGNAL HEAD, L.E.D., 1-FACE, 1-SECTION, MAST ARM MOUNTED
4	EACH	TRAFFIC SIGNAL BACKPLATE, LOUVERED, ALUMINUM
4	EACH	INDUCTIVE LOOP DETECTORS

CONSTRUCTION NOTES:

- REMOVE EXISTING CONTROLLER AND CABINET. INSTALL NEW CONTROLLER AND TYPE IV CABINET. RE-USE EXISTING FOUNDATION. RELOCATE EXISTING EMERGENCY VEHICLE PRIORITY SYSTEM PHASING UNIT TO NEW CONTROLLER CABINET INCLUDED IN COST OF THE NEW CONTROLLER AND CABINET.
- REMOVE EXISTING SERVICE CABLE AND SERVICE. INSTALL NEW SERVICE, SERVICE CABLE AND GROUND CABLE.

NOTE: RELOCATION OF THE LIGHT DETECTOR AMPLIFIER(S) FROM THE OLD CONTROLLER CABINET TO THE NEW CABINET IS NECESSARY. THE COST OF THIS WORK SHALL BE INCLUDED IN COST OF THE NEW CONTROLLER AND CABINET.

NOTE: THE PROPOSED TRAFFIC SIGNAL CONTROL EQUIPMENT FOR THIS PROJECT IS "ECONOLITE".

I.D.O.T. TRAFFIC SIGNAL INSTALLATION ELECTRICAL SERVICE REQUIREMENTS					TOTAL WATTAGE
TYPE	NO. LAMPS	WATTAGE INCAND.	LED	%OPERATION	
SIGNAL (RED)	3	135	17	0.50	26
(YELLOW)	3	135	25	0.25	19
(GREEN)	3	135	15	0.25	12
ARROW	8	135	12	0.10	10
PED. SIGNAL		90	25	1.00	
CONTROLLER	1	100	100	1.00	100.00
ILLUM. SIGN		84		0.05	
FLASHER				0.50	
ENERGY COSTS TO:					TOTAL = 167

ILLINOIS DEPARTMENT OF TRANSPORTATION
 201 WEST CENTER COURT
 SCHAUMBURG, ILLINOIS 60196-1096
 CONTACT: PAUL CRUZ
 PHONE: 847-816-5331
 COMPANY: COMMONWEALTH EDISON

FOUNDATION (DEPTH)	FT. (m)	CABLE SLACK	FT. (m)	VERTICAL	FT. (m)
TYPE A - POST	4 (1.2)	HANDHOLE	6.5 (2.0)	ALL FOUNDATIONS	3.5 (1.0)
D - CONTROLLER	4 (1.2)	DOUBLE HANDHOLE	13 (4.0)	MAST ARM (L) POLE	20'H-2= (6m+L-0.6m)=
E - M. ARM POLE		SIGNAL POST	2 (1.0)	BRACKET MOUNTED	13 (4.0)
24" (600mm)	10 (3.0)	CONTROLLER CAB.	1 (0.5)	PED. PUSHBUTTON	4 (1.2)
30" (750mm)	15 (4.6)	FIBER OPTIC	13 (4.0)	ELECTRIC SERVICE	13.5 (4.1)
		ELECTRIC SERVICE	1 (0.5)	SERVICE TO GROUND	13.5 (4.1)
		GROUND CABLE	1 (0.5)	POST MOUNTED	6 (1.8)

REVISIONS	
NAME	DATE

ILLINOIS DEPARTMENT OF TRANSPORTATION
 CABLE PLAN, PHASE DESIGNATION DIAGRAM, AND SCHEDULE OF QUANTITIES
 ILL RTE 176 @ WEST OF I-94 RAMP
 SCALE: VERT. NONE
 HORIZ. DATE 01-05-2005
 DRAWN BY: SM
 DESIGNED BY: SM
 CHECKED BY: DAD

F.A. RTE.	SECTION	COUNTY	TOTAL SHEETS	SHEET NO.
1238	2004-125 TS	LAKE	18	13
STA.		TO STA.		
FED. ROAD DIST. NO. 1		ILLINOIS	FED. AID PROJECT	
CONTRACT NO. 62890				

TRAFFIC SIGNAL LEGEND

	PROPOSED	EXISTING
CONTROLLER		
SERVICE INSTALLATION		
SIGNAL HEAD		
SIGNAL HEAD WITH BACKPLATE		
SIGNAL HEAD PEDESTRIAN		
SIGNAL POST		
MAST ARM ASSEMBLY AND POLE, STEEL		
MAST ARM ASSEMBLY AND POLE, ALUMINUM		
HANDHOLE		
HEAVY DUTY HANDHOLE		
DOUBLE HANDHOLE		
G.S. CONDUIT IN TRENCH OR PUSHED		
PEDESTRIAN PUSHBUTTON DETECTOR		
DETECTOR LOOP		
CAST IRON JUNCTION BOX		
COMMON TRENCH		
UNIT DUCT		
EMERGENCY VEHICLE SYSTEM DETECTOR		
CONFIRMATION BEACON		
SIGNAL HEAD OPTICALLY PROGRAMMED		
MICROWAVE VEHICLE SENSOR		
TELEPHONE CONNECTION		
ILLUMINATED SIGN, FIBER OPTIC "NO LEFT TURN"		
ILLUMINATED SIGN, FIBER OPTIC "NO RIGHT TURN"		
CONDUIT SPLICE		
WOOD POLE		
RACEWAY FOR MAGNETIC DETECTOR, TYPE I OR TYPE II		
VEHICLE DETECTOR, NON COMPENSATED MAGNETIC TYPE		
RAILROAD CONTROL CABINET		
VIDEO DETECTOR		
VIDEO DETECTOR ZONE		

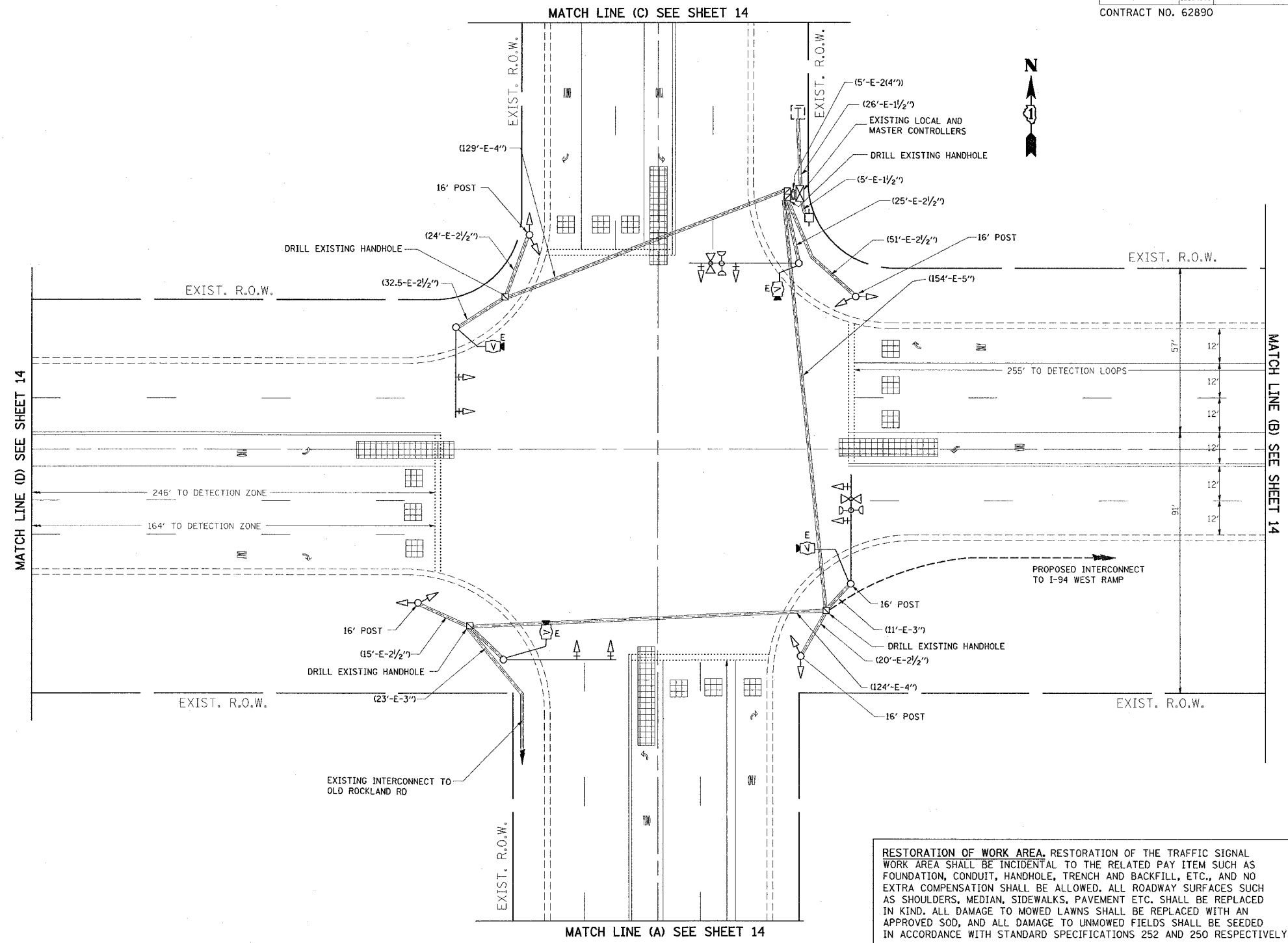

RESTORATION OF WORK AREA, RESTORATION OF THE TRAFFIC SIGNAL WORK AREA SHALL BE INCIDENTAL TO THE RELATED PAY ITEM SUCH AS FOUNDATION, CONDUIT, HANDHOLE, TRENCH AND BACKFILL, ETC., AND NO EXTRA COMPENSATION SHALL BE ALLOWED. ALL ROADWAY SURFACES SUCH AS SHOULDERS, MEDIAN, SIDEWALKS, PAVEMENT ETC. SHALL BE REPLACED IN KIND. ALL DAMAGE TO MOWED LAWNS SHALL BE REPLACED WITH AN APPROVED SOD, AND ALL DAMAGE TO UNMOWED FIELDS SHALL BE SEEDED IN ACCORDANCE WITH STANDARD SPECIFICATIONS 252 AND 250 RESPECTIVELY.

REVISIONS	
NAME	DATE

ILLINOIS DEPARTMENT OF TRANSPORTATION

EXIST. TRAFFIC SIGNAL PLAN

ST. MARY'S ROAD

SCALE: VERT. 1"=20'
HORIZ. 1"=20'

DATE 01-05-2005

DRAWN BY: SM
DESIGN BY: SM
CHECKED BY: DAD

F.A. RTE.	SECTION	COUNTY	TOTAL SHEETS	SHEET NO.
1238	2004-125 TS	LAKE	18	14
STA.		TO STA.		
FED. ROAD DIST. NO. 1		ILLINOIS FED. AID PROJECT		
CONTRACT NO. 62890				

TRAFFIC SIGNAL LEGEND

	PROPOSED	EXISTING
CONTROLLER		
SERVICE INSTALLATION		
SIGNAL HEAD		
SIGNAL HEAD WITH BACKPLATE		
SIGNAL HEAD PEDESTRIAN		
SIGNAL POST		
MAST ARM ASSEMBLY AND POLE, STEEL		
MAST ARM ASSEMBLY AND POLE, ALUMINUM		
HANDHOLE		
HEAVY DUTY HANDHOLE		
DOUBLE HANDHOLE		
G.S. CONDUIT IN TRENCH OR PUSHED		
PEDESTRIAN PUSHBUTTON DETECTOR		
DETECTOR LOOP		
CAST IRON JUNCTION BOX		
COMMON TRENCH		
UNIT DUCT		
EMERGENCY VEHICLE SYSTEM DETECTOR		
CONFIRMATION BEACON		
SIGNAL HEAD OPTICALLY PROGRAMMED		
MICROWAVE VEHICLE SENSOR		
TELEPHONE CONNECTION		
ILLUMINATED SIGN, FIBER OPTIC "NO LEFT TURN"		
ILLUMINATED SIGN, FIBER OPTIC "NO RIGHT TURN"		
CONDUIT SPLICE		
WOOD POLE		
RACEWAY FOR MAGNETIC DETECTOR, TYPE I OR TYPE II		
VEHICLE DETECTOR, NON COMPENSATED MAGNETIC TYPE		
RAILROAD CONTROL CABINET		
VIDEO DETECTOR		
VIDEO DETECTOR ZONE		

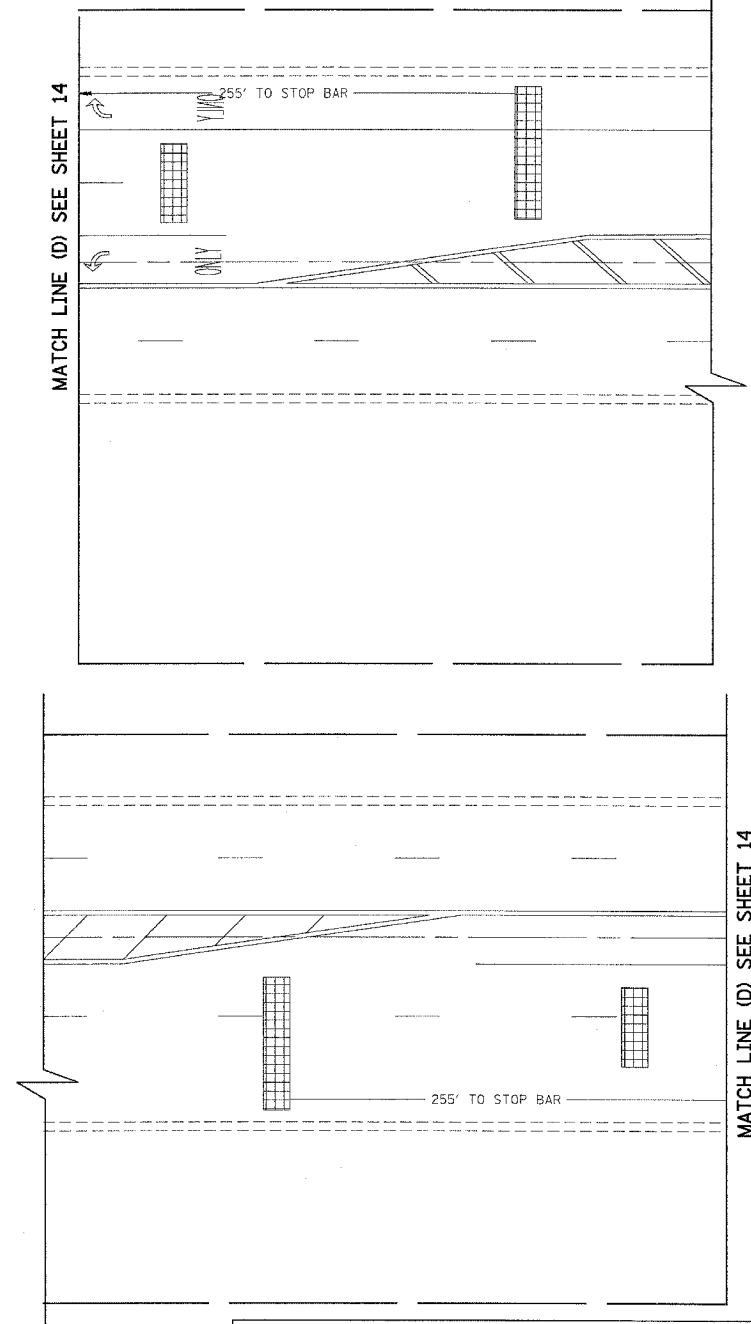
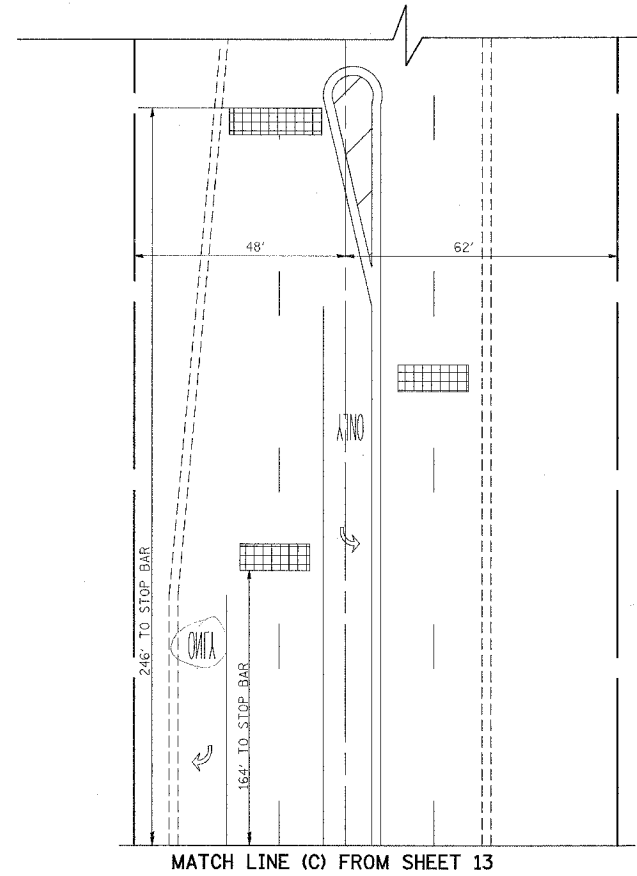
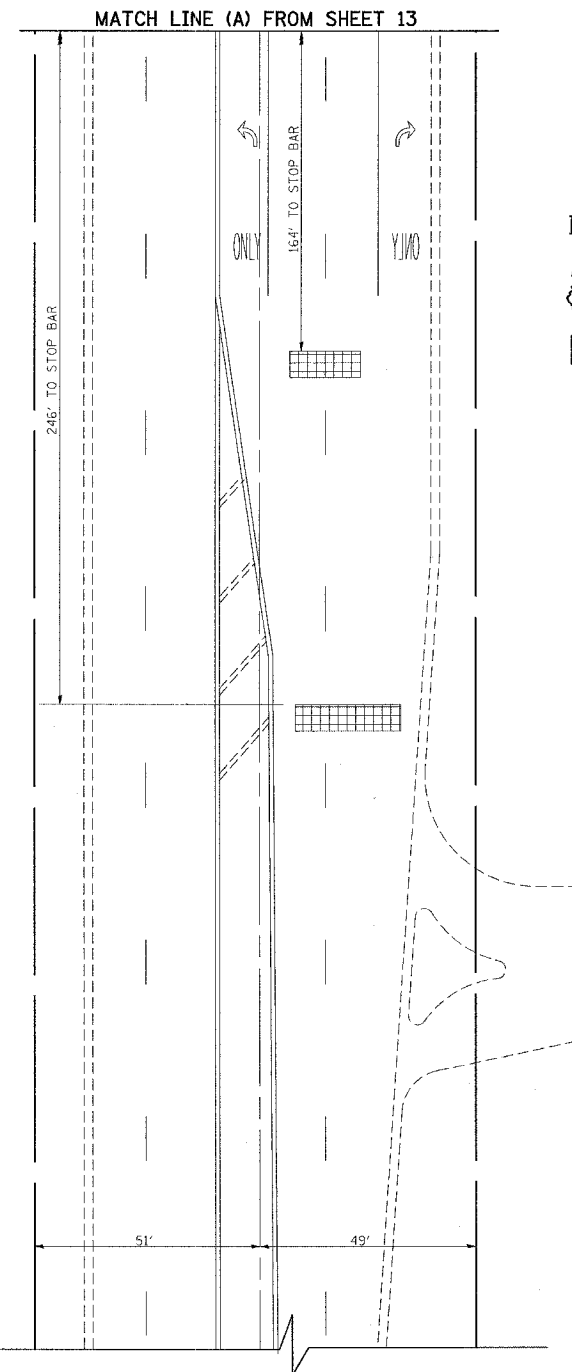

RESTORATION OF WORK AREA, RESTORATION OF THE TRAFFIC SIGNAL WORK AREA SHALL BE INCIDENTAL TO THE RELATED PAY ITEM SUCH AS FOUNDATION, CONDUIT, HANDHOLE, TRENCH AND BACKFILL, ETC., AND NO EXTRA COMPENSATION SHALL BE ALLOWED. ALL ROADWAY SURFACES SUCH AS SHOULDERS, MEDIAN, SIDEWALKS, PAVEMENT ETC. SHALL BE REPLACED IN KIND. ALL DAMAGE TO MOWED LAWNS SHALL BE REPLACED WITH AN APPROVED SOD, AND ALL DAMAGE TO UNMOWED FIELDS SHALL BE SEEDD IN ACCORDANCE WITH STANDARD SPECIFICATIONS 252 AND 250 RESPECTIVELY.

REVISIONS	
NAME	DATE

ILLINOIS DEPARTMENT OF TRANSPORTATION
EXIST. TRAFFIC SIGNAL PLAN
ST. MARY'S ROAD
 SCALE: VERT. 1"=20'
 HORIZ. 1"=20'
 DATE 01-05-2005
 DRAWN BY: SM
 DESIGN BY: SM
 CHECKED BY: DAD

F.A.U. RTE.	SECTION	COUNTY	TOTAL SHEETS	SHEET NO.
1238	2004-125 TS	LAKE	18	15
STA.		TO STA.		
FED. ROAD DIST. NO.		ILLINOIS FED. AID PROJECT		
CONTRACT NO. 62890				

CONTROLLER SEQUENCE

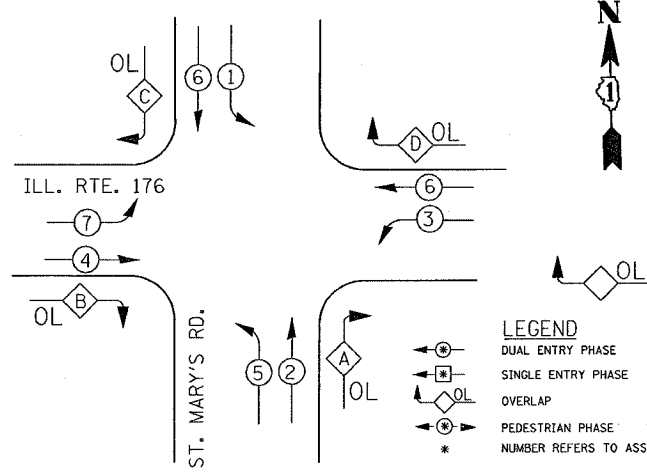

LEGEND
 DUAL ENTRY PHASE
 SINGLE ENTRY PHASE
 OVERLAP
 PEDESTRIAN PHASE
 * NUMBER REFERS TO ASSOCIATED PHASE

PHASE DESIGNATION DIAGRAM

RIGHT TURN OVERLAP PHASE DESIGNATION

OVERLAP LETTER	PERMISSIVE PHASE	PROTECTED PHASE
A	= 2 +	3
B	= 4 +	5
C	= 6 +	7
D	= 8 +	1

EMERGENCY VEHICLE PREEMPTION DIAGRAM

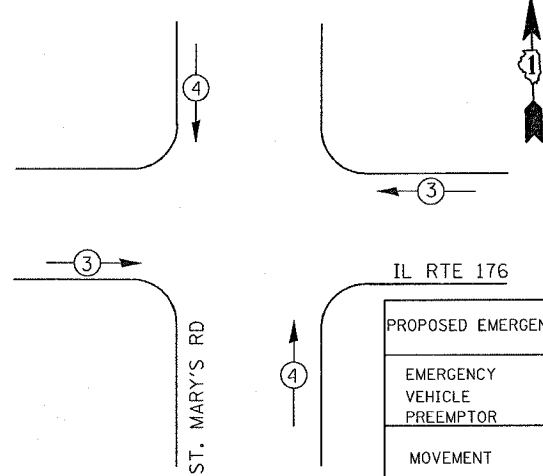

PROPOSED EMERGENCY VEHICLE PREEMPTORS		
EMERGENCY VEHICLE PREEMPTOR	3	4
MOVEMENT	←→	↑↓

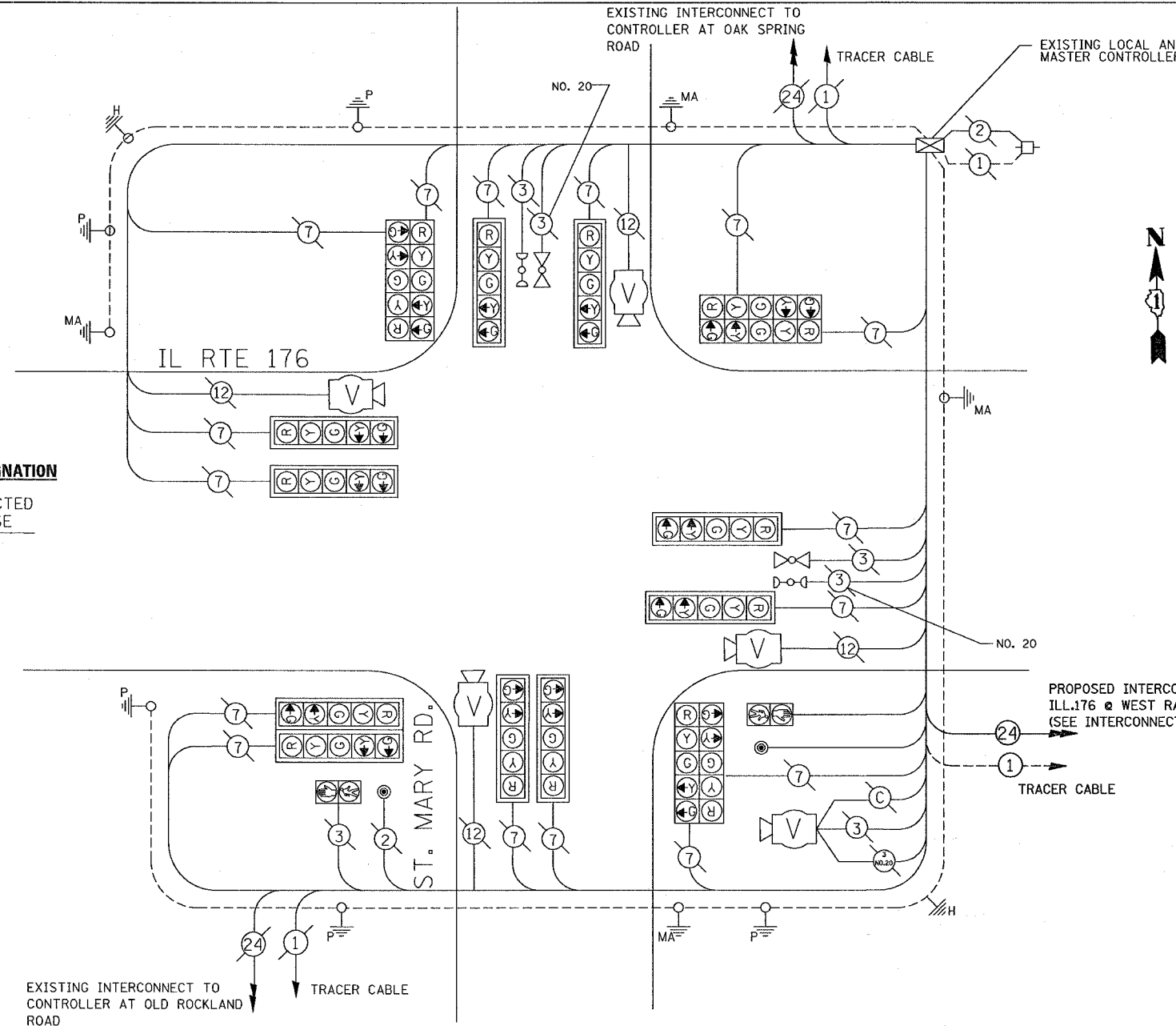

CABLE PLAN LEGEND

- EXISTING: [Symbol] 8" (200mm) TRAFFIC SIGNAL SECTION
- EXISTING: [Symbol] 12" (300mm) TRAFFIC SIGNAL SECTION
- EXISTING: [Symbol] 12" (300mm) PEDESTRIAN SIGNAL SECTION
- EXISTING: [Symbol] 12" (300mm) PEDESTRIAN SIGNAL SECTION
- EXISTING: [Symbol] CONTROLLER CABINET
- EXISTING: [Symbol] SERVICE INSTALLATION
- EXISTING: [Symbol] TELEPHONE CONNECTION
- EXISTING: [Symbol] VEHICLE DETECTOR, INDUCTION LOOP
- EXISTING: [Symbol] MAGNETIC DETECTOR
- EXISTING: [Symbol] EMERGENCY VEHICLE LIGHT DETECTOR
- EXISTING: [Symbol] CONFIRMATION BEACON
- EXISTING: [Symbol] PUSHBUTTON DETECTOR
- EXISTING: [Symbol] DENOTES NUMBER OF CONDUCTORS, ALL CABLE NO. 14 EXCEPT AS INDICATED. ALL LOOP DETECTOR CABLE TO BE SHIELDED.
- EXISTING: [Symbol] GROUND CABLE IN CONDUIT NO. 6 SOLID COPPER (GREEN)
- EXISTING: [Symbol] FIBER OPTIC CABLE IN CONDUIT NO. 62.5/125 MM12F SM12F
- EXISTING: [Symbol] COAXIAL CABLE
- EXISTING: [Symbol] SIGNAL FACE WITH BACKPLATE, "P" INDICATES PROGRAMMED HEAD
- EXISTING: [Symbol] RAILROAD CONTROL CABINET
- EXISTING: [Symbol] GROUND ROD AT HANDHOLE (H), DOUBLE HANDHOLE (H), OR CONTROLLER (C).
- EXISTING: [Symbol] GROUND ROD AT POST (P), OR MAST ARM POLE (MA).
- EXISTING: [Symbol] GROUND ROD AT ELECTRIC SERVICE INSTALLATION
- EXISTING: [Symbol] VIDEO DETECTOR
- PROPOSED: [Symbol] 8" (200mm) TRAFFIC SIGNAL SECTION
- PROPOSED: [Symbol] 12" (300mm) TRAFFIC SIGNAL SECTION
- PROPOSED: [Symbol] 12" (300mm) PEDESTRIAN SIGNAL SECTION
- PROPOSED: [Symbol] 12" (300mm) PEDESTRIAN SIGNAL SECTION
- PROPOSED: [Symbol] CONTROLLER CABINET
- PROPOSED: [Symbol] SERVICE INSTALLATION
- PROPOSED: [Symbol] TELEPHONE CONNECTION
- PROPOSED: [Symbol] VEHICLE DETECTOR, INDUCTION LOOP
- PROPOSED: [Symbol] MAGNETIC DETECTOR
- PROPOSED: [Symbol] EMERGENCY VEHICLE LIGHT DETECTOR
- PROPOSED: [Symbol] CONFIRMATION BEACON
- PROPOSED: [Symbol] PUSHBUTTON DETECTOR
- PROPOSED: [Symbol] DENOTES NUMBER OF CONDUCTORS, ALL CABLE NO. 14 EXCEPT AS INDICATED. ALL LOOP DETECTOR CABLE TO BE SHIELDED.
- PROPOSED: [Symbol] GROUND CABLE IN CONDUIT NO. 6 SOLID COPPER (GREEN)
- PROPOSED: [Symbol] FIBER OPTIC CABLE IN CONDUIT NO. 62.5/125 MM12F SM12F
- PROPOSED: [Symbol] COAXIAL CABLE
- PROPOSED: [Symbol] SIGNAL FACE WITH BACKPLATE, "P" INDICATES PROGRAMMED HEAD
- PROPOSED: [Symbol] RAILROAD CONTROL CABINET
- PROPOSED: [Symbol] GROUND ROD AT HANDHOLE (H), DOUBLE HANDHOLE (H), OR CONTROLLER (C).
- PROPOSED: [Symbol] GROUND ROD AT POST (P), OR MAST ARM POLE (MA).
- PROPOSED: [Symbol] GROUND ROD AT ELECTRIC SERVICE INSTALLATION
- PROPOSED: [Symbol] VIDEO DETECTOR

SCHEDULE OF QUANTITIES

CABLE PLAN

QUANTITY	UNIT	ITEM
.2	EACH	TRAFFIC CONTROL AND PROTECTION, STANDARD 701501
.2	EACH	TRAFFIC CONTROL AND PROTECTION, STANDARD 701601
.2	EACH	TRAFFIC CONTROL AND PROTECTION, STANDARD 701701
.2	EACH	TRAFFIC CONTROL AND PROTECTION, STANDARD 701801
1	EACH	MAINTENANCE OF EXISTING TRAFFIC SIGNAL EQUIPMENT

FOUNDATION (DEPTH)	FT. (m)	CABLE SLACK	FT. (m)	VERTICAL	FT. (m)
TYPE A - POST	4 (1.2)	HANDHOLE	6.5 (2.0)	ALL FOUNDATIONS	3.5 (1.0)
D - CONTROLLER	4 (1.2)	DOUBLE HANDHOLE	13 (4.0)	MAST ARM (L) POLE	20'+L-2=
E - M. ARM POLE	2 (0.6)	SIGNAL POST	2 (1.0)	BRACKET MOUNTED	13 (4.0)
24" (600mm)	10 (3.0)	CONTROLLER CAB.	1 (0.5)	PED. PUSHBUTTON	4 (1.2)
30" (750mm)	15 (4.6)	FIBER OPTIC	13 (4.0)	ELECTRIC SERVICE	13.5 (4.1)
		ELECTRIC SERVICE	1 (0.5)	SERVICE TO GROUND	13.5 (4.1)
		GROUND CABLE	1 (0.5)	POST MOUNTED	6 (1.8)

I.D.O.T TRAFFIC SIGNAL INSTALLATION ELECTRICAL SERVICE REQUIREMENTS					TOTAL WATTAGE
TYPE	NO. LAMPS	WATTAGE INCAND.	LED	%OPERATION	
SIGNAL (RED)	16	135	17	0.50	136
(YELLOW)	16	135	25	0.25	100
(GREEN)	16	135	15	0.25	60
ARROW	32	135	12	0.10	38
PED. SIGNAL	2	90	25	1.00	50
CONTROLLER	1	100	100	1.00	100
ILLUM. SIGN		84		0.05	
FLASHER				0.50	
ENERGY COSTS TO:	TOTAL =				484

ILLINOIS DEPARTMENT OF TRANSPORTATION
 201 WEST CENTER COURT
 SCHAUMBURG, ILLINOIS 60196-1096
 CONTACT: PAUL CRUZ
 PHONE: 847-816-5331
 COMPANY: COMMONWEALTH EDISON

NOTE:
 RELOCATION OF THE LIGHT DETECTOR AMPLIFIER(S) FROM THE OLD CONTROLLER CABINET TO THE NEW CABINET IS NECESSARY. THE COST OF THIS WORK SHALL BE INCLUDED IN COST OF THE NEW CONTROLLER AND CABINET.

REVISIONS	
NAME	DATE

ILLINOIS DEPARTMENT OF TRANSPORTATION
 CABLE PLAN, PHASE DESIGNATION DIAGRAM, AND SCHEDULE OF QUANTITIES
 ILL RTE 176 @ ST. MARY'S ROAD
 SCALE: VERT. NONE
 HORIZ. DATE 01-05-2005
 DRAWN BY: JSM
 DESIGNED BY: SM
 CHECKED BY: DAD

NOTE:
 THE PROPOSED TRAFFIC SIGNAL CONTROL EQUIPMENT FOR THIS PROJECT IS "ECONOLITE".

F.A.U. RTE.	SECTION	COUNTY	TOTAL SHEETS	SHEET NO.
1238	2004-125 TS	LAKE	18	16
STA.		TO STA.		
FED. ROAD DIST. NO. 1		ILLINOIS FED. AID PROJECT		
CONTRACT NO. 62890				

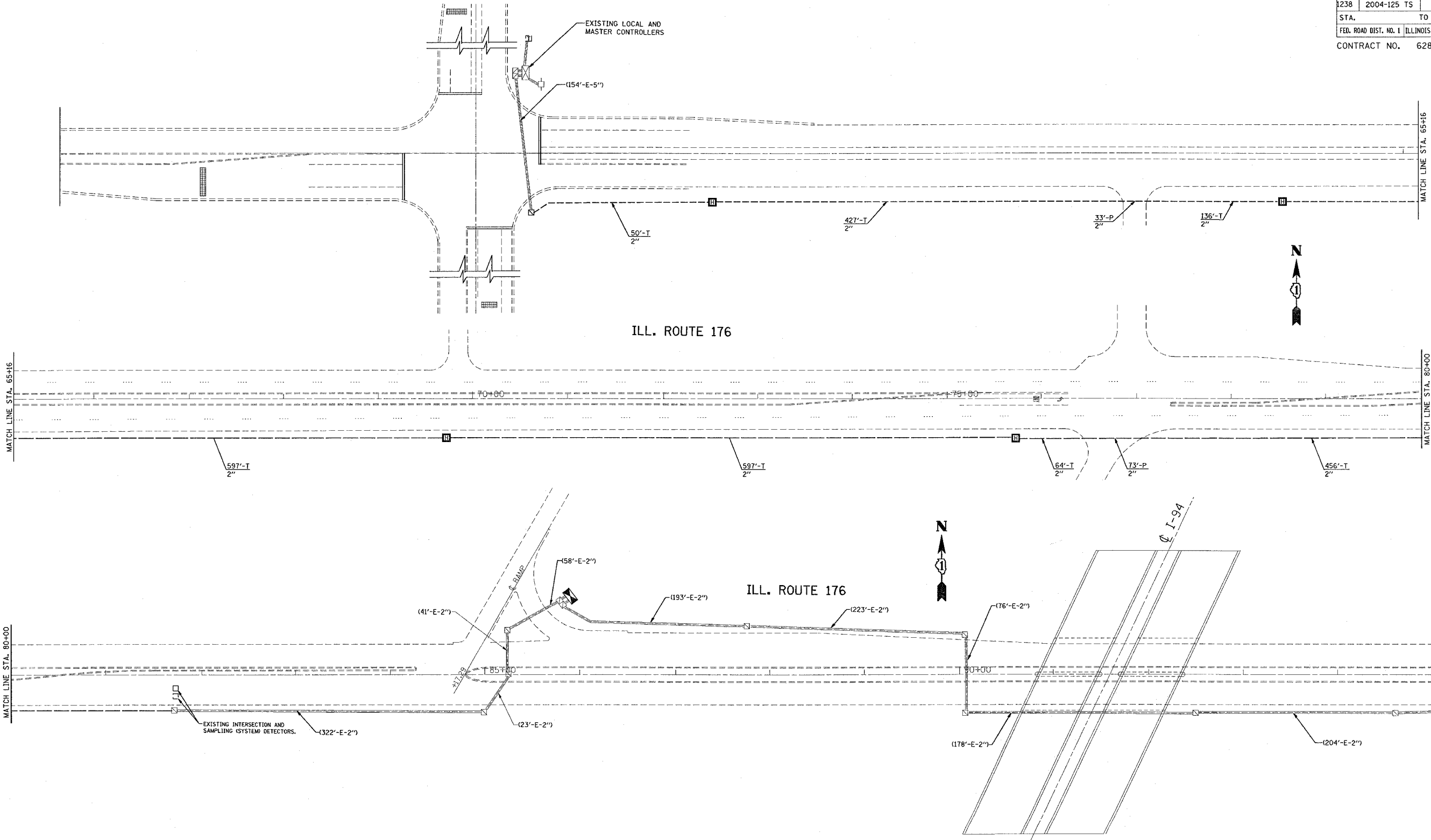

PROPOSED	EXISTING	PROPOSED	EXISTING
		S	I
		IP	I
		UD	
		CT	

RESTORATION OF WORK AREA. RESTORATION OF THE TRAFFIC SIGNAL WORK AREA SHALL BE INCIDENTAL TO THE RELATED PAY ITEM SUCH AS FOUNDATION, CONDUIT, HANDHOLE, TRENCH AND BACKFILL, ETC., AND NO EXTRA COMPENSATION SHALL BE ALLOWED. ALL ROADWAY SURFACES SUCH AS SHOULDERS, MEDIAN, SIDEWALKS, PAVEMENT ETC. SHALL BE REPLACED IN KIND. ALL DAMAGE TO MOWED LAWNS SHALL BE REPLACED WITH AN APPROVED SOD, AND ALL DAMAGE TO UNMOWED FIELDS SHALL BE SEEDED IN ACCORDANCE WITH STANDARD SPECIFICATIONS 252 AND 250 RESPECTIVELY.

REVISIONS	
NAME	DATE

ILLINOIS DEPARTMENT OF TRANSPORTATION
INTERCONNECT PLAN
IL. ROUTE 176
ST. MARY'S RD TO BRADLEY RD

SCALE: 1"=50'
DATE 01-05-2005

DRAWN BY: SM
DESIGN BY: SM
CHECKED BY: DAD

F.A.U. RTE.	SECTION	COUNTY	TOTAL SHEETS	SHEET NO.
1238	2004-125 TS	LAKE	18	17
STA.		TO STA.		
FED. ROAD DIST. NO. 1		ILLINOIS FED. AID PROJECT		
CONTRACT NO.		62890		

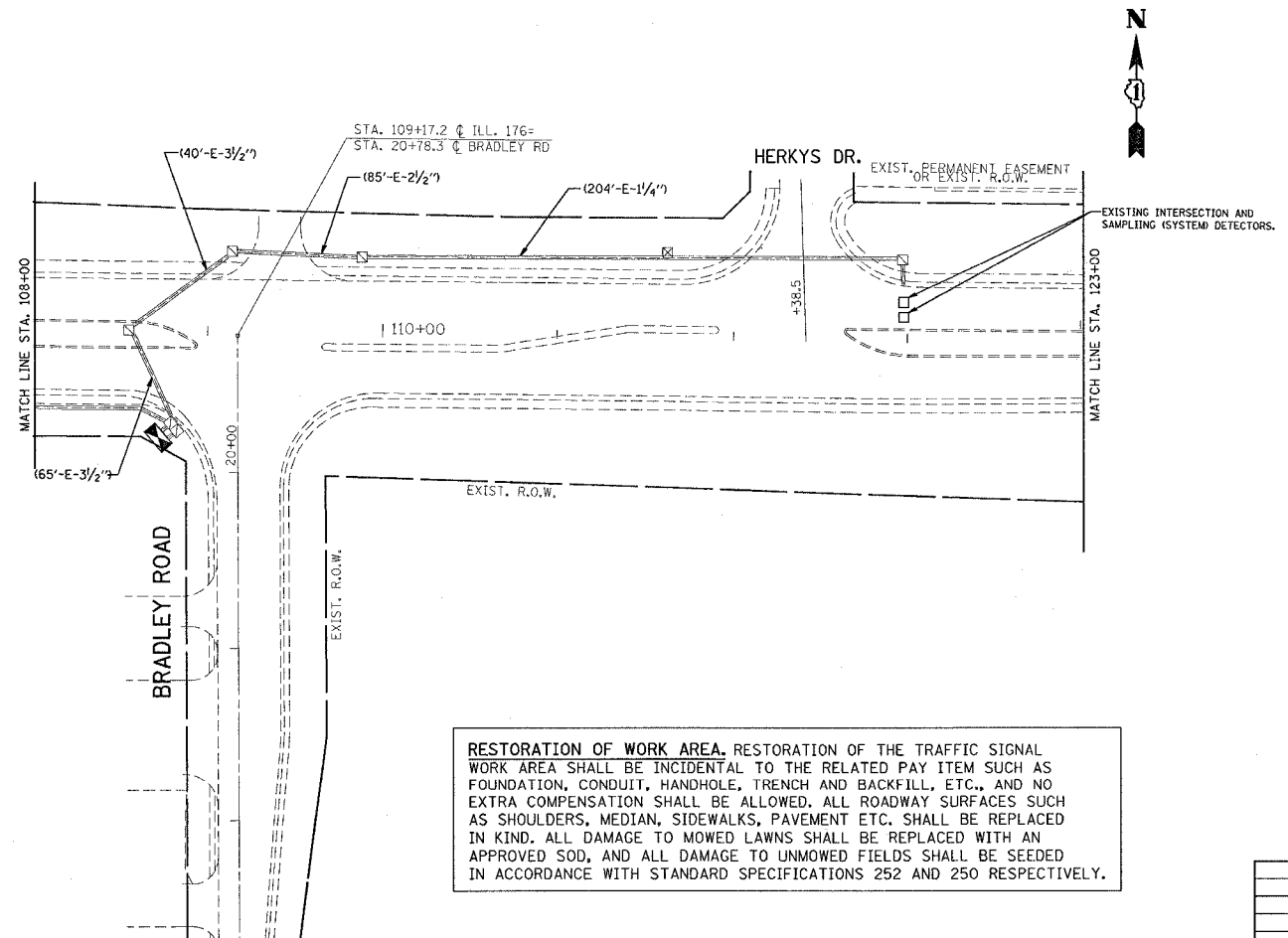
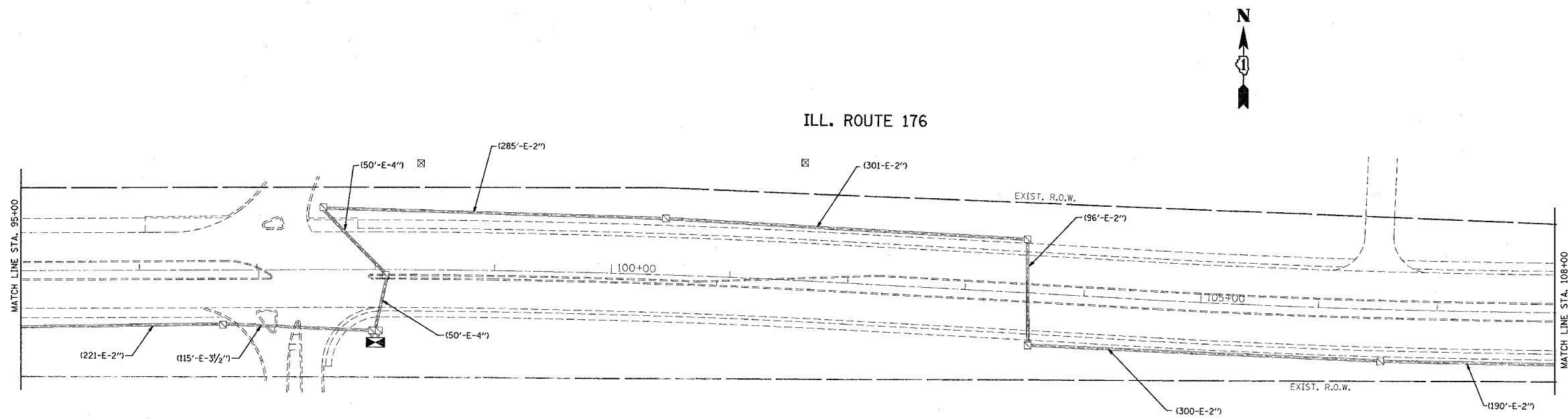

PROPOSED	EXISTING	PROPOSED	EXISTING
		S	I
		IP	
		UD	
		CT	

RESTORATION OF WORK AREA. RESTORATION OF THE TRAFFIC SIGNAL WORK AREA SHALL BE INCIDENTAL TO THE RELATED PAY ITEM SUCH AS FOUNDATION, CONDUIT, HANDHOLE, TRENCH AND BACKFILL, ETC., AND NO EXTRA COMPENSATION SHALL BE ALLOWED. ALL ROADWAY SURFACES SUCH AS SHOULDERS, MEDIAN, SIDEWALKS, PAVEMENT ETC. SHALL BE REPLACED IN KIND. ALL DAMAGE TO MOWED LAWNS SHALL BE REPLACED WITH AN APPROVED SOD, AND ALL DAMAGE TO UNMOWED FIELDS SHALL BE SEEDED IN ACCORDANCE WITH STANDARD SPECIFICATIONS 252 AND 250 RESPECTIVELY.

REVISIONS	
NAME	DATE

ILLINOIS DEPARTMENT OF TRANSPORTATION
INTERCONNECT PLAN
ILL. ROUTE 176
ST. MARY'S RD TO BRADLEY RD
 SCALE: VERT. 1"=50'
 HORIZ. 1"=50'
 DATE 01-05-2005
 DRAWN BY: SM
 CHECKED BY:

F.A.U. RTE.	SECTION	COUNTY	TOTAL SHEETS	N.
1238	2004-125 TS	LAKE	18	18
STA.	TO STA.			
FED. ROAD DIST. NO.	ILLINOIS	FED. AID PROJECT		
CONTRACT NO. 62890				

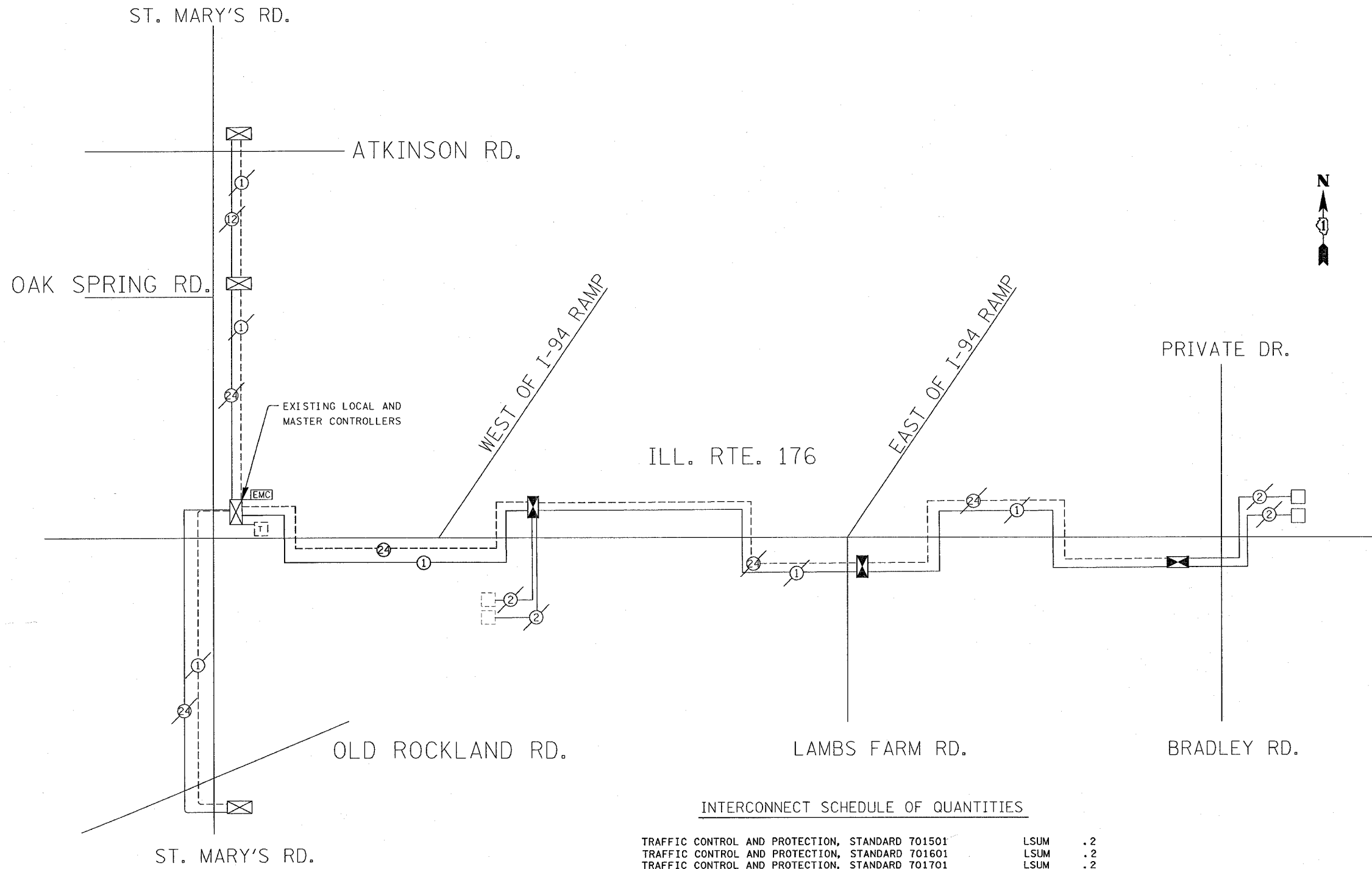

INTERCONNECT SCHEMATIC LEGEND

- EXISTING INTERSECTION CONTROLLER ☒
- PROPOSED INTERSECTION CONTROLLER ☒
- EXISTING MASTER CONTROLLER EMC
- PROPOSED MASTER CONTROLLER MC
- MASTER MASTER CONTROLLER MMC
- EXISTING INTERSECTION & SAMPLING (SYSTEM) DETECTORS ☐
- PROPOSED INTERSECTION & SAMPLING (SYSTEM) DETECTORS ☐
- EXISTING INTERSECTION LOOP DETECTORS P
- PROPOSED SAMPLING (SYSTEM) DETECTORS P
- EXISTING SAMPLING (SYSTEM) DETECTORS ES
- PROPOSED SAMPLING (SYSTEM) DETECTORS PS
- EXISTING SAMPLING (SYSTEM) DETECTORS, PROPOSED INTERSECTION AND SAMPLING (SYSTEM) DETECTORS. ESP
- EXISTING SAMPLING (SYSTEM) DETECTORS, PROPOSED SAMPLING (SYSTEM) DETECTORS. ESPS
- EXISTING PREFORMED INTERSECTION & SAMPLING (SYSTEM) DETECTORS PDI
- PROPOSED PREFORMED INTERSECTION & SAMPLING (SYSTEM) DETECTORS PD
- EXISTING SAMPLING (SYSTEM) PREFORMED DETECTORS ESPD
- PROPOSED SAMPLING (SYSTEM) PREFORMED DETECTORS PSPD
- EXISTING FIBER OPTIC CABLE IN CONDUIT, NO. 62.5/125, MM12F SM12F 24
- PROPOSED FIBER OPTIC CABLE IN CONDUIT, NO. 62.5/125, MM12F SM12F 24
- EXISTING INTERCONNECT CABLE - NO. 62.5/125 12F FIBER OPTIC CABLE 12
- PROPOSED INTERCONNECT CABLE - NO. 62.5/125 12F FIBER OPTIC CABLE 12
- EXISTING INTERCONNECT CABLE - NO. 18 3 PAIR TWISTED, SHIELDED 6
- PROPOSED INTERCONNECT CABLE - NO. 18 3 PAIR TWISTED, SHIELDED 6
- EXISTING LOOP DETECTOR CABLE 2/C TWISTED, SHIELDED 2
- PROPOSED LOOP DETECTOR CABLE 2/C TWISTED, SHIELDED 2
- EXISTING ELECTRIC CABLE, 1/C (AS SPECIFIED) 1
- PROPOSED ELECTRIC CABLE, 1/C (AS SPECIFIED) 1
- EXISTING TELEPHONE CONNECTION T
- PROPOSED TELEPHONE CONNECTION T

INTERCONNECT SCHEDULE OF QUANTITIES

TRAFFIC CONTROL AND PROTECTION, STANDARD 701501	LSUM	.2
TRAFFIC CONTROL AND PROTECTION, STANDARD 701601	LSUM	.2
TRAFFIC CONTROL AND PROTECTION, STANDARD 701701	LSUM	.2
TRAFFIC CONTROL AND PROTECTION, STANDARD 701801	LSUM	.2
CONDUIT IN TRENCH, 2" DIA. GALVANIZED STEEL	FOOT	2380
CONDUIT IN PUSHED, 2" DIA. GALVANIZED STEEL	FOOT	120
HEAVY-HANDHOLE	EACH	4
TRENCH AND BACK FILL FOR ELECTRICAL WORK	FOOT	2380
DRILL EXISTING HANDHOLES	EACH	2
FIBER OPTIC CABLE IN CONDUIT, NO. 62.5/125, MM12F SM12F	FOOT	3230
ELECTRIC CABLE IN CONDUIT TRACER NO. 14 1C	FOOT	3230

REVISIONS	
NAME	DATE

ILLINOIS DEPARTMENT OF TRANSPORTATION

**ILL. RTE. 176
ST. MARY'S RD TO BRADLEY RD.
INTERCONNECT SCHEMATIC**

SCALE: NONE
DATE: 01-05-2005

DRAWN BY: SM
DESIGNED BY: SM
CHECKED BY: DAD

1 4310/13# 06/05/4000