

F.A.I. RTE.	SECTION	COUNTY	TOTAL SHEETS	SHEET NO.
74	*	TAZEWELL	1366	59
STA.		TO STA.		
FED. ROAD DIST. NO.		ILLINOIS FED. AID PROJECT		
* (90-III-R-2); 90(13,14)-IR-1				

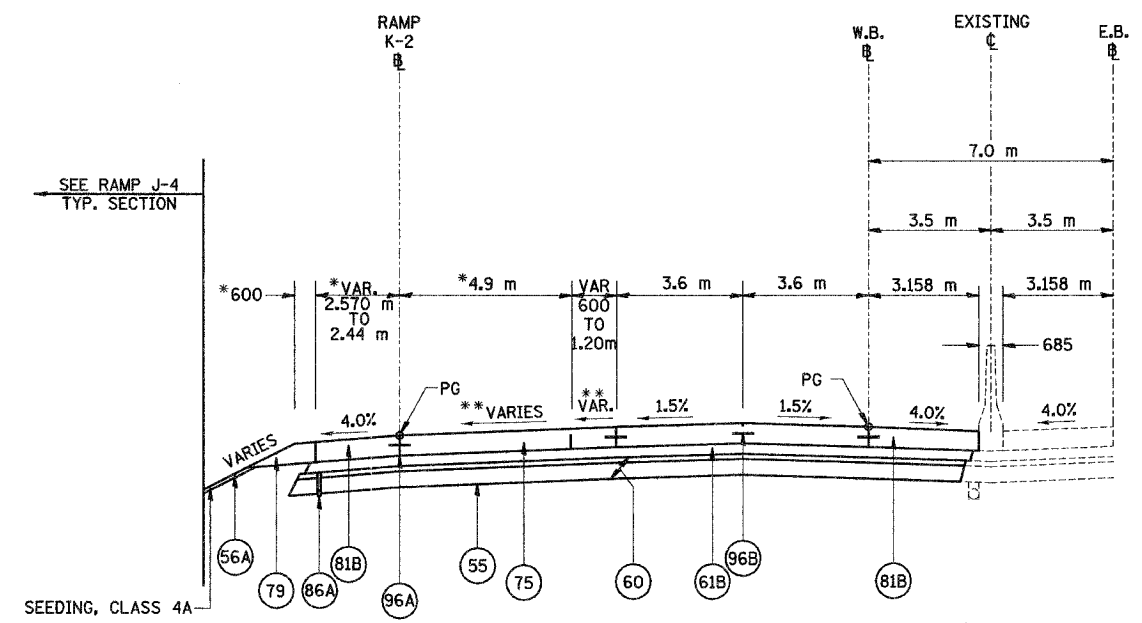

TYPICAL SECTION NO. 6
 STA. 152+835.061 TO STA. 152+865.043 WB (6)

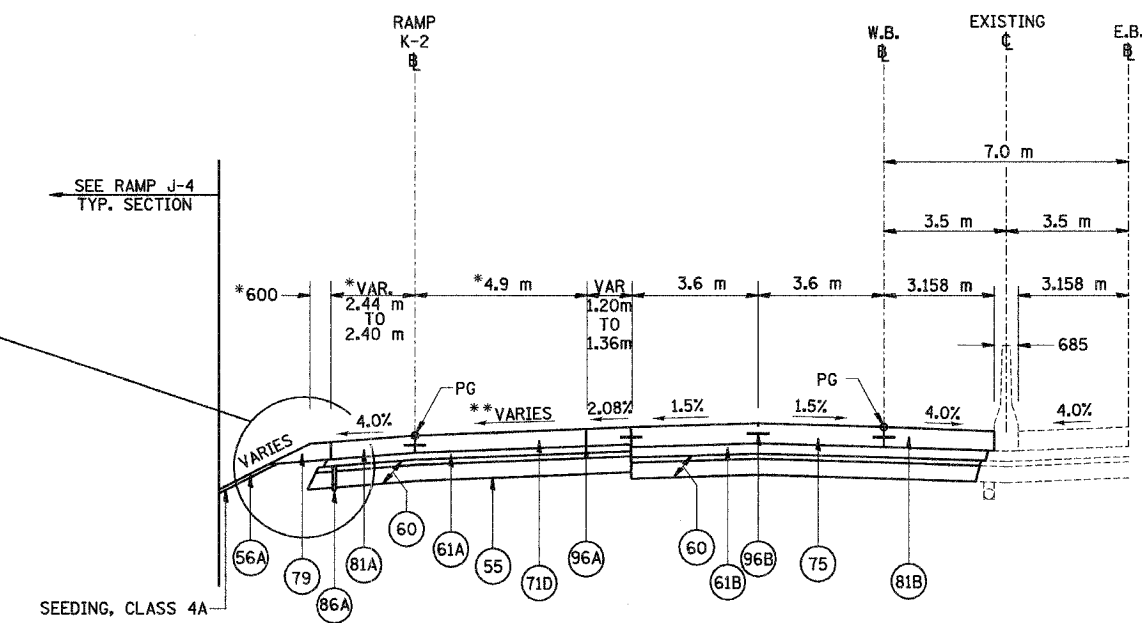

TYPICAL SECTION NO. 7
 STA. 152+865.043 TO STA. 152+873.239 WB (7)

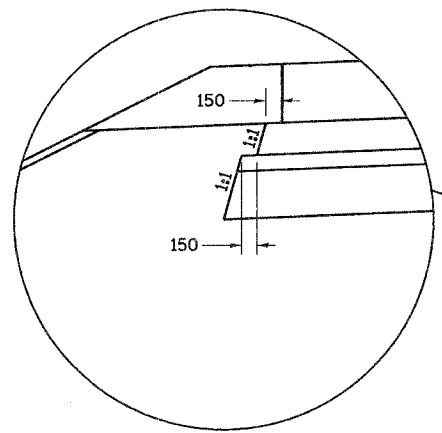

TYPICAL SUB-BASE DETAIL
 (TO SHOW DIMENSIONS ONLY)

*AT RIGHT ANGLES TO RAMP K-2
 ** SEE RAMP GORE & PAVEMENT JOINT DETAIL SHEET

LEGEND		
(55) PR GEOTECHNICAL FABRIC FOR GROUND STABILIZATION	(81A) PR PORTLAND CEMENT CONCRETE SHOULDERS 250 MM	(89K) PR COMB. CONCRETE C&G, TYPE B-15.45
(56A) PR FURNISH AND PLACE TOPSOIL, 100 MM	(81B) PR PORTLAND CEMENT CONCRETE SHOULDERS, 290 MM	(96A) PR LONGITUDINAL CONSTRUCTION JOINT (TYPICAL)
(60) PR AGGREGATE SUB-BASE, 300 MM	(82) PR RETAINING WALL (SEE WALL PLANS)	(96B) PR SAWED LONGITUDINAL JOINT (TYPICAL)
(61A) PR BITUMINOUS CONCRETE BINDER COURSE, SUPERPAVE, IL-19.0L (LOW ESAL), 100MM	(86A) PR PIPE UNDERDRAINS, 100 MM	
(61B) PR BITUMINOUS CONCRETE BINDER COURSE, SUPERPAVE, IL-19.0L (LOW ESAL), 150MM	(86B) PR PIPE UNDERDRAINS, 150 MM	
(71D) PR PORTLAND CEMENT CONCRETE PAVEMENT 250MM (JOINTED)	(88) PR CONCRETE GUTTER, TYPE A (MODIFIED)	
(75) PR CONTINUOUSLY REINFORCED PORTLAND CEMENT CONCRETE PAVEMENT, 290 MM	(89B) PR COMB. CONCRETE C&G, TYPE B-15.60	
(79) PR AGGREGATE SHOULDERS, TYPE B		

NOTES:
 SHOULDERS ADJACENT TO THE HIGH SIDE OF SUPERELEVATED PAVEMENT SHALL BE 4% OR 8% MINUS THE RATE OF SUPER, WHICHEVER IS LESS. ADJACENT TO THE LOW SIDE OF SUPERELEVATED PAVEMENT SHOULDERS SHALL HAVE A SLOPE OF 4% OR THE RATE OF SUPER, WHICHEVER IS GREATER.
 ALL DIMENSIONS ARE IN MILLIMETERS (mm) UNLESS OTHERWISE STATED.
 (60) IS SHOWN IN TWO LAYERS TO DENOTE THE TWO GRADATIONS THAT MAKE UP THIS PAY ITEM.

REVISIONS	
NAME	DATE

ILLINOIS DEPARTMENT OF TRANSPORTATION
 FAI ROUTE 74 (I-74)
PROPOSED TYPICAL SECTIONS
 FAI ROUTE 74 (I-74) (WB)
 NUMBERS 6 & 7
 DRAWN BY DER
 CHECKED BY MLB
 DATE 12-20-04



I:\projects\68201\68201.dwg 12/21/04 10:11:11 AM