

STATE OF ILLINOIS
DEPARTMENT OF TRANSPORTATION

ROUTE NO. F.A.I. 74	SECTION (90-14HB)BR	COUNTY TAZEWELL	TOTAL SHEETS 1366	SHEET NO. 530
FED. ROAD DIST. NO. 7		ILLINOIS	FED. AID PROJECT	

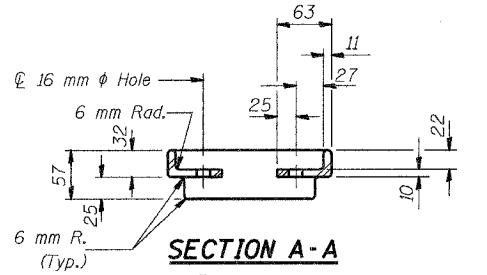

SECTION A-A

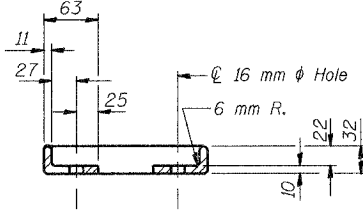

SECTION B-B

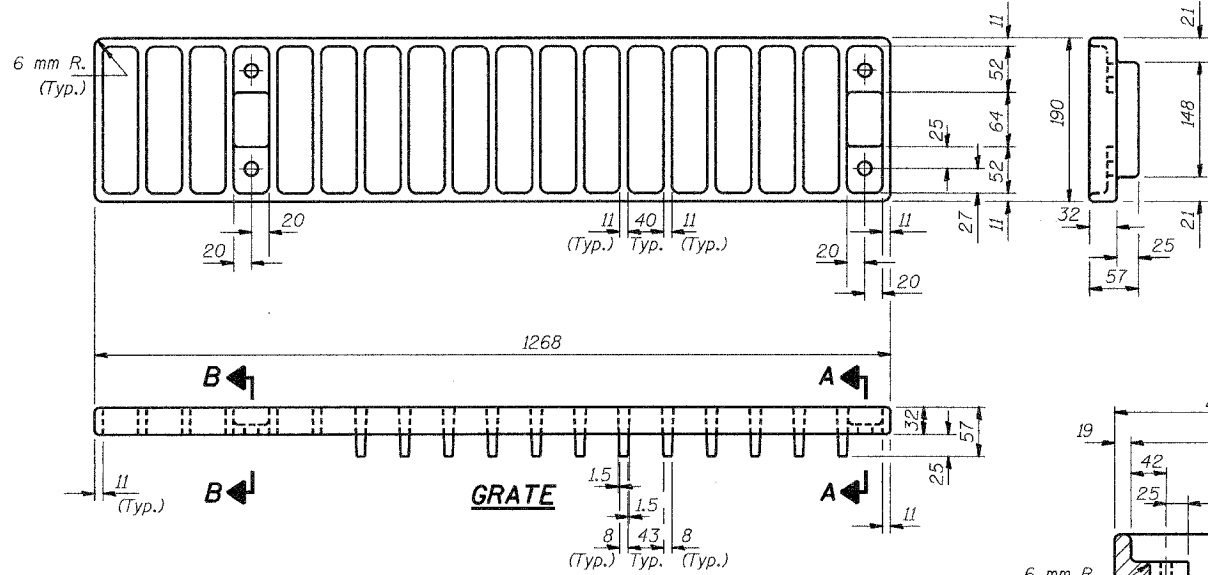

GRATE

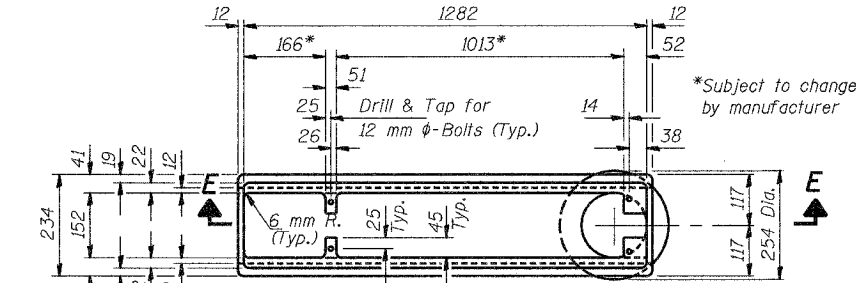

FRAME

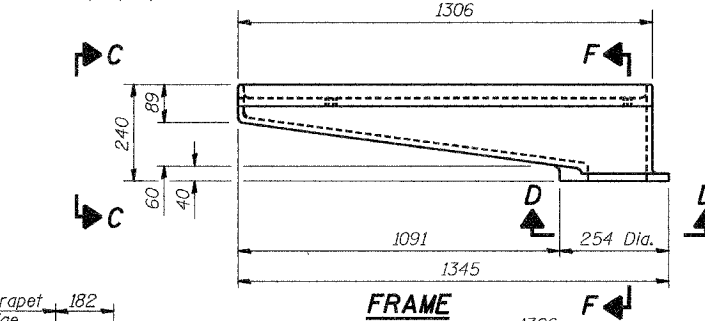

FRAME

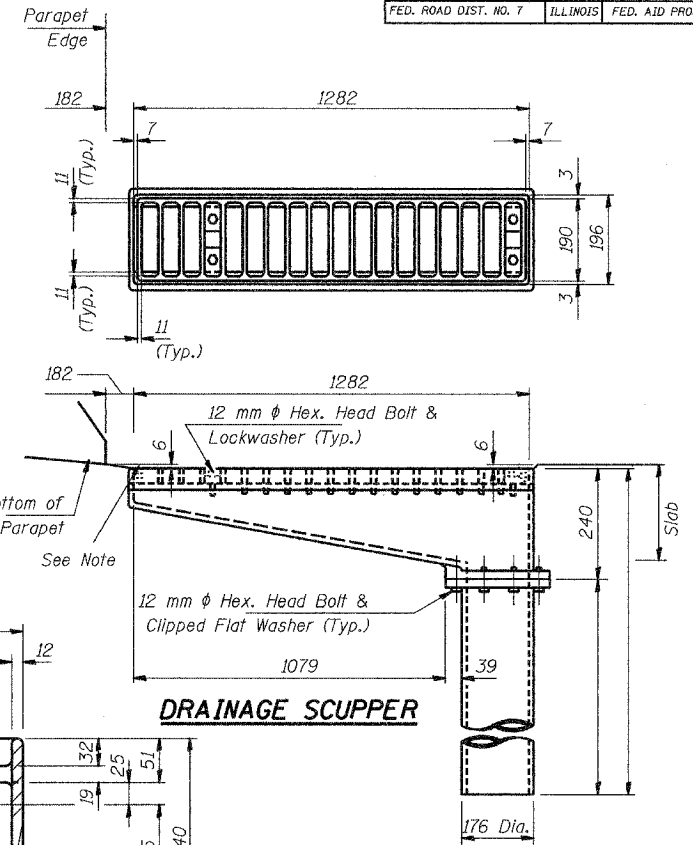

DRAINAGE SCUPPER

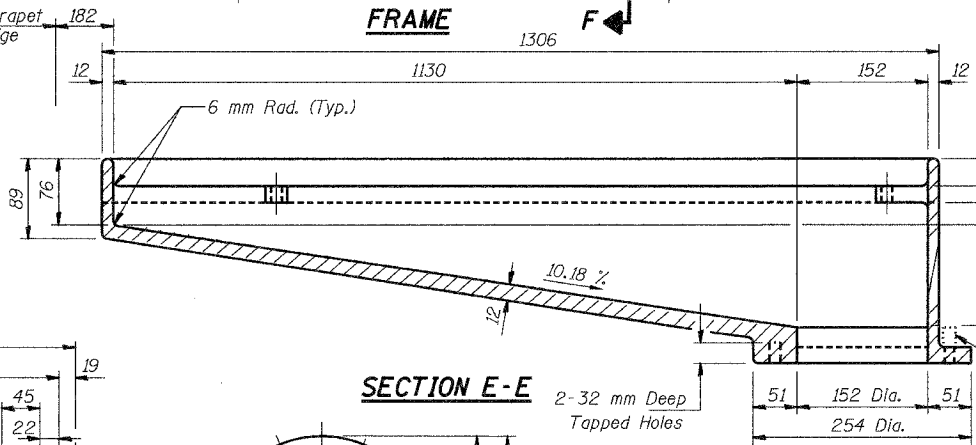

SECTION E-E

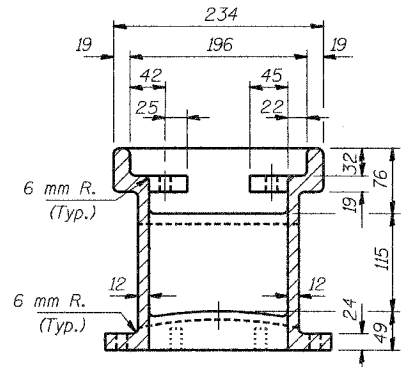

SECTION F-F

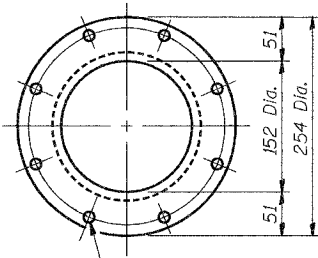

VIEW D-D

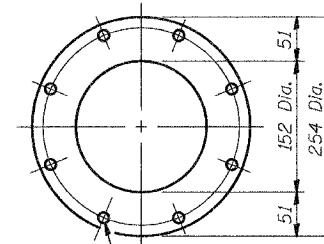

VIEW D-D

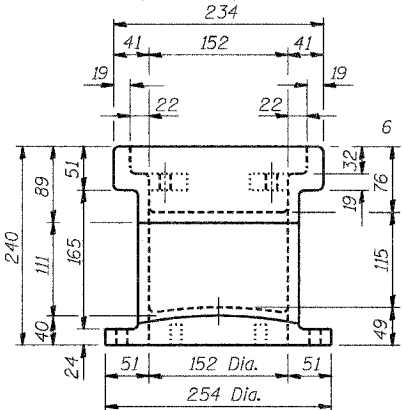

VIEW C-C

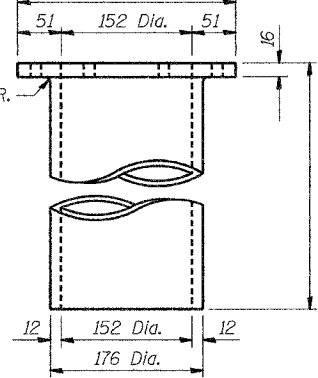

DOWNSPOUT

Notes: All cast iron parts shall be gray iron conforming to the requirements of AASHTO M 105, Class 30.
Bolts and washers shall conform to the requirements of ASTM A 307.
All bolts and washers shall be galvanized according to AASHTO M 232.
As an alternate bolts and washers may be stainless steel.
Cost of the Grate, Frame, Downspout, bolts and washers including complete installation of Scupper will be paid for at the unit bid price each for DRAINAGE SCUPPERS, TYPE 2.
The Contractor may use at his option steel drainage scuppers or cast iron drainage scuppers.
All dimensions are in millimeters (mm) except as noted.

DESIGNED	
CHECKED	
DRAWN	VH
CHECKED	

BILL OF MATERIAL

ITEM	UNIT	QUANTITY
Drainage Scuppers, Type 2	Each	2

DRAINAGE SCUPPER, TYPE 2 DETAILS

Date	Designed	INTERSTATE 74 AND RAMPS L-1 AND L-4 OVER E. WASHINGTON STREET F.A.I. RTE. 74 SECTION (90-14HB)BR TAZEWELL COUNTY STATION 153+868.540 STRUCTURE NO. 090-0163 (WB)	Sheet No.
Revisions	Drawn BKN		13
	Checked		
	Approved KWB		
Prepared By:	URS	3040 North University Avenue Decatur, IL 62526	of 28 URS Job No. 2100001243.01