

F.A.P. RTE.	SECTION	COUNTY	TOTAL SHEETS	SHEET NO.
709	105BR	CHAMPAIGN	36	14

CONTRACT: 70391

DETAIL OF RURAL FIELD ENTRANCES

ADJACENT TO PROPOSED RESURFACING, 2 1/2" (AGGREGATE)

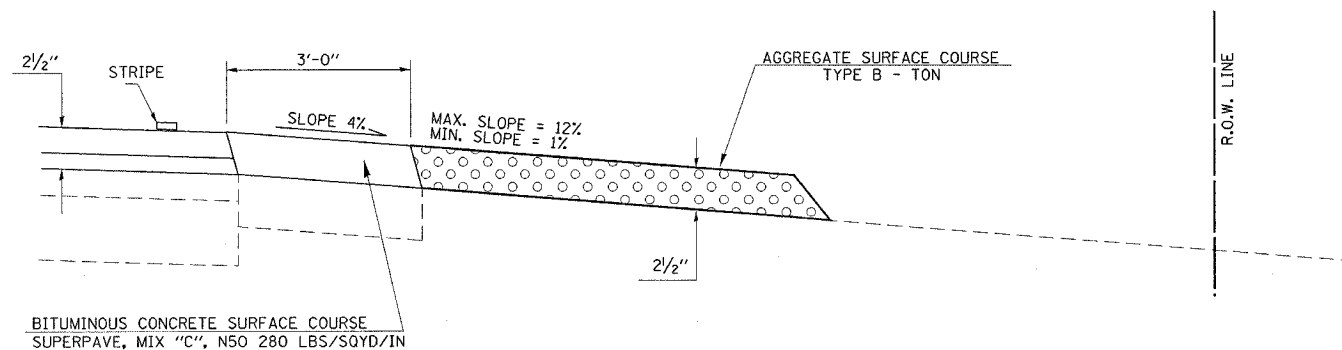

NOTE: THE INCIDENTAL BITUMINOUS SURFACING IS INTENDED TO RESURFACE THE EXISTING ENTRANCES IN THEIR ENTIRETY. THE EXISTING ENTRANCES SHOULD BE RESURFACED TO MAINTAIN THEIR CURRENT RADII.

PROFILE

DETAIL OF POROUS GRANULAR BACKFILL PAY LIMITS

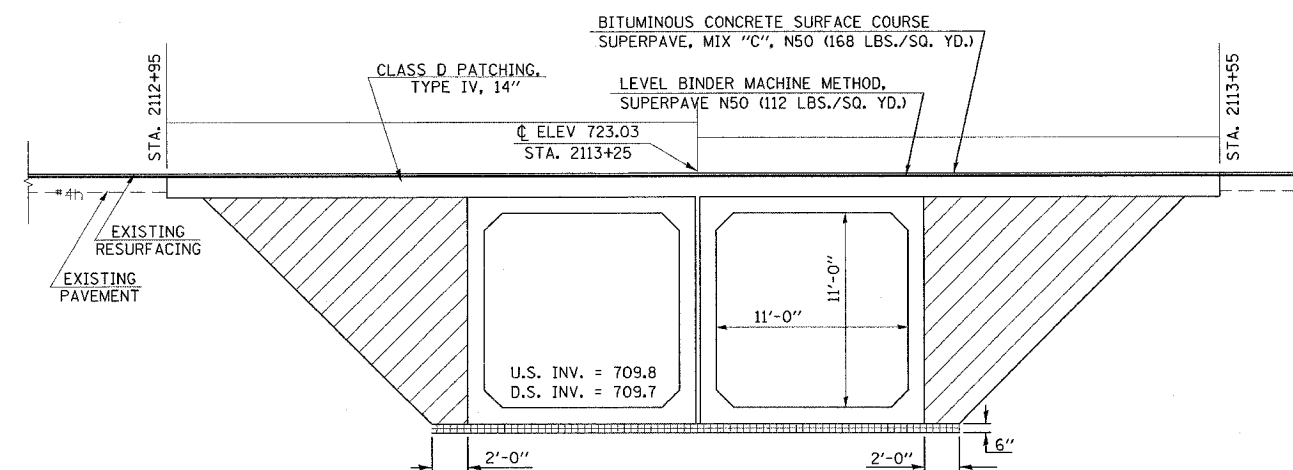

/// PAY LIMITS OF POROUS GRANULAR BACKFILL - CA 6
 NOTE: POROUS GRANULAR BACKFILL SHALL EXTEND 18'-0" EACH SIDE OF F.A.P. 709 CENTERLINE
 PLAN TOTAL = 288.0 CUYDS

□ PROPOSED DOUBLE 11'-0" x 11'-0" x 43'-6" PRECAST CONCRETE BOX CULVERT
 A.R. STATION 2113+25

□ POROUS GRANULAR MATERIAL - CA 7 (6")
 (INCLUDED IN PAY ITEM FOR PRECAST BOX CULVERT)

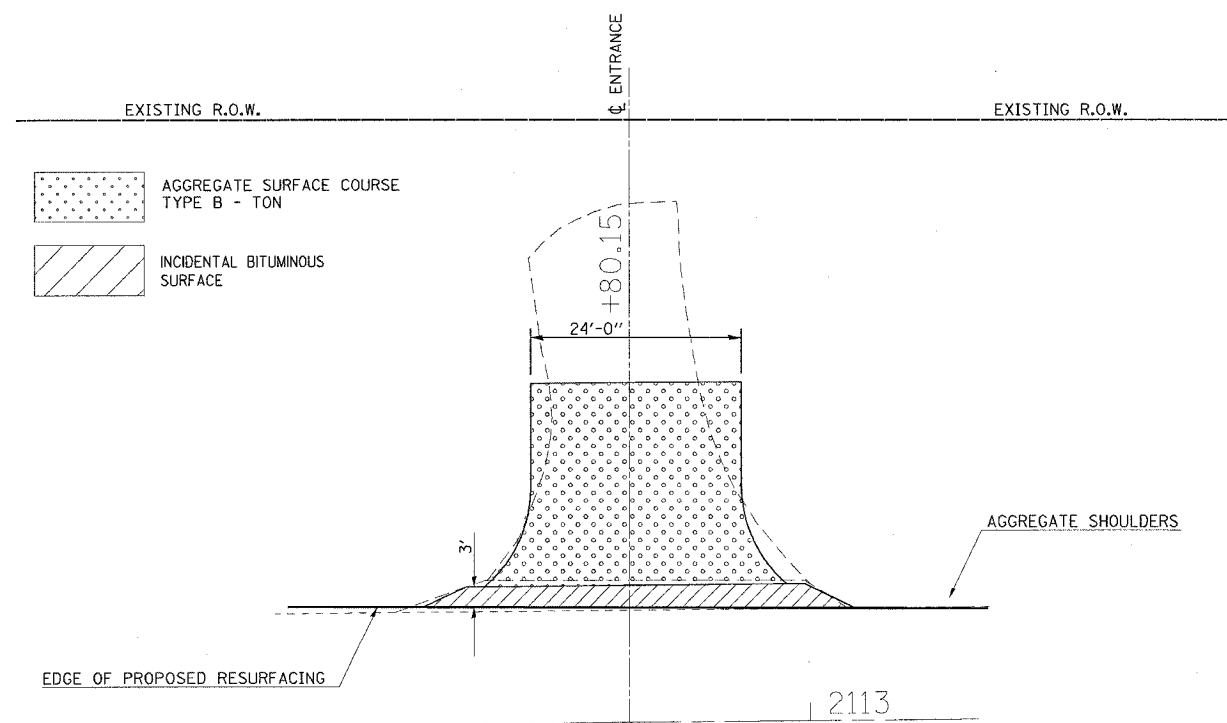

PLAN

DETAIL OF EXPANSION BOLT, 3/4" LAYOUT

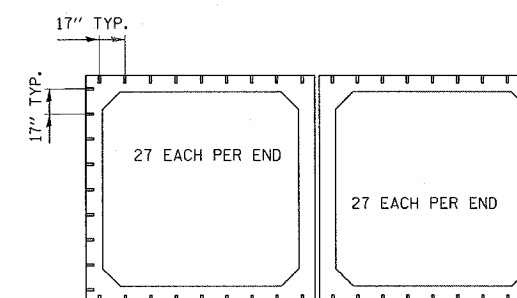

27 EACH PER END X 4 ENDS = 108 EACH

ATTACHING TO EXISTING WEIRS
 USE 4 EACH X 3 WEIRS = 12 EACH

TOTAL QUANTITY
 EXPANSION BOLTS, 3/4" = 120 EACH