

F.A.P. RTE.	SECTION	COUNTY	TOTAL SHEETS	SHEET NO.
662		MACOUPIN	74	25
STA.	TO STA.			
FED. ROAD DIST. NO.	ILLINOIS	FED. AID PROJECT		

• 10Z (RS-1); (V,T) R-2; SIRS-4)

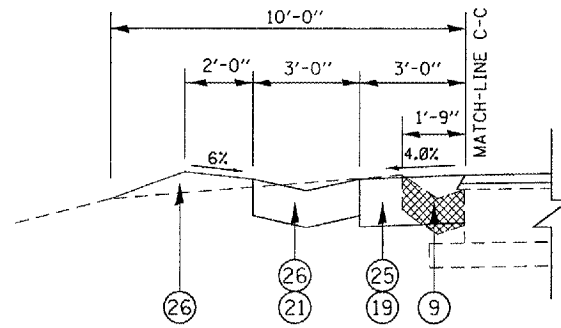

PART A

- LT STA 146+99.95 TO LT STA 148+50.00
- LT STA 148+50.00 TO LT STA 148+62.00 - PR TY-A GUTTER INLET
- LT STA 148+62.00 TO LT STA 149+12.00 - TRANS. 3' BIT. SHLD. TO 1' BIT. SHLD. - NO PR GUTTER
- LT STA 208+00.00 TO LT STA 208+50.00 - TRANS. 3' BIT. SHLD. TO 1' BIT. SHLD. - NO PR GUTTER
- LT STA 233+14.00 TO LT STA 233+50.00 - PR TY-A GUTTER OUTLET
- LT STA 233+50.00 TO LT STA 238+96.00 - PR TY-A GUTTER OUTLET
- LT STA 238+96.00 TO LT STA 239+50.00 - PR TY-A GUTTER OUTLET
- LT STA 239+50.00 TO LT STA 245+06.39
- RT STA 233+14.00 TO RT STA 233+50.00 - PR TY-A GUTTER OUTLET
- RT STA 233+50.00 TO RT STA 238+96.00 - PR TY-A GUTTER OUTLET; EX CONC. GUTTER OUTLET, INLET BOX, GRATES, AND CMP DRAIN PIPE TBR
- RT STA 239+50.00 TO RT STA 244+73.00
- RT STA 244+73.00 TO RT STA 244+85.00 - PR GUTTER INLET.

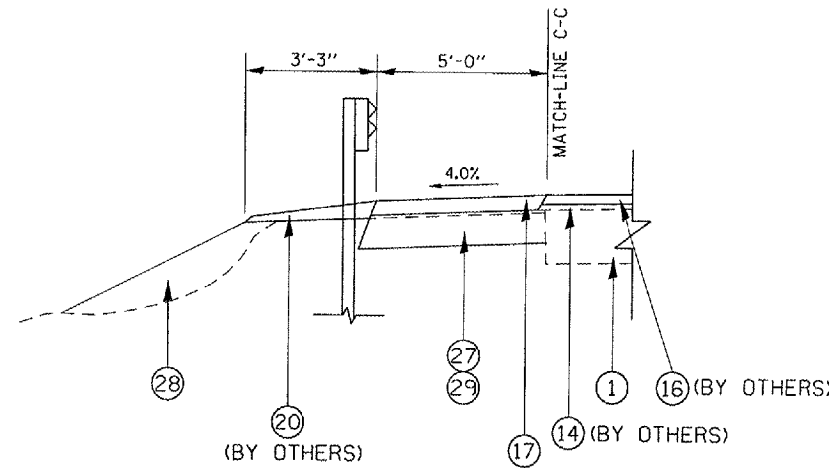

PART A

- LT STA 442+85.00 TO LT STA 444+62.81 - NO PR GUARDRAIL
- LT STA 444+62.81 TO LT STA 446+25.50 - PR GUARDRAIL (BY OTHERS)
- LT STA 446+25.50 TO LT STA 447+91.50 - PR BRIDGE & BRIDGE APPR. PAVEMENT (BY OTHERS)
- LT STA 447+91.50 TO LT STA 450+70.81 - PR GUARDRAIL (BY OTHERS)
- LT STA 450+70.81 TO LT STA 450+94.81 - TRANS. 5' BIT. SHLD. TO 1' BIT. SHLD. - NO PR GUARDRAIL
- RT STA 442+67.00 TO RT STA 443+36.79 - NO PR GUARDRAIL
- RT STA 443+36.79 TO RT STA 446+16.20 - PR GUARDRAIL (BY OTHERS)
- RT STA 446+16.20 TO RT STA 447+91.40 - PR BRIDGE & BRIDGE APPR. PAVEMENT (BY OTHERS)
- RT STA 447+91.40 TO RT STA 449+63.54 - PR GUARDRAIL (BY OTHERS)
- RT STA 449+63.54 TO RT STA 450+65.00 - NO PR GUARDRAIL
- RT STA 450+65.00 TO RT STA 450+74.00 - TRANS. 5' BIT. SHLD. TO 1' BIT. SHLD.

LEGEND

- ① EX PCC PAVEMENT, 9"
- ② EX PCC PAVEMENT, 7"-8"-7"
- ③ EX PCC BASE COURSE WIDENING, 8"
- ④ EX PCC BASE COURSE WIDENING, 9"
- ⑤ EX BITUMINOUS BASE COURSE WIDENING, 8"
- ⑥ EX PCC BASE COURSE, 8"
- ⑦ EX BITUMINOUS CONC. SURFACE
- STA 129+96.00 TO STA 131+20.00 - 2 1/2"
- STA 131+20.00 TO STA 265+80.00 - 0"
- STA 265+80.00 TO STA 321+81.00 - 7" ± 1"
- STA 321+81.00 TO STA 349+61.00 - 0"
- STA 349+61.00 TO STA 399+40.00 - 7" ± 2"
- STA 399+40.00 TO STA 478+00.00 - 0"
- ⑧ EX SUB-BASE GRANULAR MATERIAL
- ⑨ EX CONCRETE GUTTER, TYPE B (TO BE REMOVED)
- ⑩ EX STEEL PLATE BEAM GUARDRAIL
- ⑪ EX COMBINATION CONC. CURB & GUTTER
- ⑫ PR BIT. SURFACE REMOVAL, VAR. DEPTH
- ⑬ PR LEVELING BINDER (MACHINE METHOD), SUPERPAVE, 3/4" AVG. (SEE BIT. MIXTURE TABLE)
- ⑭ PR LEVELING BINDER (MACHINE METHOD), SUPERPAVE, 1" AVG. (SEE BIT. MIXTURE TABLE)
- ⑮ PR LEVELING BINDER (MACHINE METHOD) SUPERPAVE, VAR. DEPTH (1/2" MIN) (SEE BIT. MIXTURE TABLE)
- ⑯ PR BIT. CONCRETE SURFACE COURSE, SUPERPAVE 1 1/2" (SEE BIT. MIXTURE TABLE)
- ⑰ PR BIT. SHLDS, SUPERPAVE, 2-1/2" (SEE BIT. MIXTURE TABLE)
- ⑱ PR BIT. SHLDS, SUPERPAVE, 8" (SEE BIT. MIXTURE TABLE)
- ⑲ PR BIT. SHLDS, SUPERPAVE, 8" (SEE BIT. MIXTURE TABLE)
- ⑳ PR AGG. SHLDS., TYPE B
- ㉑ PR CONC. GUTTER, TY-A (STD 606101)
- ㉒ PR PREFORMED PLASTIC PAVMENT MARKING, TY-B, LINE - 5"
- ㉓ PR PAINT PAVMENT MARKING, LINE - 5"
- ㉔ PR GRADING AND SHAPING SHOULDERS
- ㉕ PR EXCAVATING AND GRADING EX SHLD.
- ㉖ PR EXCAVATING AND GRADING EX SHLD., SPECIAL
- ㉗ PR EARTH EXCAVATION WIDENING
- ㉘ PR EARTH EMBANKMENT
- ㉙ PR BIT. BASE COURSE WIDENING, SUPERPAVE, 10" (SEE BIT. MIXTURE TABLE)

REVISIONS	
NAME	DATE

ILLINOIS DEPARTMENT OF TRANSPORTATION

PART A
TYPICAL SECTIONS

SCALE: VERT.
HORIZ.
DATE 04-07-03

DRAWN BY MAW
CHECKED BY