

BATTERY BACKUP SYSTEM (BBS) BLOCK DIAGRAM

- NOTES
1. TRANSFER RELAY MAY BE INTERNAL TO THE INVERTER
 2. MANUAL BYPASS SWITCH SHALL BE EXTERNAL TO INVERTER/CHARGER AND TRANSFER RELAY

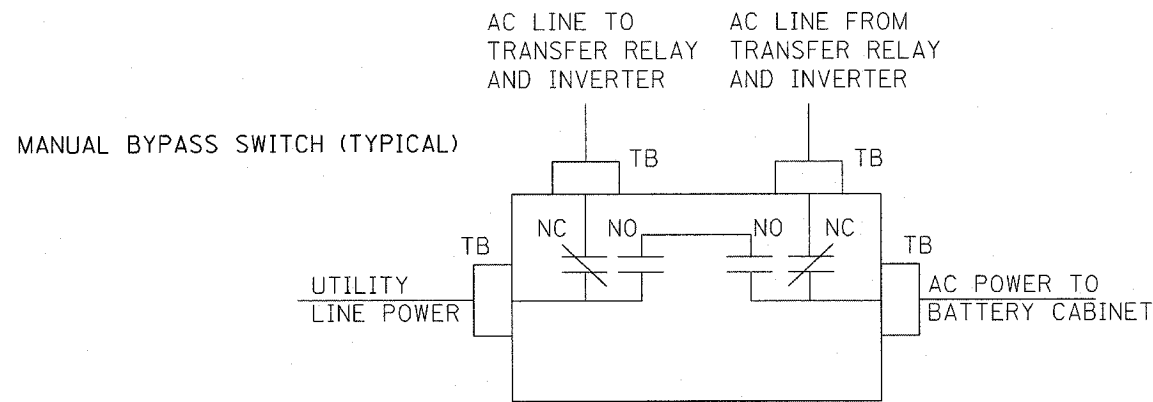

MANUAL BYPASS SWITCH (TYPICAL)

- NOTES
1. TB - #8 TERMINAL BLOCKS
 2. NO - NORMALLY OPEN
 3. NC - NORMALLY CLOSED
 4. NO/NC CONTACTS SHALL ALL TOGGLE SIMULTANEOUSLY WITH ONE SINGLE MANUALLY OPERATED SWITCH
 5. MANUAL BYPASS SWITCH SHALL ONLY SWITCH LINE. NEUTRAL AND EQUIPMENT GROUND ARE NOT SWITCHED AND SHALL BE CONNECTED TO BATTERY CABINET BUSES

RELAY CONTACTS (NO/NC) AVAILABLE ON PANEL-MOUNTED TERMINAL BLOCK (TYPICAL)

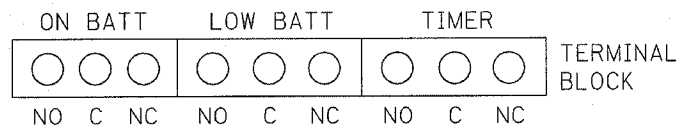

NOTES

1. NO/NC CONTACTS MAY EITHER SHARE OR USE SEPARATE COMMONS

BATTERY BACKUP SYSTEM (BBS) BLOCK DIAGRAM

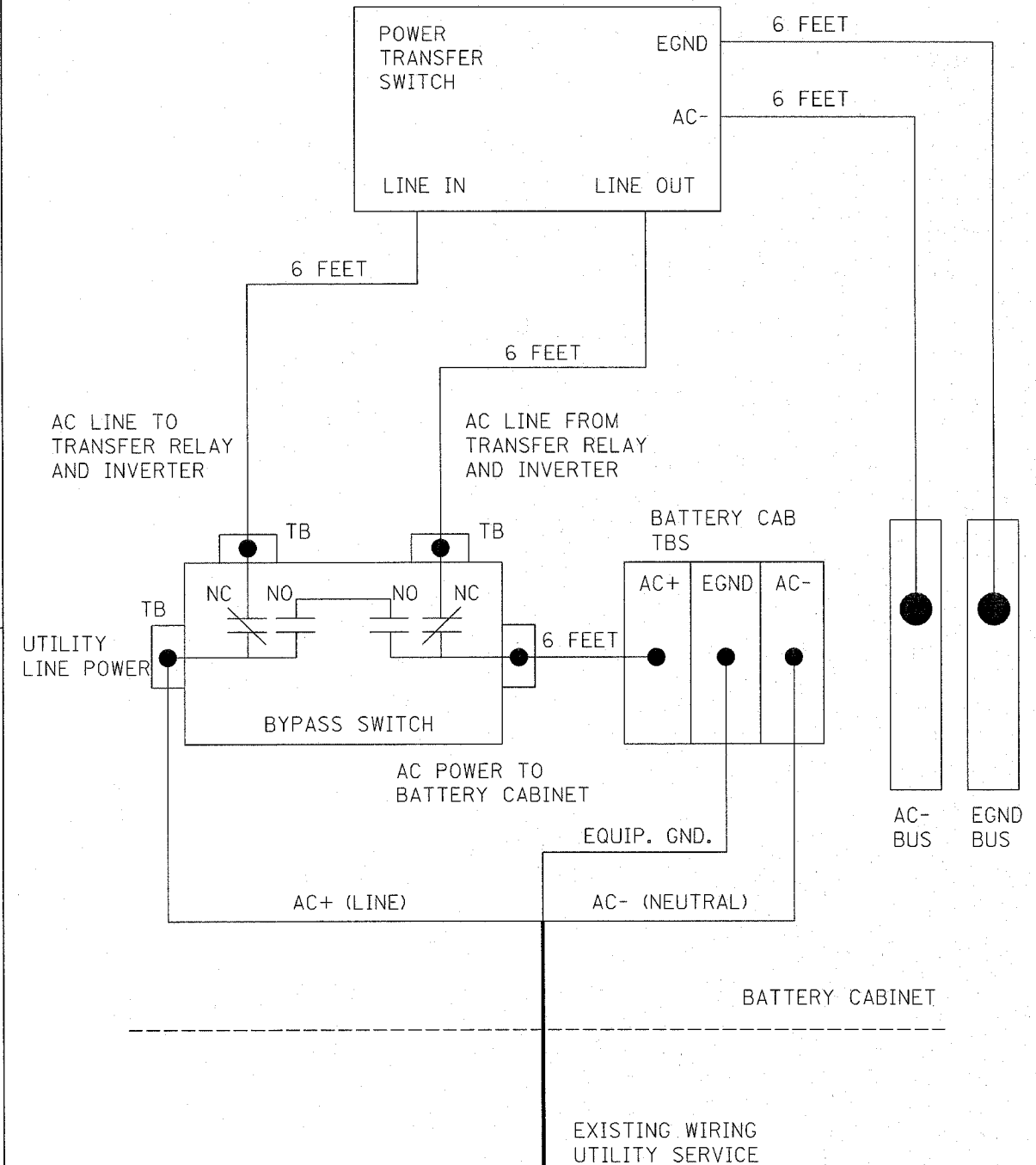

BBS UTILITY POWER CONNECTION DIAGRAM

REVISIONS	
NAME	DATE

ILLINOIS DEPARTMENT OF TRANSPORTATION
BATTERY BACKUP SYSTEM DETAILS

SCALE: VERT.
HORIZ.
DATE

DRAWN BY
CHECKED BY