

STATE OF ILLINOIS
DEPARTMENT OF TRANSPORTATION

ROUTE NO.	SECTION	COUNTY	TOTAL SHEETS	SHEET NO.	SHEET NO.
F.A.I. 55	D-6 ITS #1	SANGAMON		42	42
FED. ROAD DIST. NO. 7	ILLINOIS	FED. AID PROJECT-			

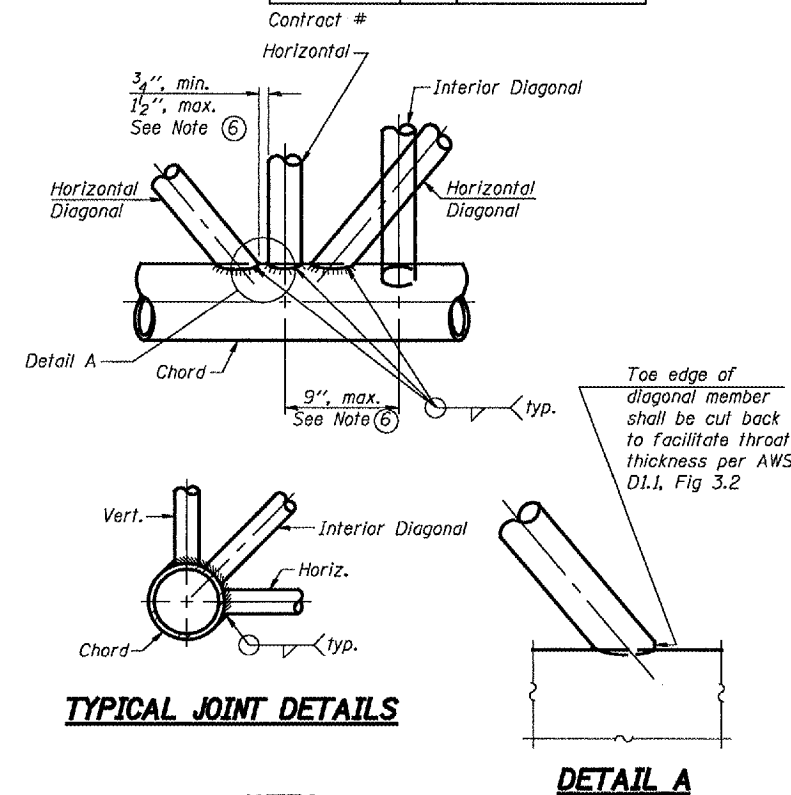

- NOTES**
- Contractor may alternatively use standard aluminum drive-fit cap to close end. 1/2" φ drain hole in end plate/drive-fit cap. (Typ. at ends of all chords)
 - 5 1/2" end dimension may vary by ±1" to provide uniform panel spacing (P).
 - Panel spacing (P) shall be uniform for entire truss and between 4'-0" and 5'-0" for Type I-A or 4'-0" and 5'-6" for Types II-A and III-A.
 - Vertical Diagonals in front and back face shall alternate.
 - Hidden lines show wind bracing alternates direction between planes of top and bottom chords.
 - All diagonals shall be detailed for minimum offset from the panel point based on the following: Offset shall be such as to provide a 3/4" minimum to 1 1/2" maximum clearance between any diagonal and any horizontal or vertical member, and to provide clearance for U-bolt connections of signs or walkway brackets.

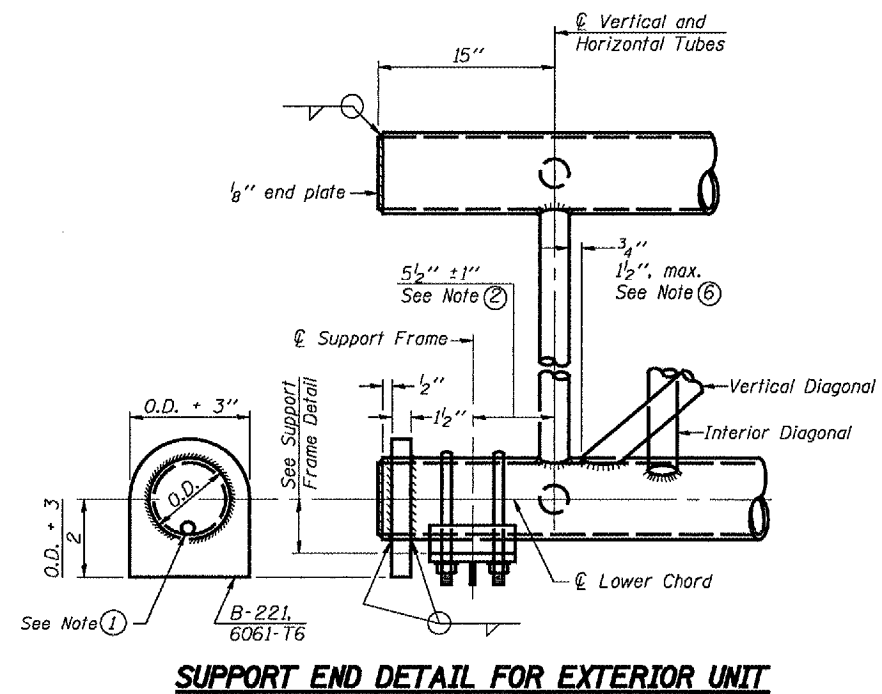
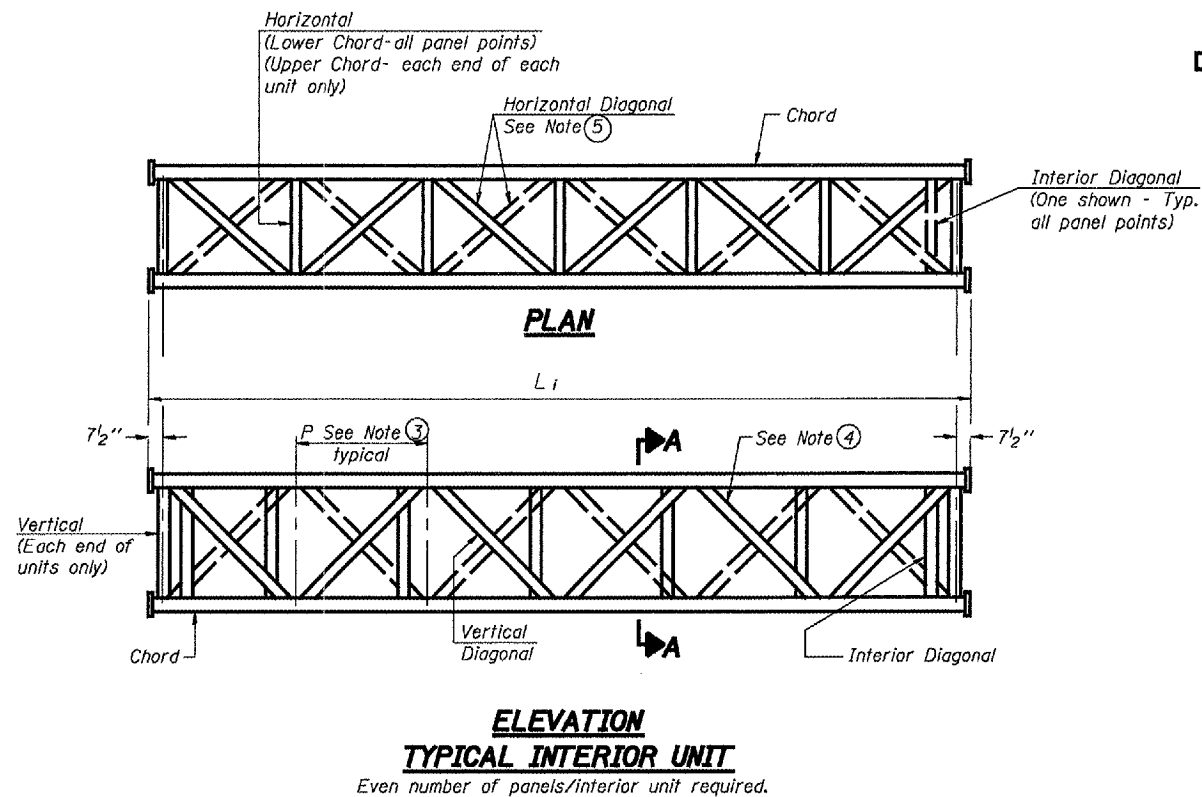
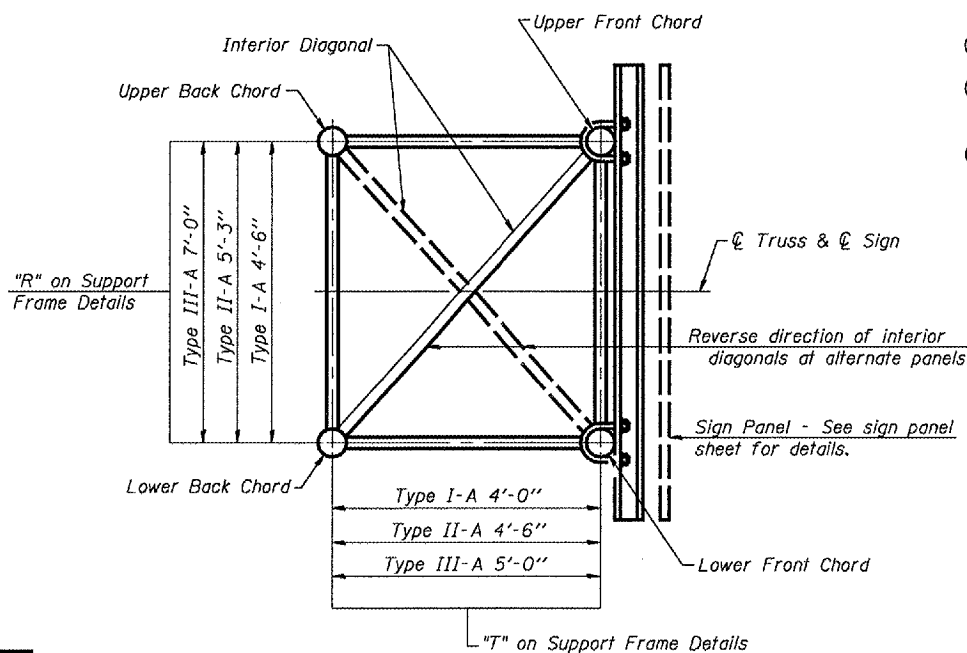
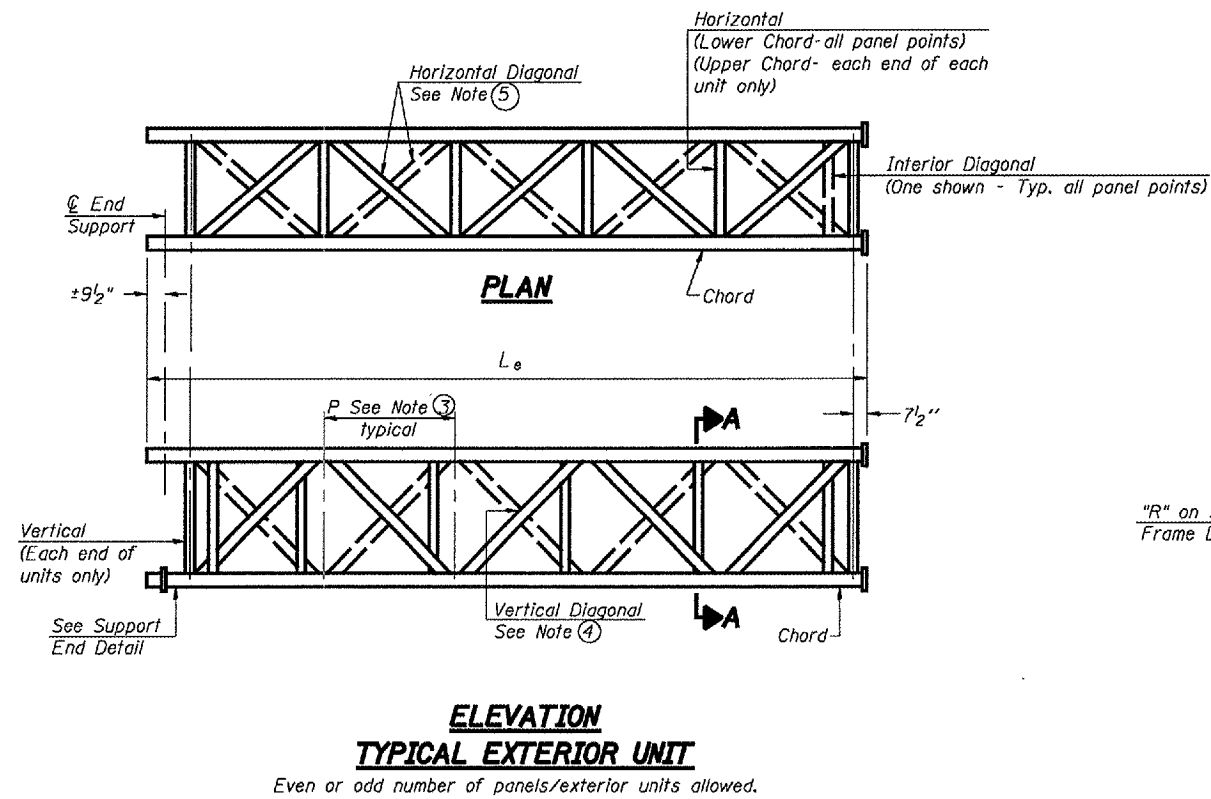

**OVERHEAD SIGN STRUCTURES
ALUMINUM TRUSS DETAILS
FOR TRUSS TYPES I-A, II-A and III-A**

F.A.I. 55 (I-55)
SECTION D-6 ITS #1
SANGAMON COUNTY

DESIGNED -	200
CHECKED -	EXAMINED
DRAWN -	PASSED
CHECKED -	ENGINEER OF BRIDGES AND STRUCTURES

NUMBER	REVISION	DATE