

STATE OF ILLINOIS
DEPARTMENT OF TRANSPORTATION

ROUTE NO.	SECTION	COUNTY	TOTAL SHEETS	SHEET NO.	SHEET NO.
F.A.I. 55	D-6 ITS #1	SANGAMON		46	SHEETS
FED. ROAD DIST. NO. 7	ILLINOIS	FED. AID PROJECT			

Contract #

Hexagon locknut and washer (top), leveling nut and washer (bottom). Galvanize per AASHTO M232. Nuts shall each be tightened against base plate with 200 lb.-ft. minimum torque.

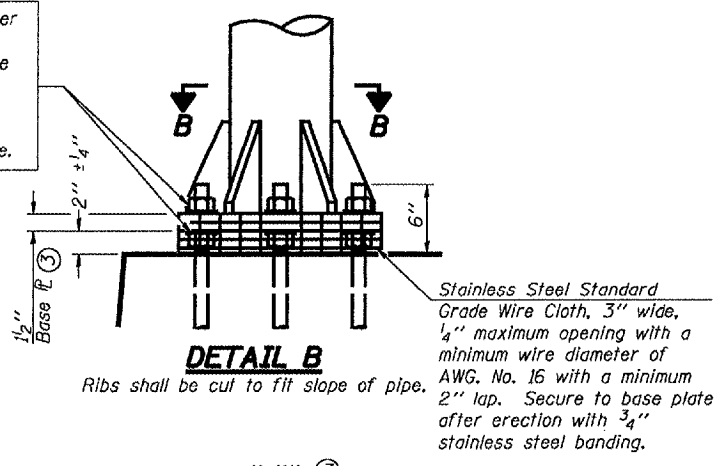

DETAIL B

Ribs shall be cut to fit slope of pipe.

Stainless Steel Standard Grade Wire Cloth, 3" wide, 1/4" maximum opening with a minimum wire diameter of AWG. No. 16 with a minimum 2" lap. Secure to base plate after erection with 3/4" stainless steel banding.

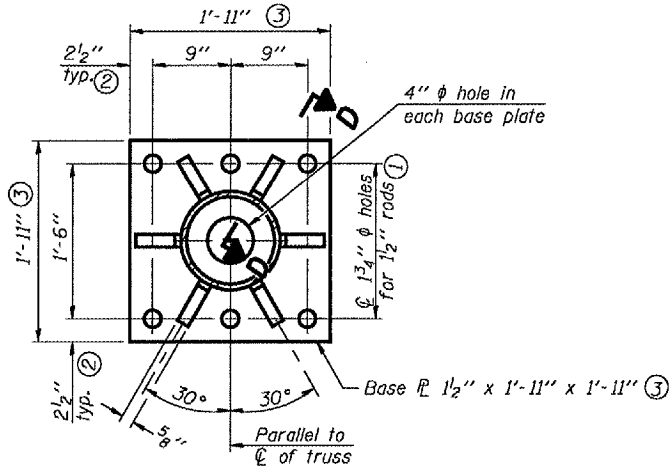

SECTION B-B

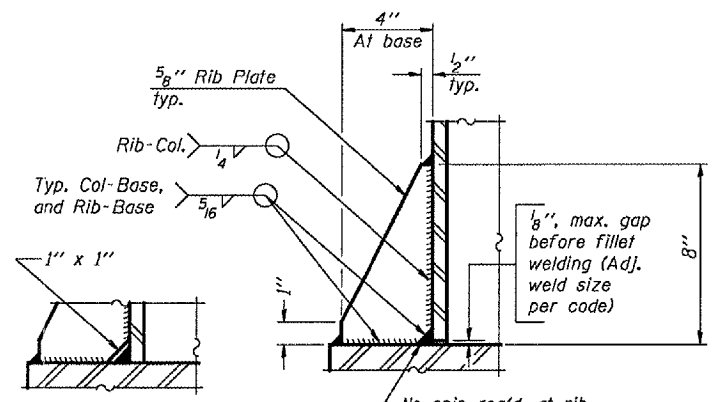

SECTION D-D

** Alternate detail if welding col. to base plate first, then snip inside corner of ribs. Terminate weld on rib 1/4" from snip.

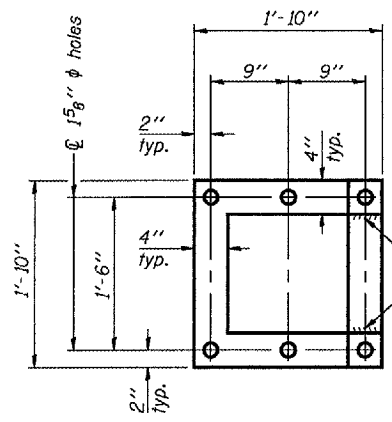

POSITIONING PLATE(S)

Optionally may use four (4) separate bars. Weld to maintain perpendicularity.

At each location, provide 1/4" thick positioning plate(s) and six (6) additional nuts to be used with leveling nuts to maintain anchor bolts position during concrete placement.

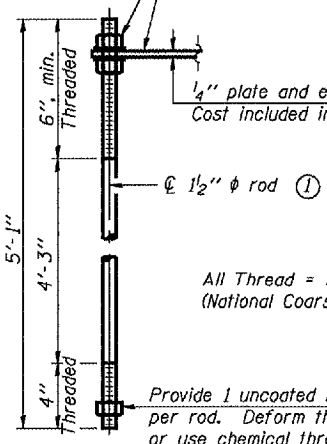

ANCHOR ROD DETAIL

Anchor rods shall conform to AASHTO M314 Grade 36 or 55 and meet Charpy V-Notch (CVN) energy of 15 lb.-ft. at 40° F. Galvanize upper 12" per AASHTO M232. No welding shall be permitted on rods.

**TYPE III-A TRUSS
12" φ PIPE SUPPORT FRAME DETAILS**

Notes:
For Type III-A Truss spans greater than 150 ft. and up to 160 ft.:

- ① 1 3/4" φ rod, 2" φ holes
- ② 2 3/4" edge distance
- ③ Base plate 1 5/8" x 1'-11 1/2" x 1'-11 1/2"

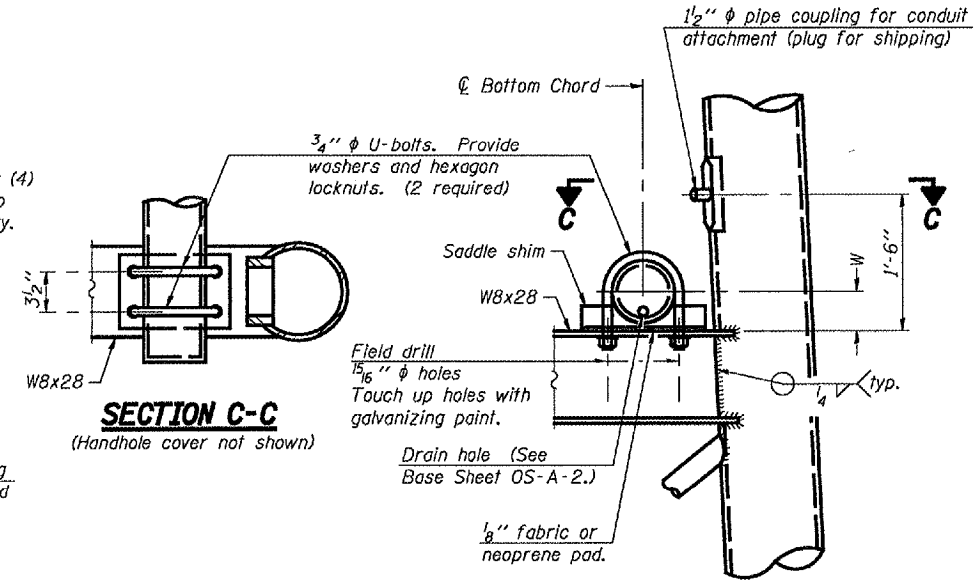

DETAIL C

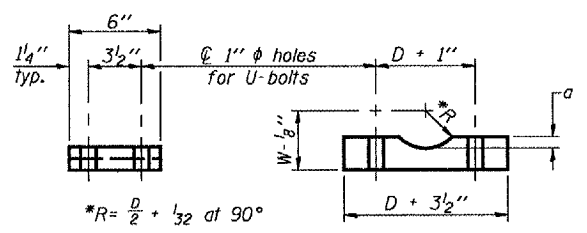

SADDLE SHIM DETAIL

ASTM B26 Alloy 356-F
or
ASTM B209 Alloy 6061-T651
(4 required per sign truss)

Truss Chord Nominal Dia.	a
7"	1"
8 1/2"	1 1/4"
9"	1 3/8"

DESIGNED -	200
CHECKED -	ENGINEER OF BRIDGE DESIGN
DRAWN -	ENGINEER OF BRIDGES AND STRUCTURES
CHECKED -	

NUMBER	REVISION	DATE

**OVERHEAD SIGN STRUCTURES
SUPPORT FRAME for TYPE III-A ALUMINUM TRUSS**

F.A.I. 55 (I-55)
SECTION D-6 ITS #1
SANGAMON COUNTY