

F.A.U. R.T.E.	SECTION	COUNTY	TOTAL SHEETS	SHEET NO.
5012	02-00098-00-FP	BOONE	30	30

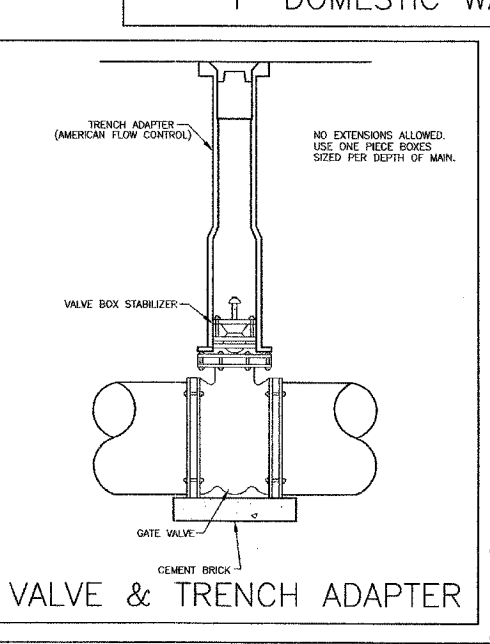
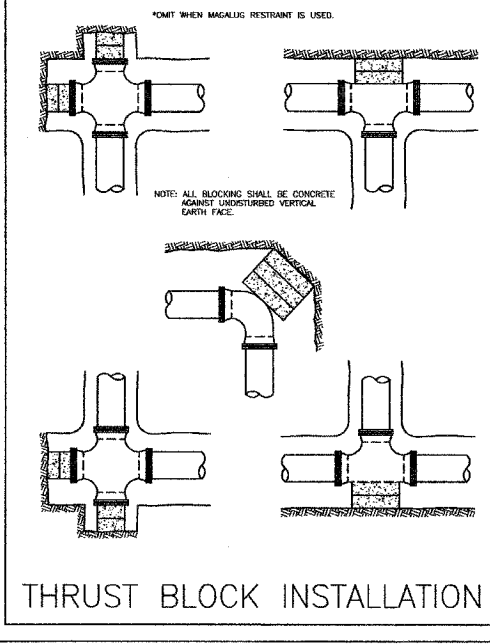
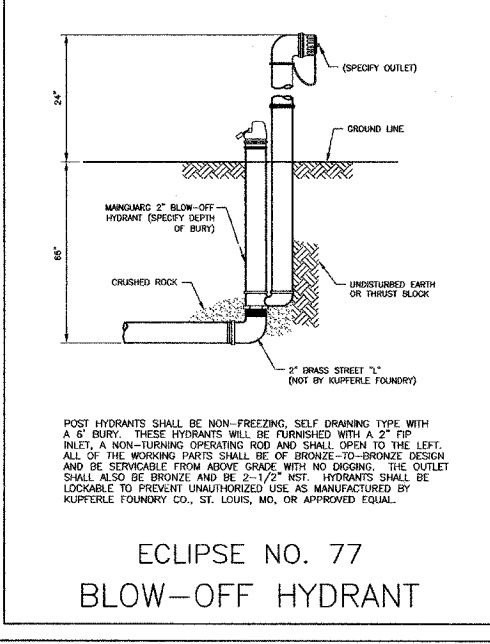
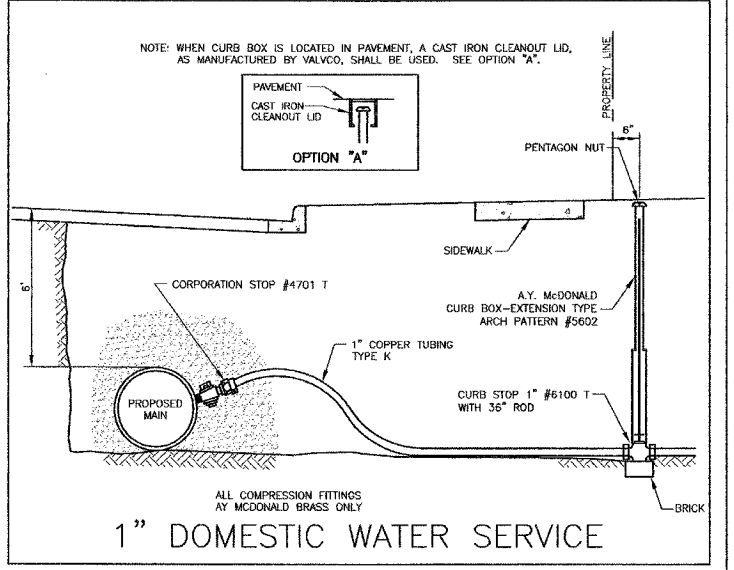
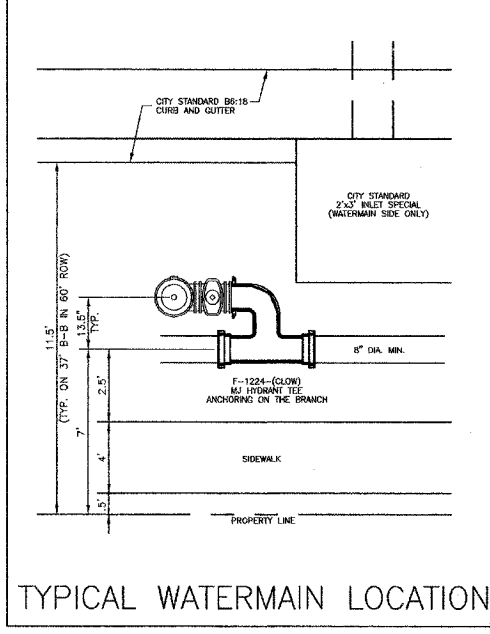
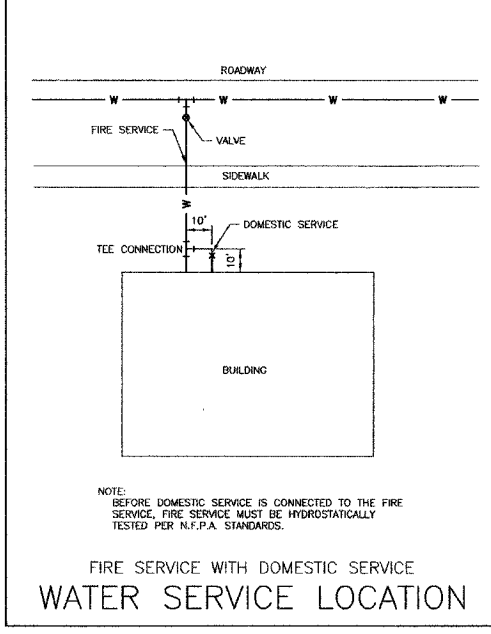
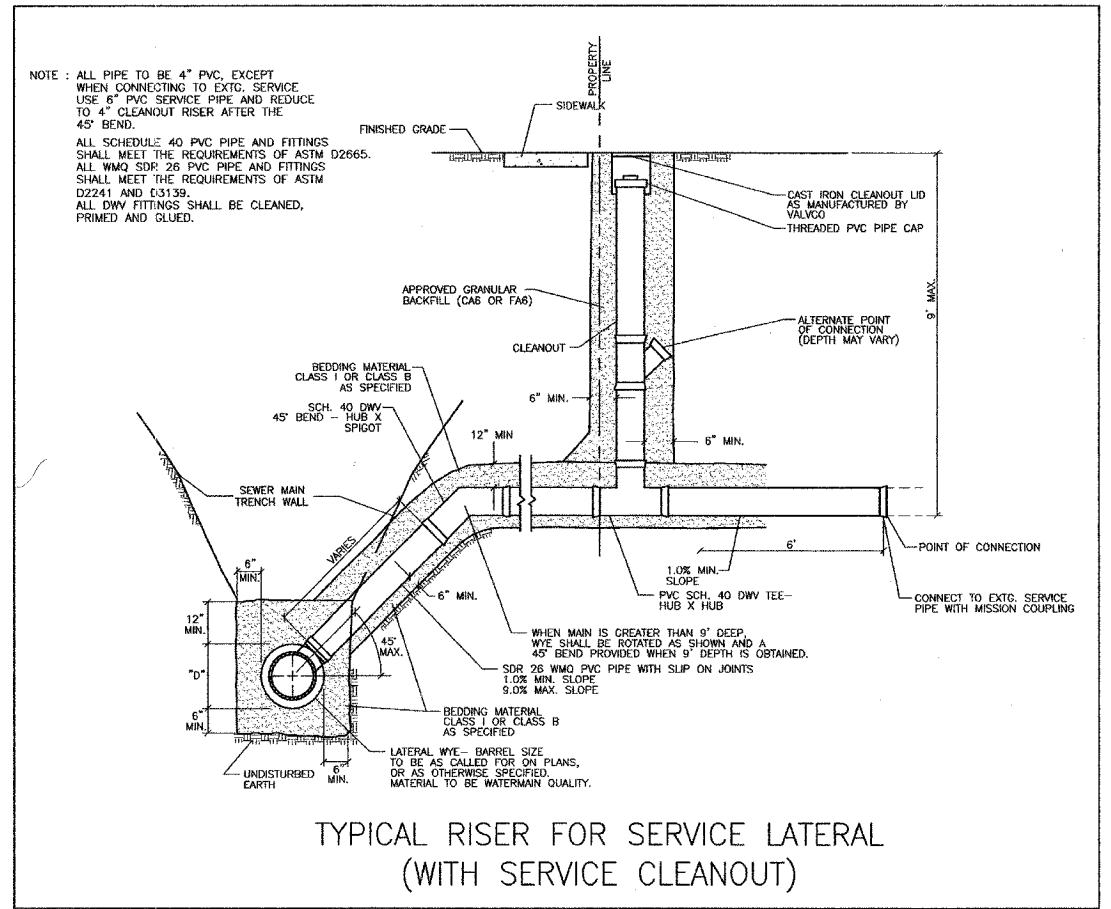
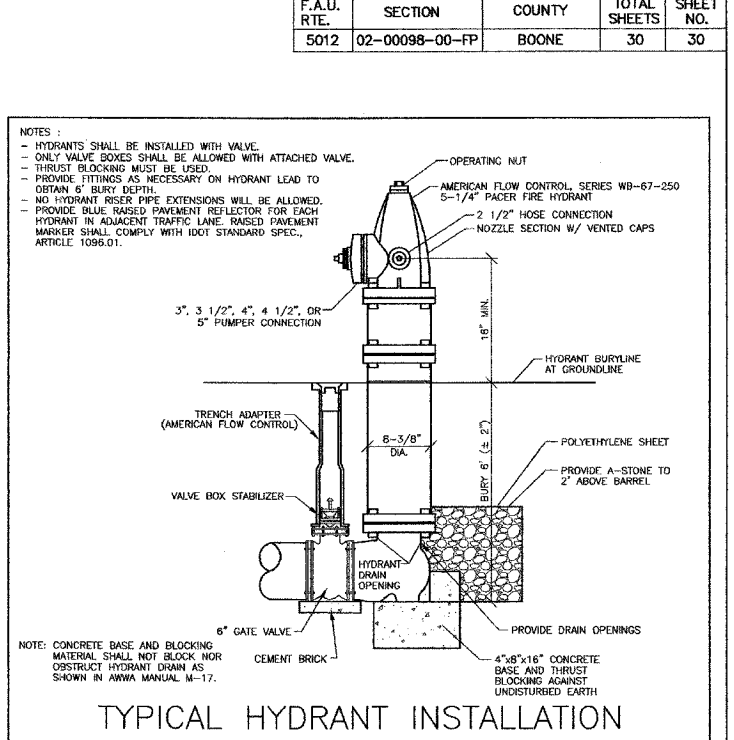
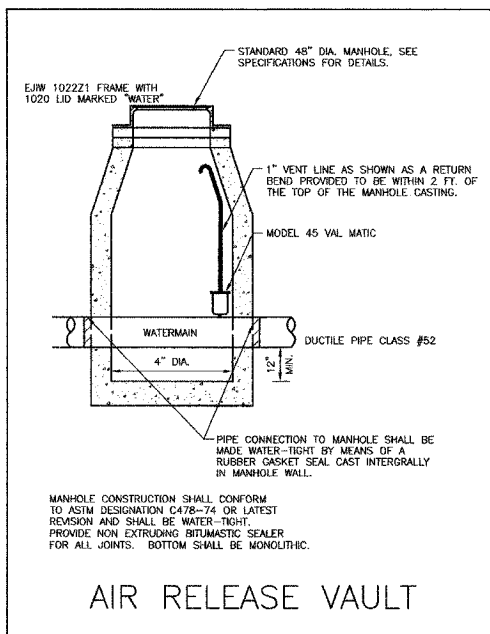
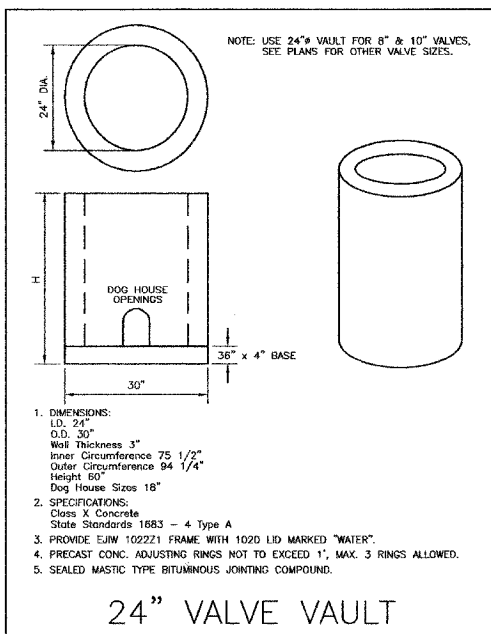
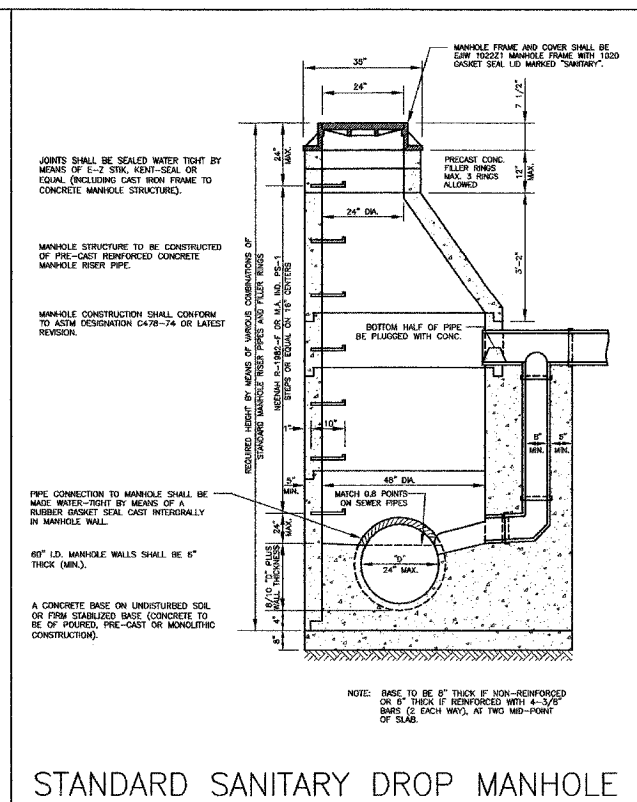
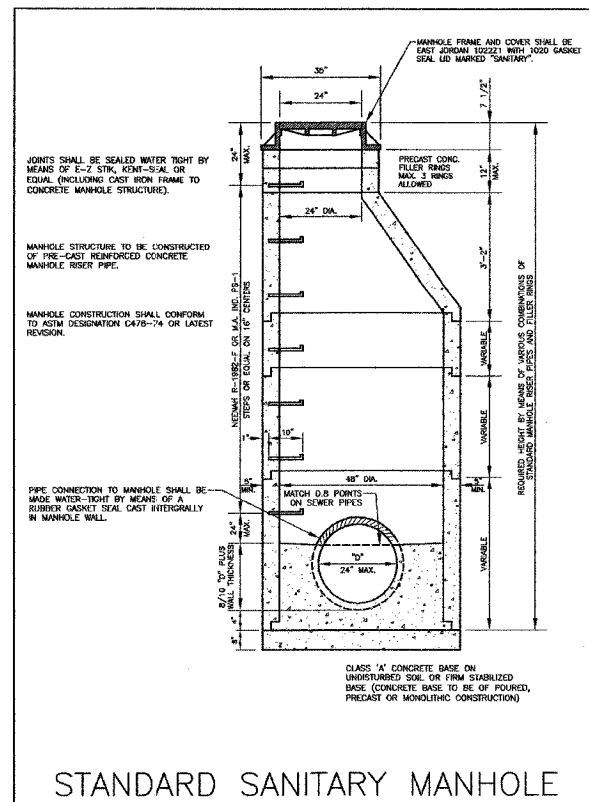

SANITARY SEWER AND WATER DETAILS

CITY OF BELVIDERE

BY: J. GRIMES DATE: 09/20/2002 SHT. NO. 2 OF 2

REV: 03/23/2005