

COUNTY DISTRICT NO.	SECTION	COUNTY	TOTAL SHEETS	SHEET NUMBER
21	*	MCLEAN	3	3
FED. RD. DIST. #7 ILLINOIS PROJECT #				

* 02-00044-07-WR
CONTRACT NO. 87301

MAILBOX TURNOUT
3 @ 42 SQ YDS EACH

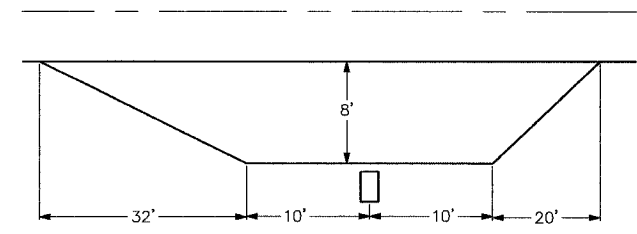

NOTE: MULTIPLE MAILBOX CLUSTERS TO BE EXTENDED 2' FOR EACH ADDITIONAL MAILBOX.

FIELD ENTRANCE
35 @ 42 SQ YDS EACH

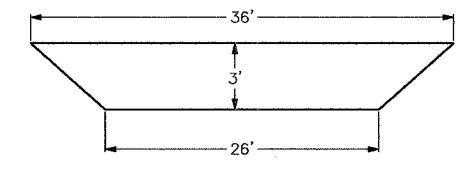

TYPICAL SIDE ROAD RETURN
8 @ 129 SQ YDS EACH

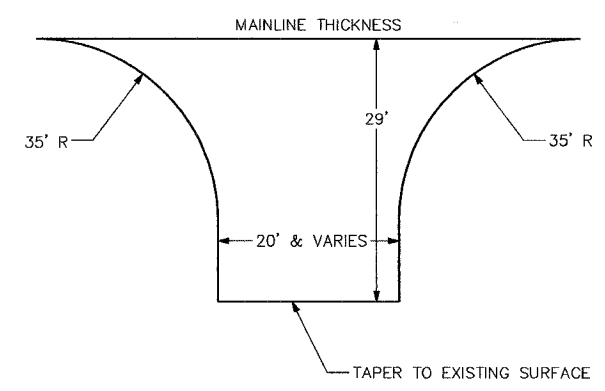

SPECIAL INTERSECTION
1 AT STA: 491+97 184.1 SQ YD

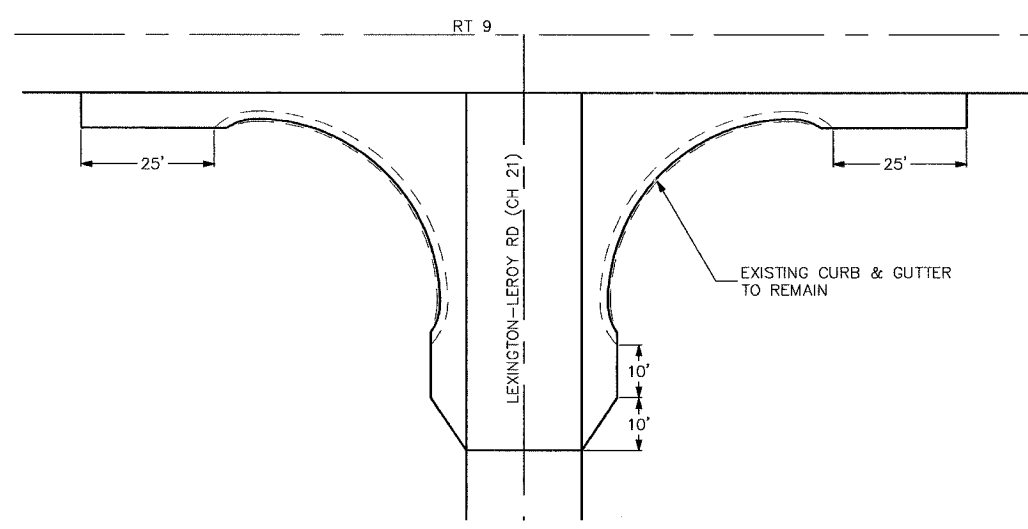

PRIVATE ENTRANCE
5 @ 64.1 SQ YDS EACH

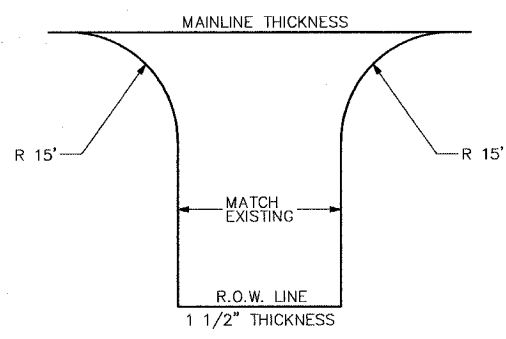

SPECIAL SIDE ROAD RETURNS
LEXINGTON-LEROY RD (CH 21) & 875N
LEXINGTON-LEROY RD (CH 21) & 1200N
202 SQ YDS EACH SIDE AT TWO LOCATIONS
808 SQ YDS TOTAL

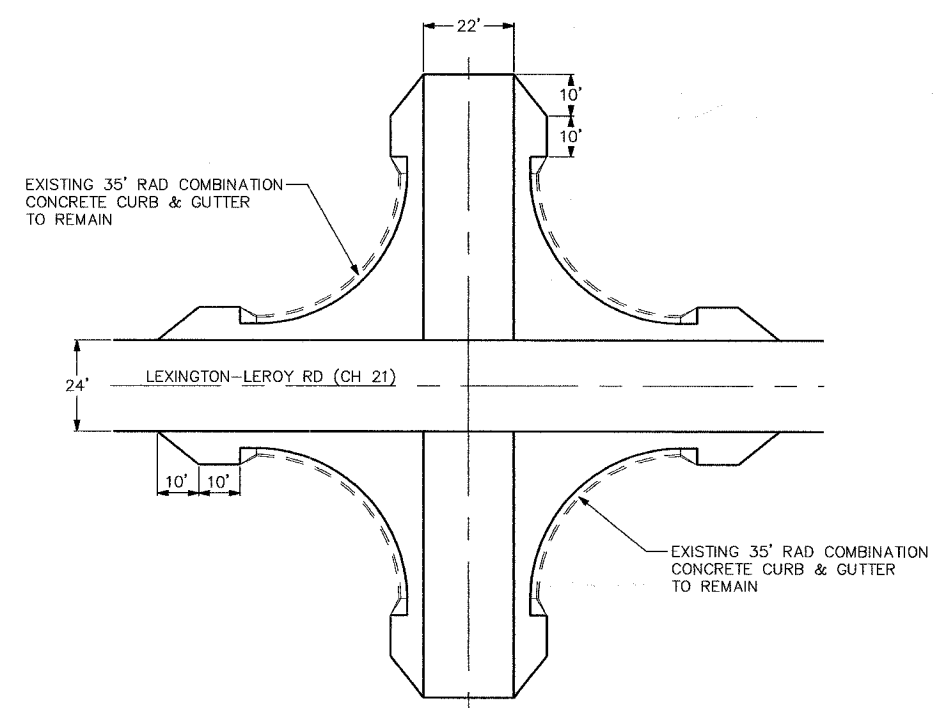

BITUMINOUS SURFACE REMOVAL-BUTT JOINT

- 1 @ STA: 215+10 122.2 SQ YD
- 1 @ STA: 357+95 (RR TRACKS) 122.2 SQ YD
- 1 @ STA: 358+01 (RR TRACKS) 122.2 SQ YD
- 1 @ STA: 491+97 (RT 9) 404.1 SQ YD

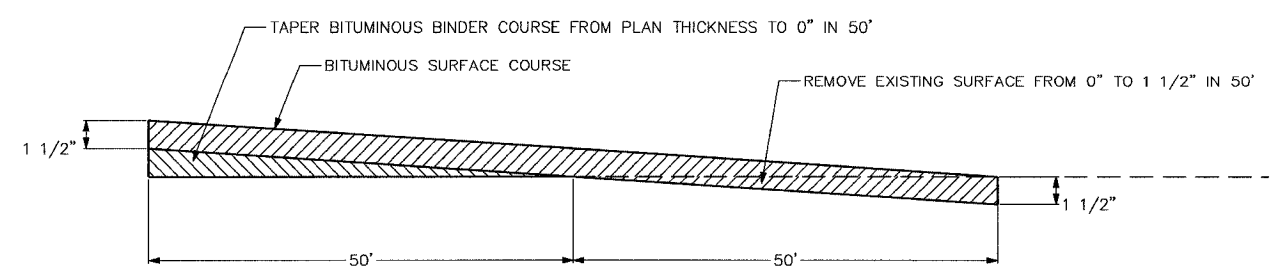

- NOTES:**
- ALL TEMPORARY AND PERMANENT PAVEMENT STRIPING WILL BE DONE BY OTHERS.
 - ALL FIELD ENTRANCES SHALL BE CONSTRUCTED WITH THE EXTENDABLE SCREED WIDENERS AND PAID FROM BITUMINOUS BINDER AND SURFACE COURSES.
 - ALL SPECIAL INTERSECTION RADII TO BE CONSTRUCTED AND PAID FROM BITUMINOUS BINDER AND SURFACE COURSES.
 - ALL SIDE ROAD RETURNS, SPECIAL SIDE ROAD RETURNS, PRIVATE ENTRANCES & MAILBOX TURNOUTS ARE TO BE CONSTRUCTED AND PAID FROM INCIDENTAL BITUMINOUS SURFACE COURSE.
 - AGGREGATE SHOULDERS SHALL BE PLACED ALONG ALL SIDE ROAD RETURN RADII AND PRIVATE ENTRANCE RADII AND ALSO SHALL BE PLACED ALONG AND BEHIND ALL FIELD ENTRANCES, GUARDRAIL RUNOUTS, UNDER GUARDRAIL AND MAILBOX TURNOUTS UNLESS SPECIFIED BY THE ENGINEER.