

ROUTE NO.	SECTION	COUNTY	TOTAL SHEETS	SHEET NO.
CH 31	*	MACON	162	46
FEDERAL DIST. NO.		ILLINOIS	PROJECT	
* 02-00175-00-PV				

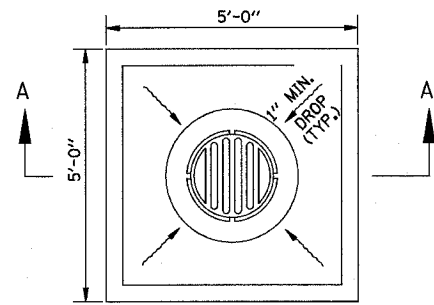

PLAN

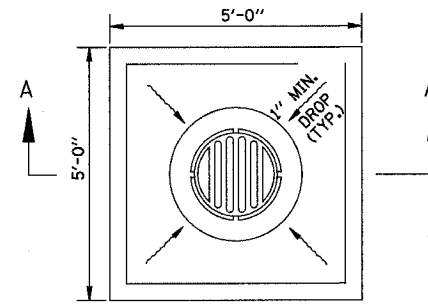

PLAN

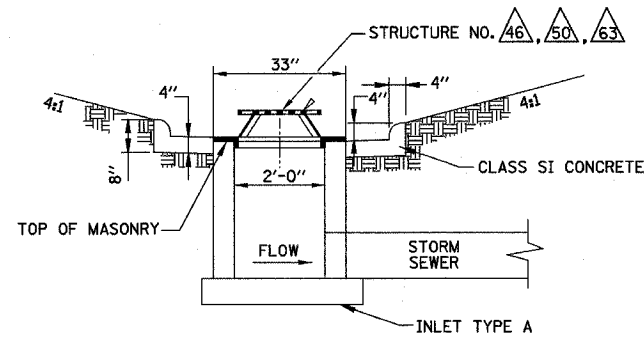

SECTION A-A
NOT TO SCALE

(SEE STRUCTURE NOTES FOR ELEVATIONS)

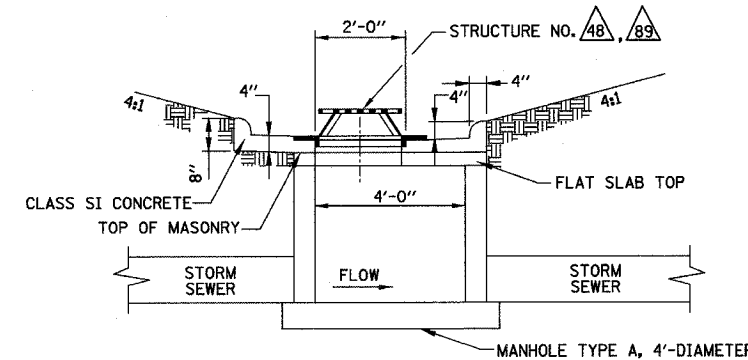

SECTION A-A
NOT TO SCALE

(SEE STRUCTURE NOTES FOR ELEVATIONS)

INLETS, TYPE A, WITH SPECIAL FRAME AND GRATE

MANHOLES, TYPE A, 4'-DIAMETER, WITH SPECIAL FRAME AND GRATE

NOTES

1. THE CONTRACTOR SHALL CONSTRUCT AN INLET TYPE A WITH SPECIAL FRAME AND GRATE AND CONCRETE APRON AS DETAILED ABOVE AT THE LOCATIONS INDICATED IN THE PLANS IN ACCORDANCE WITH SECTION 602 OF THE STANDARD SPECIFICATIONS FOR ROAD AND BRIDGE CONSTRUCTION (SSRB) ADOPTED JANUARY 1, 2002.
2. THE CONCRETE FOR THE CONCRETE APRON SHALL MEET THE REQUIREMENTS OF SECTION 1020 OF THE SSRB.
3. THE FRAME AND GRATE SHALL BE A DITCH GRATE, STOOL TYPE, NEENAH R-4341-A OR APPROVED EQUIVALENT MEETING THE REQUIREMENTS OF SECTION 604 OF THE SSRB.
4. THIS WORK SHALL BE PAID FOR AT THE CONTRACT UNIT PRICE EACH FOR INLETS, TYPE A, WITH SPECIAL FRAME AND GRATE AND NO ADDITIONAL COMPENSATION WILL BE ALLOWED.

NOTES

1. THE CONTRACTOR SHALL CONSTRUCT A MANHOLE TYPE A WITH SPECIAL FRAME AND GRATE AND CONCRETE APRON AS DETAILED ABOVE AT THE LOCATIONS INDICATED IN THE PLANS IN ACCORDANCE WITH SECTION 602 OF THE SSRB.
2. THE FLAT SLAB TOP SHALL BE CONSTRUCTED IN ACCORDANCE WITH THE HIGHWAY STANDARD 602601.
3. THE CONCRETE FOR THE CONCRETE APRON SHALL MEET THE REQUIREMENTS OF SECTION 1020 OF THE SSRB.
4. THE FRAME AND GRATE SHALL BE A DITCH GRATE, STOOL TYPE, NEENAH R-4341-A OR APPROVED EQUIVALENT MEETING THE REQUIREMENTS OF SECTION 604 OF THE SSRB.
5. THIS WORK SHALL BE PAID FOR AT THE CONTRACT UNIT PRICE EACH FOR MANHOLES, TYPE A, 4'-DIAMETER, WITH SPECIAL FRAME AND GRATE AND NO ADDITIONAL COMPENSATION WILL BE ALLOWED.

REVISIONS			MISCELLANEOUS DETAILS	
NO.	DATE	INITIALS		
1			<p>TURPIN ROAD CONNECTOR (CH 31) MACON COUNTY, ILLINOIS</p> <p>HOMER L. CHASTAIN & ASSOCIATES, LLP CONSULTING ENGINEERS 184-00197</p> <p>DECATUR (317) 422-8544 CHICAGO (773) 714-0050</p>	
2				
3				
4				
5				
6				
7				
8				
9				
10				
			DRAWN BY LBM	DATE 04/05
			CHECKED BY CAS	DATE 04/05
			BOOK NUMBER 471	
			PROJECT No. 4805	
			SHEET No.	