

steffennk
 3/31/2005
 c:\projects\94944d\01302pa.dgn
 DET

REF.	SECTION	COUNTY	TOTAL SHEETS	SHEET NO.
332	(18,19,20) RS-2	CRAWFORD	21	6
FED. ROAD DIST. NO. 7	ILLINOIS	FED. AID PROJECT NO.		

CONTRACT NO. 94944



NOTES:

1. MILLING SHALL BE DONE TO ATTAIN A 3/16" SLOPE IN CROWN SECTIONS
2. EXISTING S.E. AND S.E. TRANSITIONS SHALL BE MAINTAINED UNLESS OTHERWISE SHOWN ON THE PLANS.
3. MILLING TO THE BOTTOM OF WHEEL RUTS SHALL NOT BE NECESSARY UNLESS REQUIRED TO OBTAIN SLOPE OR THE DESIGN DEPTH AT CENTERLINE.
4. THE AVERAGE DEPTH OF MILLING IS ESTIMATED TO BE 1/2" BUT MAY VARY IN ISOLATED LOCATIONS.

BITUMINOUS SURFACE REMOVAL (VARIABLE DEPTH) DETAIL

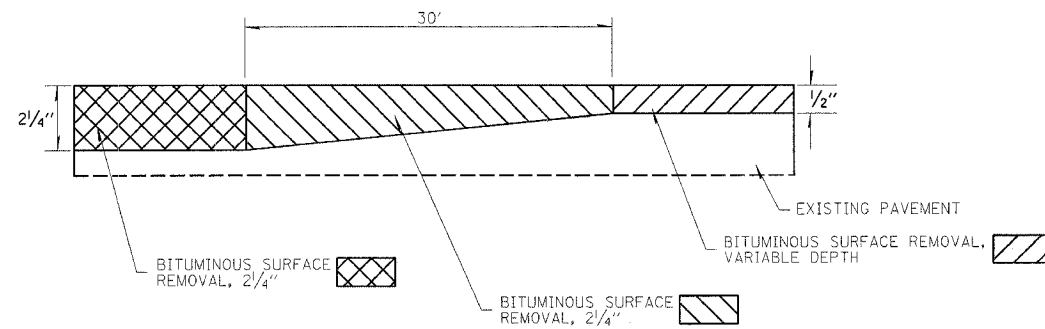

MILLING TRANSITION

STA 612+29 TO STA 612+59
 STA 618+00 TO STA 618+30
 STA 1000+16 TO STA 1000+46

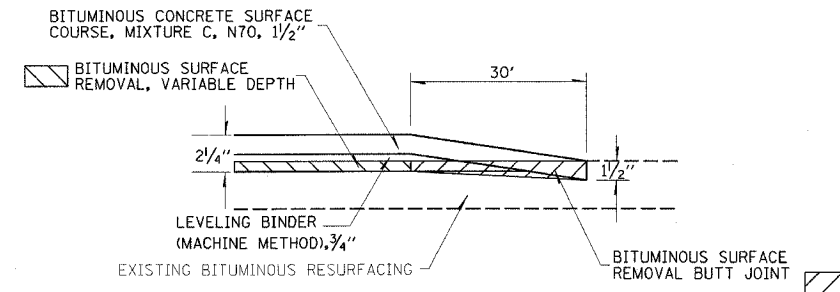

BUTT JOINT DETAIL

STA 440+50 TO STA 440+80
 STA 490+47 TO STA 490+77
 STA 491+99 TO STA 492+29

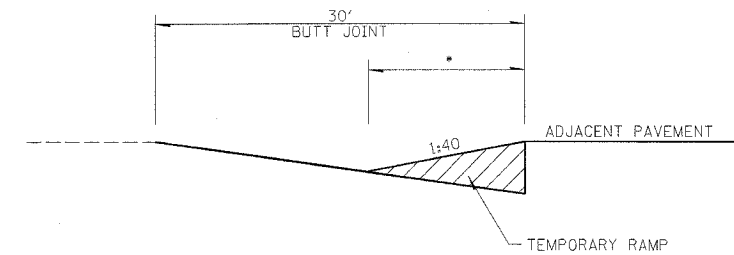

TEMPORARY RAMP DETAIL

- 1 1/2 - 5' RAMP
- 2 1/4 - 7.5' RAMP

REVISIONS	
NAME	DATE

ILLINOIS DEPARTMENT OF TRANSPORTATION

DETAILS

SCALE: VERT.
 HORIZ.
 DATE

DRAWN BY
 CHECKED BY